



website <http://www.lgservice.com>  
e-mail <http://www.lgservice.com/techsup.html>

LG

# LG

## Universal System

### Air Conditioner

# *SERVICE MANUAL*

#### CAUTION

- BEFORE SERVICING THE UNIT, READ THE SAFETY PRECAUTIONS IN THIS MANUAL.
- ONLY FOR AUTHORIZED SERVICE PERSONNEL.

# TABLE OF CONTENTS

## ***Table of contents***

## ***Page***

1. Models List .....	3
2. Model Number Nomenclature .....	4
3. Safety Precautions .....	5
4. Feature & Benefits .....	9
5. List of Functions .....	13
6. Function of Remote Control .....	16
7. Specifications .....	21
8. Dimensional Drawings .....	33
9. Wiring Diagrams.....	43
10. Refrigerant Cycle Diagrams .....	52
11. Electrical Data .....	54
12. Operation Range.....	55
13. External Static Pressure & Air flow .....	56
14. Installation .....	60
15. Electronic Control Device .....	78
16. Schematic Diagram.....	81
17. Exploded View and Replacement Parts List .....	85

# Models List

## 1.1 Cooling Only

Nominal Capacity		Indoor Units		Outdoor Units	Power Supply
kW	Btu/h	Type	Model Name	Model Name	Ø,V,Hz
5.3	18K	Ceiling Cassette	ATNC186ELAA	AUUC186A/AB	1Ø, 220-240V, 50Hz
		Ceiling Cassette	ATNC186ELCA		
		Ceiling Concealed Duct	ABNC186HLAA		
		Ceiling & Floor	AVNC186BLAA		
7.0	24K	Ceiling Cassette	ATNC246FLAA	AUUC246A/AB	
		Ceiling Cassette	ATNC246FLCA		
		Ceiling Concealed Duct	ABNC246HLAA		
		Ceiling & Floor	AVNC246BLAA		
8.8	30K	Ceiling Cassette	ATNC306FLAA	AUUC306A/AB	
		Ceiling Cassette	ATNC306FLCA		
		Ceiling Concealed Duct	ABNC306GLAA		
		Ceiling & Floor	AVNC306BLAA		
10.6	36K	Ceiling Cassette	ATNC368DLAA	AUUC368A/AB	3Ø, 380-415V, 50Hz
		Ceiling Cassette	ATNC368DLCA		
		Ceiling Concealed Duct	ABNC368GLAA		
14.1	48K	Ceiling Cassette	ATNC488DLAA	AUUC488A/AB	
		Ceiling Cassette	ATNC488DLCA		
		Ceiling Concealed Duct	ABNC488ELAA		
17.6	60K	Ceiling Cassette	ATNC608DLAA	AUUC608A/AB	
		Ceiling Cassette	ATNC608DLCA		
		Ceiling Concealed Duct	ABNC608ELAA		

## 1.2 Heat Pump

Nominal Capacity		Indoor Units		Outdoor Units	Power Supply
kW	Btu/h	Type	Model Name	Model Name	Ø,V,Hz
5.3	18k	Ceiling Cassette	ATNH186ELAA	AUUH186A/AB	1Ø, 220-240V, 50Hz
		Ceiling Cassette	ATNH186ELCA		
		Ceiling Concealed Duct	ABNH186HLAA		
		Ceiling & Floor	AVNH186BLAA		
7.0	24k	Ceiling Cassette	ATNH246FLAA	AUUH246A/AB	
		Ceiling Cassette	ATNH246FLCA		
		Ceiling Concealed Duct	ABNH246HLAA		
		Ceiling & Floor	AVNH246BLAA		
8.8	30k	Ceiling Cassette	ATNH306FLAA	AUUH306A/AB	
		Ceiling Cassette	ATNH306FLCA		
		Ceiling Concealed Duct	ABNH306GLAA		
		Ceiling & Floor	AVNH306BLAA		
10.6	36k	Ceiling Cassette	ATNH368DLAA	AUUH368A/AB	3Ø, 380-415V, 50Hz
		Ceiling Cassette	ATNH368DLCA		
		Ceiling Concealed Duct	ABNH368GLAA		
14.1	48k	Ceiling Cassette	ATNH488DLAA	AUUH488A/AB	
		Ceiling Cassette	ATNH488DLCA		
		Ceiling Concealed Duct	ABNH488ELAA		
17.6	60K	Ceiling Cassette	ATNH608DLAA	AUUH608A/AB	
		Ceiling Cassette	ATNH608DLCA		
		Ceiling Concealed Duct	ABNH608ELAA		

# Model Number Nomenclature

## 2.1 Indoor Units

**A T N H 1 8 6 E L A A**

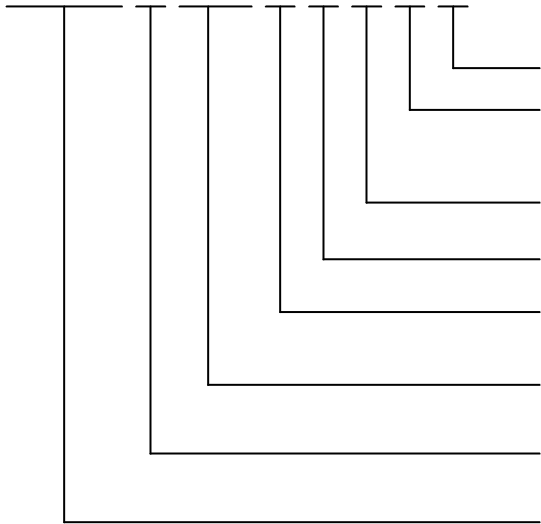

Serial Number  
 Functions  
 A : Basic C : Plasma Air Purifier(Optional)  
 Look : Basic  
 Chassis Name  
 Electrical Ratings  
 6:1Ø,220-240V,50Hz                      8:3 Ø,380-415V,50Hz  
 Nominal Cooling Capacity in Btu/h  
 Ex) 18 -> 18,000 Btu/h    48 -> 48,000 Btu/h  
 Model Type  
 C: Cooling Only                      H: Heat Pump  
**R410A Universal Indoor Unit**  
 ATN : Universal Ceiling Cassette Type Indoor Unit  
 ABN : Universal Ceiling Concealed Duct Type Indoor Unit  
 AVN : Universal Ceiling & Floor Type Indoor Unit

## 2.2 Decoration panel (For Ceiling Cassette Models)

**P T - H E A**

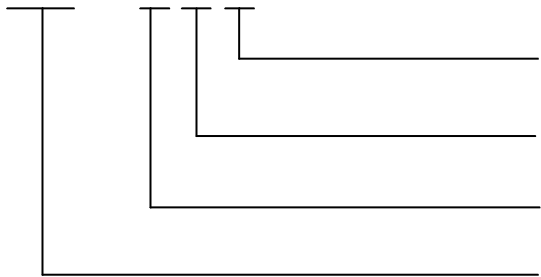

Functions  
 A: Basic C:For Indoor Unit with Plasma Air Purifier.(Optional)  
 Indoor Unit Chassis  
 D: D Chassis                      E: E Chassis                      F: F Chassis  
 Model Type  
 C : Cooling Only                      H : Heat Pump  
**Decoration Panel of Ceiling Cassette Type Indoor Unit**

## 2.3 Outdoor Units

**A U U H 1 8 6 A B**

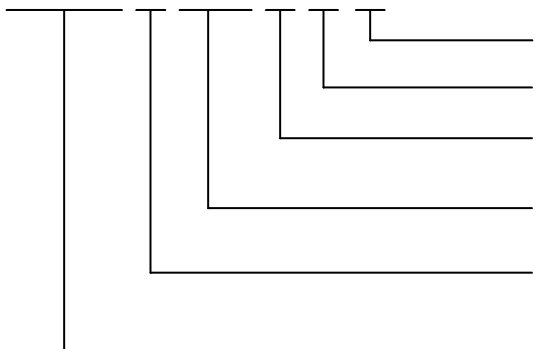

Low Ambient(Optional)  
 Serial Number  
 Electric Standard (Phase, Volts, Freq)  
 6:1 Ø,220-240V,50Hz                      8:3 Ø,380-415V,50Hz  
 Nominal Cooling Capacity in Btu/h  
 Model Type  
 C : Cooling Only                      H : Heat Pump  
**R410A Universal Outdoor Unit**

# Safety Precautions

To prevent injury to the user or other people and property damage, the following instructions must be followed.

■ Incorrect operation due to ignoring instruction will cause harm or damage. The seriousness is classified by the following indications.

**⚠ WARNING** This symbol indicates the possibility of death or serious injury.

**⚠ CAUTION** This symbol indicates the possibility of injury or damage to properties only.

■ Meanings of symbols used in this manual are as shown below.

	<b>Be sure not to do.</b>
	<b>Be sure to follow the instruction.</b>

## ⚠ WARNING

### ■ Installation

**Do not use a defective or under-rated circuit breaker. Use this appliance on a dedicated circuit.**

- There is risk of fire or electric shock.

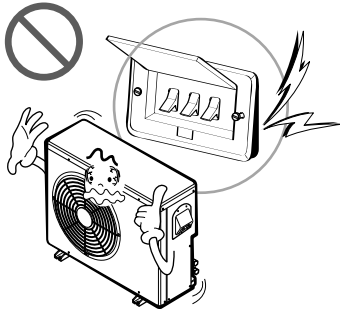

**Always ground the product.**

- There is risk of fire or electric shock.

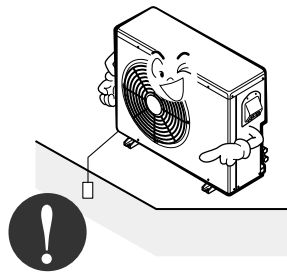

**Install the panel and the cover of control box securely.**

- There is risk of fire or electric shock.

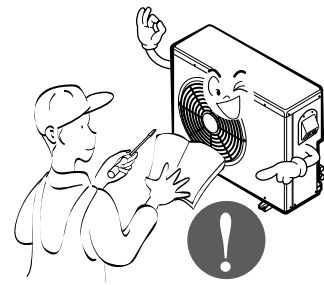

**Always install a dedicated circuit and breaker.**

- Improper wiring or installation may cause fire or electric shock

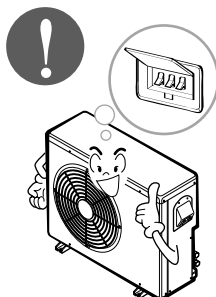

**Use the correctly rated breaker or fuse.**

- There is risk of fire or electric shock.

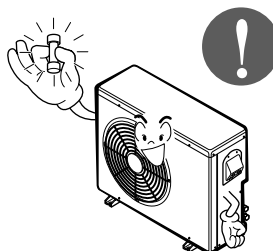

**Do not modify or extend the power cable.**

- There is risk of fire or electric shock.

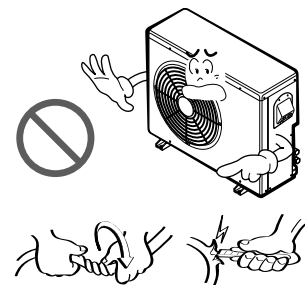

## Safety Precautions

**Do not install, remove, or re-install the unit by yourself (customer).**

- There is risk of fire, electric shock, explosion, or injury.



**Be cautious when unpacking and installing the product.**

- Sharp edges could cause injury. Be especially careful of the case edges and the fins on the condenser and evaporator.

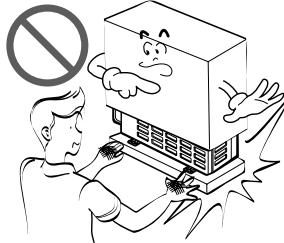

**For installation, always contact the dealer or an Authorized Service Center.**

- There is risk of fire, electric shock, explosion, or injury.

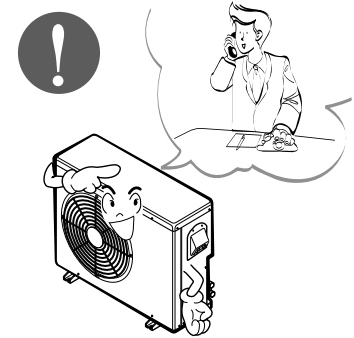

**Do not install the product on a defective installation stand.**

- It may cause injury, accident, or damage to the product.

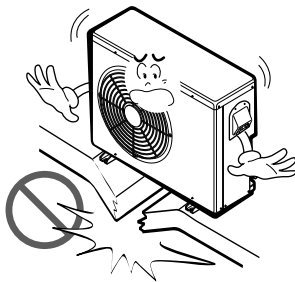

**Be sure the installation area does not deteriorate with age.**

- If the base collapses, the air conditioner could fall with it, causing property damage, product failure, and personal injury.

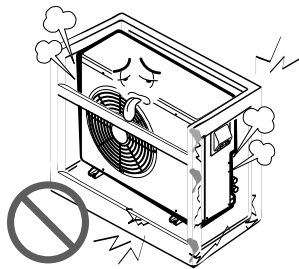

**Do not let the air conditioner run for a long time when the humidity is very high and a door or a window is left open.**

- Moisture may condense and wet or damage furniture.



## Operational

**Do not touch (operate) the product with wet hands.**

- There is risk of fire or electrical shock.



**Do not place a heater or other appliances near the power cable.**

- There is risk of fire or electric shock.

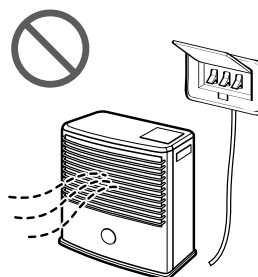

**Do not let electric parts of the product get wet.**

- There is risk of fire, failure of the product, or electric shock.

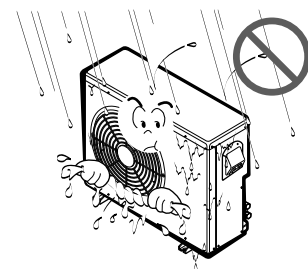

**Do not store or use flammable gas or combustibles near the product.**

- There is risk of fire or failure of product.

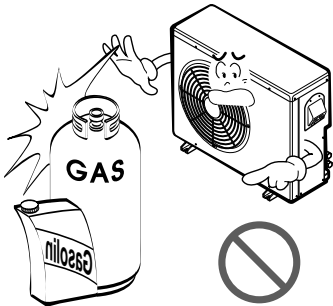

**If strange sounds, or small or smoke comes from product. Turn the breaker off or disconnect the power supply cable.**

- There is risk of electric shock or fire.



**Do not open the inlet grill of the product during operation. (Do not touch the electrostatic filter, if the unit is so equipped.)**

- There is risk of physical injury, electric shock, or product failure.

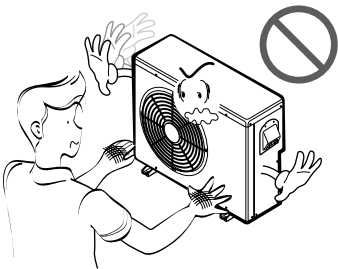

**Be cautious that water could not enter the product.**

- There is risk of fire, electric shock, or product damage.

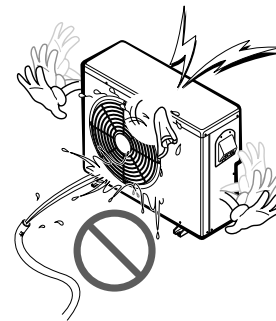

**CAUTION**

**Installation**

**Always check for gas (refrigerant) leakage after installation or repair of product.**

- Low refrigerant levels may cause failure of product.

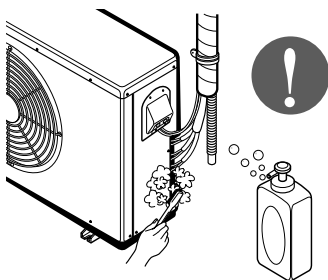

**Install the drain hose to ensure that water is drained away properly.**

- A bad connection may cause water leakage.

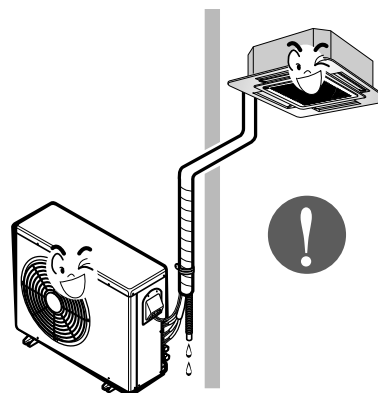

## Safety Precautions

### Keep level even when installing the product.

- To avoid vibration or water leakage.

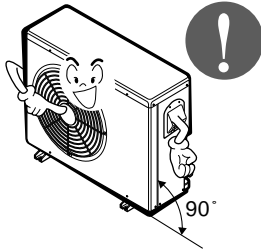

### Use two or more people to lift and transport the product.

- Avoid personal injury.



## Operational

### Use a soft cloth to clean. Do not use harsh detergents, solvents, etc.

- There is risk of fire, electric shock, or damage to the plastic parts of the product.



### Do not touch the metal parts of the product when removing the air filter. They are very sharp!

- There is risk of personal injury.

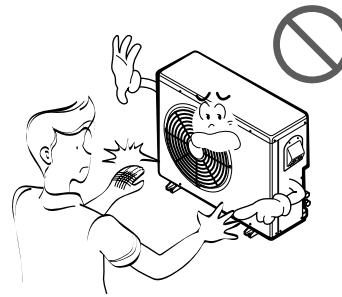

### Do not step on or put anything on the product. (outdoor units)

- There is risk of personal injury and failure of product.



### Do not insert hands or other objects through the air inlet or outlet while the product is operated.

- There are sharp and moving parts that could cause personal injury.

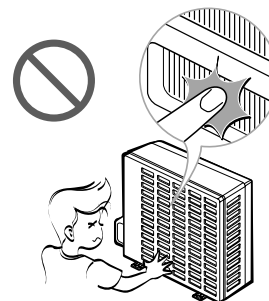



# Features & Benefits

## Environment Friendly Refrigerant :

- LG Ceiling Cassette Air Conditioners uses environment friendly refrigerant, which don't do any harm to the environment.

## Jet Cool :

-In this mode, quick and fast cooling is done. Cold and high velocity air is supplied to the room till the indoor temperature reaches 18°C. The unit will continue to run in jet cool mode till the Indoor temperature reaches 18°C.

## Energy Saving Gold Fin :

- Heat Exchanger fins are coated with anticorrosive & hydrophilic layers. It prevents the corrosion of heat exchanger. Fins remain as new even after long time of operation and maintains efficiency of heat exchanger. It also saves power & maintenance Cost.

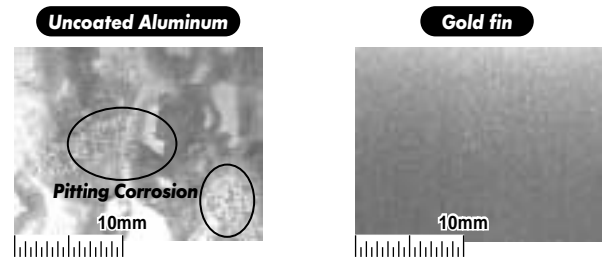

**Salt Spray Test Result : After 360 hours**  
[ Test Standard: ASTM B-117, KS D 9502 ]

## Plasma Air Purifier :

- It removes not only microscopic contaminants & dust, but also house mites, pollen, and pet fur to help preventing allergic diseases like asthma. It provides odor free, dust free and allergy free air.

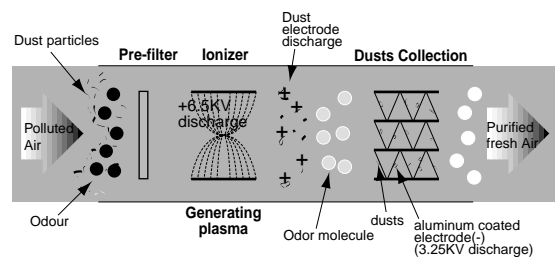

## Group Control :

- It enables to control as much as 16 units with the help of one wired remote controller. All the units will follow same setting of temperature & other sub functions.

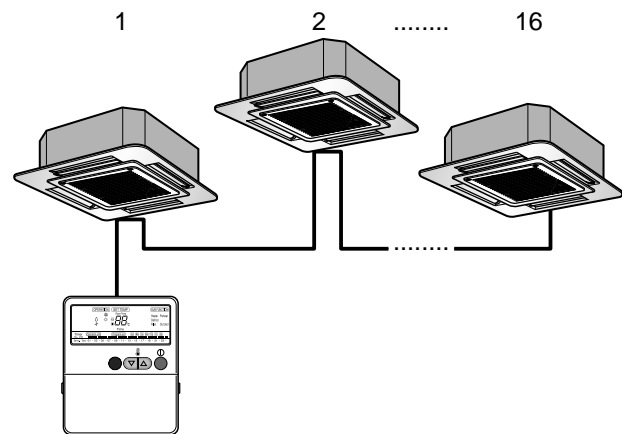

## Central Control :

- It enables to control 16 x 8 = 128 units with the help of 8 controllers. All units can be put on and off from one Central Room. For Setting Temperature, Fan Speed and other sub functions, access the respective LCD wired remote controller of each unit.

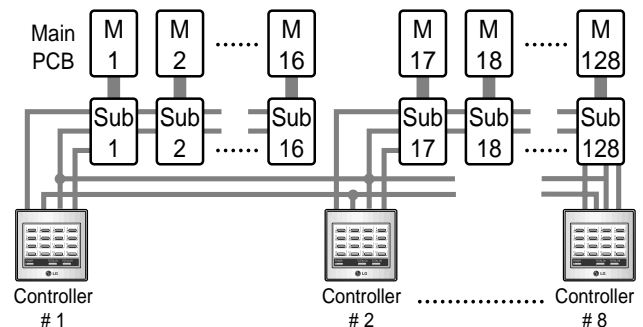

### Swirl Swing(For Ceiling Cassette):

- It is the function for comfort cooling/heating operation.
- The diagonal two louvers are opened the more larger than the other louvers. After one minute, it is opposite.

Comparison of Floor Temp. Distribution(20°C)

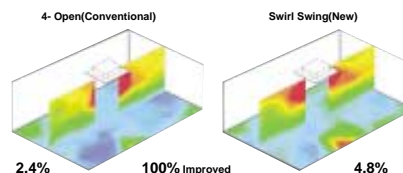

Comparison of Air Flow Types

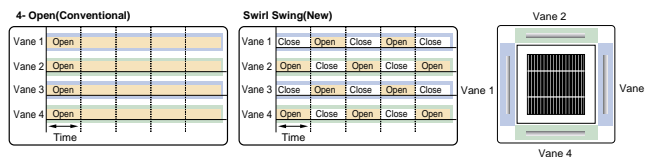

### Space Control (For Ceiling Cassette):

Vaness angle can be controlled by pair, considering its installation environment.

- For example direct drafts can be annoying, leading to discomfort and reduced productivity vane control helps to eliminate this problem.
- Easily controlled by wired remote control.
- Air Flow can be controlled easily regarding any space environment.

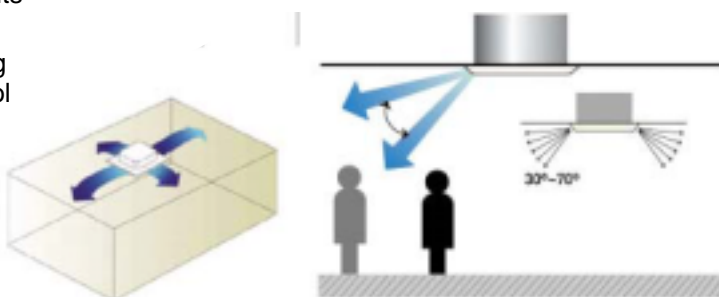

### Auto Restart Operation :

- Whenever there is electricity failure to the unit, and after resumption of the power, unit will start in the same mode prior to the power failure. Memorized condition are on / off condition, operating mode (cooling/heating), set temperature and fan speed. The unit will memorize the above conditions and start with same memorized condition.

### Two Thermistor Control :

- There may be a significant difference between the temperature taken at the installed product and indoor temperature. Two thermistor control provides option to control temperature by referring any of the two temperatures. With the help of the slide switch at the back of the LCD wired remote controller, selection of the desired thermistor for controlling the unit can be done. One thermistor is in the Indoor unit & the other one is in the LCD wired remote.

### Auto Changeover :

- While starting the unit it first senses the indoor temperature & starts the unit either in the cooling or in heating mode, depending upon the indoor temperature. Range of operation is Setting Temp.± 2°C.

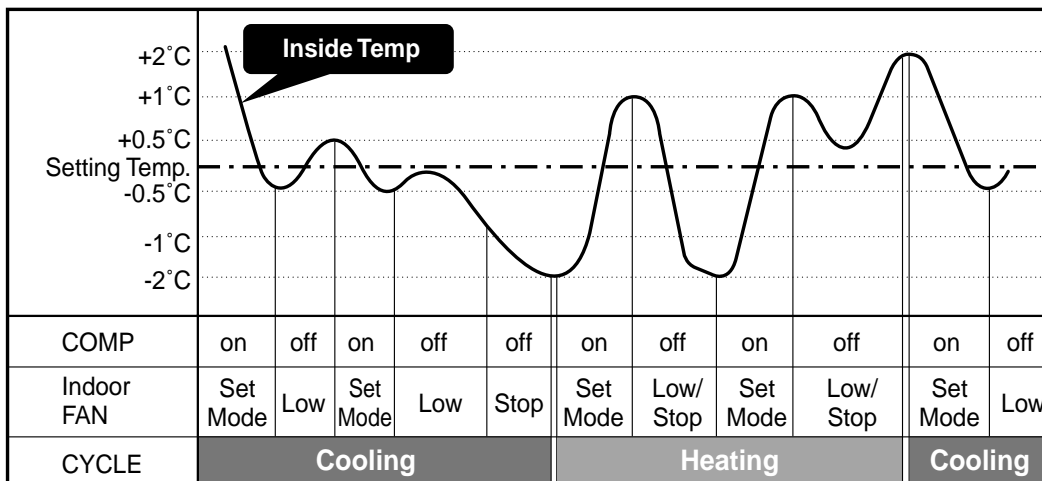

### Defrost / Deicing :

- In the heating mode, it prevents the ice formation on the outdoor unit. The heating cycle is reversed to the cooling cycle to defrost the evaporator pipe of the outdoor unit. While defrost cycle, the compressor is on and indoor fan, outdoor fan and 4-way valve are off.

### Low Ambient Control:

- If the outdoor temperature drops below certain temperature, liquid back to the compressor is prevented by reducing outdoor fan speed. It can prevent frosting of evaporator and keep cooling operation on.

### High Ceiling Operation(For Ceiling Cassette)

- According to the height of ceiling installation, it provides variability of indoor fan motor rpm. If the height of installation is low then you can adjust low rpm of indoor fan motor. On the other hand if the height of the installation is high you can adjust high rpm of indoor fan motor. Selection of speed can be done by slide switch at the back of the LCD wired remote.

ex:

Selection	Height	RPM
Lower	2.4m	700/600/500
Standard	2.7m	750/650/550
Higher	3.0m	800/700/600

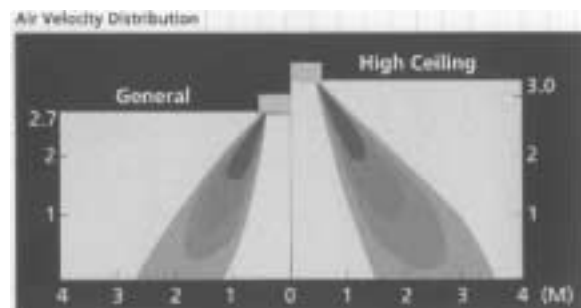
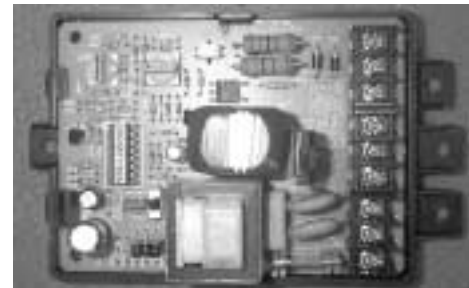

### Water Drain Pump :

- In some of the places natural drainage is not possible. For such places drain pump is very useful. It removes condensed water from the unit.

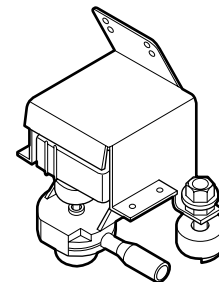

### Time Delay Safety Function :

- It delays restarting of the compressor by three minutes thereby preventing damage to the compressor.

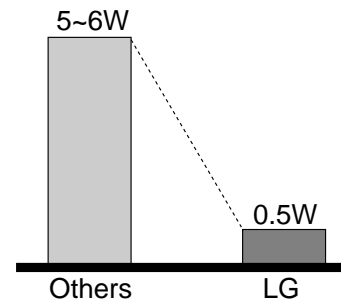

### Zero Standby Power:

- Due to SMPS (Switching Modulation Power Supply) technology, there is almost zero power consumption in the standby mode.

### Child Lock Function:

-It prevents the children or others from tampering the control buttons. Unit can be controlled by the wireless remote controller. This can be easily set by pressing timer key & Min key simultaneously. After child lock is set, pressing any key will display CL on the LCD for 3 seconds and all the keys will be ineffective.

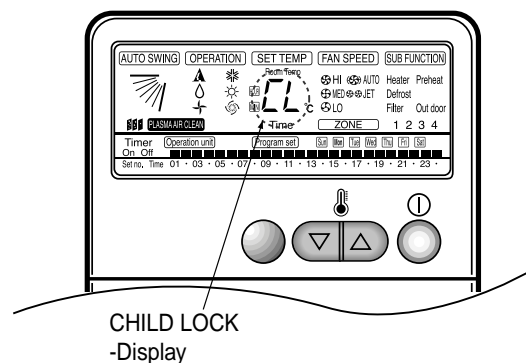

### Zone Control:

- It controls the temperature of each zone. Opening or closing of the damper is controlled by sensing the temperature of each zone. In the cooling mode, if the temperature of a particular zone is lower than set temperature then the damper is closed. On the other hand if the temperature of a particular zone is higher than the set temperature damper is open to provide cooling to the zone & vice versa in the heating mode.

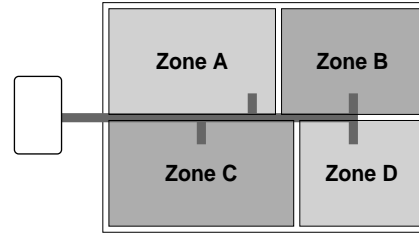

### Tele Control :

- It provides you ease of control. Air conditioner can be switched on/off by the telephone. It saves time & energy.



In Advance by Telephone Before Coming Home...

In case of Going out Without Turning off the Air Conditioner...

### E.S.P. Control:

- Generally, when External Static Pressure increases air volume decreases. But by controlling the phase of motor while installing the product, E.S.P. is controlled from 8~10mm Aq, linearly. E.S.P. control provides required constant air volume irrespective of ESP change. Desired ESP can also be set through LCD wired remote. Setting of the desired ESP gives required combination of ESP and air-flow.

E.S.P Control

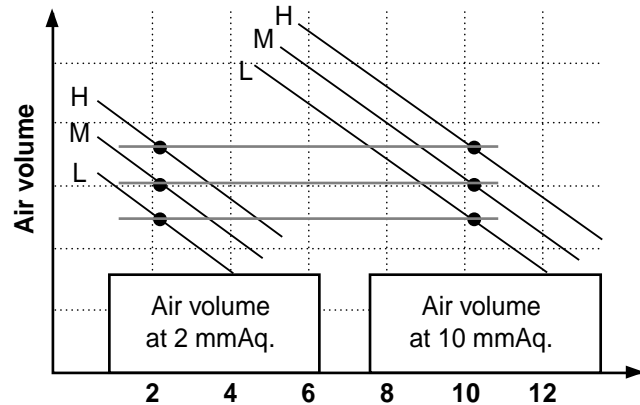

### Electric Heater:

- Electric Heater can be used to provide heat in addition to cycle heat. It also provide & quick heating. It can also work as a stand alone heater with only fan operation.

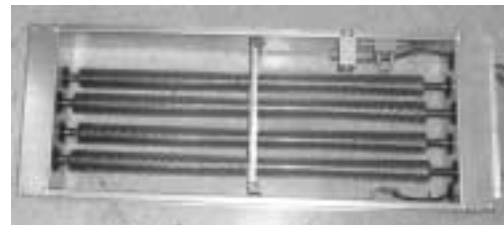

### Self Diagnosis Function:

- This function provides diagnosis of the unit. An error code will be displayed on the LCD wired remote controller & diagnosis can be done as per the code indication. The same is also printed on key cover of the LCD wired remote controller.

# List of Functions

## 1 Ceiling Cassette

Features	Model	Ceiling Cassette					
		ATNC-EL	ATNC-FL	ATNC-DL	ATNH-EL	ATNH-FL	ATNH-DL
Air Discharge Outlet		4	4	4	4	4	4
Airflow Direction control (left & right)		-	-	-	-	-	-
Airflow Direction control (up & down)		Auto	Auto	Auto	Auto	Auto	Auto
Airflow Steps(Fan / Cool /Heat)		3/4/-	3/4/-	3/4/-	3/4/3	3/4/3	3/4/3
Auto Changeover		-	-	-	o	o	o
Auto Operation		o	o	o	o	o	o
Auto Restart Operation		o	o	o	o	o	o
Auto Swing		o	o	o	o	o	o
Central Control		Accessory	Accessory	Accessory	Accessory	Accessory	Accessory
CHAOS Wind (Auto wind)		-	-	-	-	-	-
Child Lock Function		o	o	o	o	o	o
Cooling & Fan Operation		o	o	o	o	o	o
Cooling, heating & Fan Operation		-	-	-	o	o	o
Defrost / Deicing		-	-	-	o	o	o
Deodorizing Filter		-	-	-	-	-	-
Drain Pump		o	o	o	o	o	o
E.S.P. Control		-	-	-	-	-	-
Electric Heater		-	-	-	-	-	-
Energy Saving Gold Fin		Optional	Optional	Optional	Optional	Optional	Optional
Environment Friendly Refrigerant		o	o	o	o	o	o
Fire Alarm Function		-	-	-	-	-	-
Forced Operation		o	o	o	o	o	o
Group Control		o	o	o	o	o	o
High Ceiling Operation		o	o	o	o	o	o
Hot Start		-	-	-	o	o	o
Jet Cool		o	o	o	o	o	o
Low Ambient Control		Optional	Optional	Optional	Optional	Optional	Optional
Plasma Air Purifier		Optional	Optional	Optional	Optional	Optional	Optional
Prefilter(Washable / Anti-fungus)		o	o	o	o	o	o
Restart Delay (3-minutes)		o	o	o	o	o	o
Self Diagnosis		o	o	o	o	o	o
Sleep Mode		o	o	o	o	o	o
Soft Dry Operation		o	o	o	o	o	o
Swirl Swing		o	o	o	o	o	o
Tele Control		-	-	-	-	-	-
Temperature Control		o	o	o	o	o	o
Test Function		o	o	o	o	o	o
Time Delay Safety function		o	o	o	o	o	o
Timer (weekly)		o	o	o	o	o	o
Two Thermistor Control		o	o	o	o	o	o
Space Control		o	o	o	o	o	o
Wired LCD Remote Controller		o	o	o	o	o	o
Wireless Remote Controller		o	o	o	o	o	o
Zero Standby Power		o	o	o	o	o	o
Zone Control		-	-	-	-	-	-

Notes :

O : Basic

Optional : Factory-Installed

Accessory : Field-Installed

- : Not available on this system

## 2 Ceiling Concealed Duct

Features	Ceiling Concealed Duct					
	ABNC-HL	ABNC-GL	ABNC-EL	ABNH-HL	ABNH-GL	ABNH-EL
Discharge Outlet	-	-	-	-	-	-
Airflow Direction control (left & right)	-	-	-	-	-	-
Airflow Direction control (up & down)	-	-	-	-	-	-
Airflow Steps(Fan / Cool /Heat)	3/3/-	3/3/-	3/3/-	3/3/3	3/3/3	3/3/3
Auto Changeover	-	-	-	o	o	o
Auto Operation	o	o	o	o	o	o
Auto Restart Operation	o	o	o	o	o	o
Auto Swing	-	-	-	-	-	-
Central Control	Accessory	Accessory	Accessory	Accessory	Accessory	Accessory
CHAOS Wind (Auto wind)	-	-	-	-	-	-
Child Lock Function	o	o	o	o	o	o
Cooling & Fan Operation	o	o	o	o	o	o
Cooling, heating & Fan Operation	-	-	-	o	o	o
Defrost / Deicing	-	-	-	o	o	o
Deodorizing Filter	-	-	-	-	-	-
Drain Pump	Accessory	Accessory	Accessory	Accessory	Accessory	Accessory
E.S.P. Control	o	o	-	o	o	-
Electric Heater	-	-	-	Accessory	Accessory	Accessory
Energy Saving Gold Fin	Optional	Optional	Optional	Optional	Optional	Optional
Environment Friendly Refrigerant	o	o	o	o	o	o
Fire Alarm Function	-	-	-	-	-	-
Forced Operation	o	o	o	o	o	o
Group Control	o	o	o	o	o	o
High Ceiling Operation	-	-	-	-	-	-
Hot Start	-	-	-	o	o	o
Jet Cool	-	-	-	-	-	-
Low Ambient Control	Optional	Optional	Optional	Optional	Optional	Optional
Plasma Air Purifier	Accessory	Accessory	Accessory	Accessory	Accessory	Accessory
Prefilter(Washable / Anti-fungus)	o	o	o	o	o	o
Restart Delay (3-minutes)	o	o	o	o	o	o
Self Diagnosis	o	o	o	o	o	o
Sleep Mode	o	o	o	o	o	o
Soft Dry Operation	o	o	o	o	o	o
Swirl Swing	-	-	-	-	-	-
Tele Control	Accessory	Accessory	Accessory	Accessory	Accessory	Accessory
Temperature Control	o	o	o	o	o	o
Test Function	o	o	o	o	o	o
Time Delay Safety function	o	o	o	o	o	o
Timer (weekly)	o	o	o	o	o	o
Two Thermistor Control	o	o	o	o	o	o
Space Control	-	-	-	-	-	-
Wired LCD Remote Controller	o	o	o	o	o	o
Wireless Remote Controller	Accessory	Accessory	Accessory	Accessory	Accessory	Accessory
Zero Standby Power	o	o	o	o	o	o
Zone Control	Accessory	Accessory	Accessory	Accessory	Accessory	Accessory

Notes :

O : Basic

Optional : Factory-Installed

Accessory : Field-Installed

- : Not available on this system

### 3 Ceiling & Floor

Features	Model	Ceiling Concealed Duct	
		AVNC-BL	AVNH-BL
Discharge Outlet		1	2
Airflow Direction control (left & right)		Manual	Manual
Airflow Direction control (up & down)		Auto	Auto
Airflow Steps(Fan / Cool /Heat)		3/3/-	3/3/3
Auto Changeover		-	o
Auto Operation		o	o
Auto Restart Operation		o	o
Auto Swing		o	o
Central Control		Accessory	Accessory
CHAOS Wind (Auto wind)		o	o
Child Lock Function		-	-
Cooling & Fan Operation		o	o
Cooling, heating & Fan Operation		-	o
Defrost / Deicing		-	o
Deodorizing Filter		-	-
Drain Pump		-	-
E.S.P. Control		-	-
Electric Heater		-	-
Energy Saving Gold Fin		Optional	Optional
Environment Friendly Refrigerant		o	o
Fire Alarm Function		-	-
Forced Operation		o	o
Group Control		-	-
High Ceiling Operation		-	-
Hot Start		-	o
Jet Cool		-	-
Low Ambient Control		Optional	Optional
Plasma Air Purifier		-	-
Prefilter(Washable / Anti-fungus)		o	o
Restart Delay (3-minutes)		o	o
Self Diagnosis		o	o
Sleep Mode		o	o
Soft Dry Operation		o	o
Swirl Swing		-	-
Tele Control		-	-
Temperature Control		o	o
Test Function		o	o
Time Delay Safety function		o	o
Timer (weekly)		-	-
Two Thermistor Control		-	-
Space Control		-	-
Wired LCD Remote Controller		-	-
Wireless Remote Controller		o (LCD)	o (LCD)
Zero Standby Power		-	-
Zone Control		-	-

Notes :

O : Basic

Optional : Factory-Installed

Accessory : Field-Installed

- : Not available on this system

# Function of Remote Control

## 1. Wireless LCD Remote Control(Ceiling & Floor models)

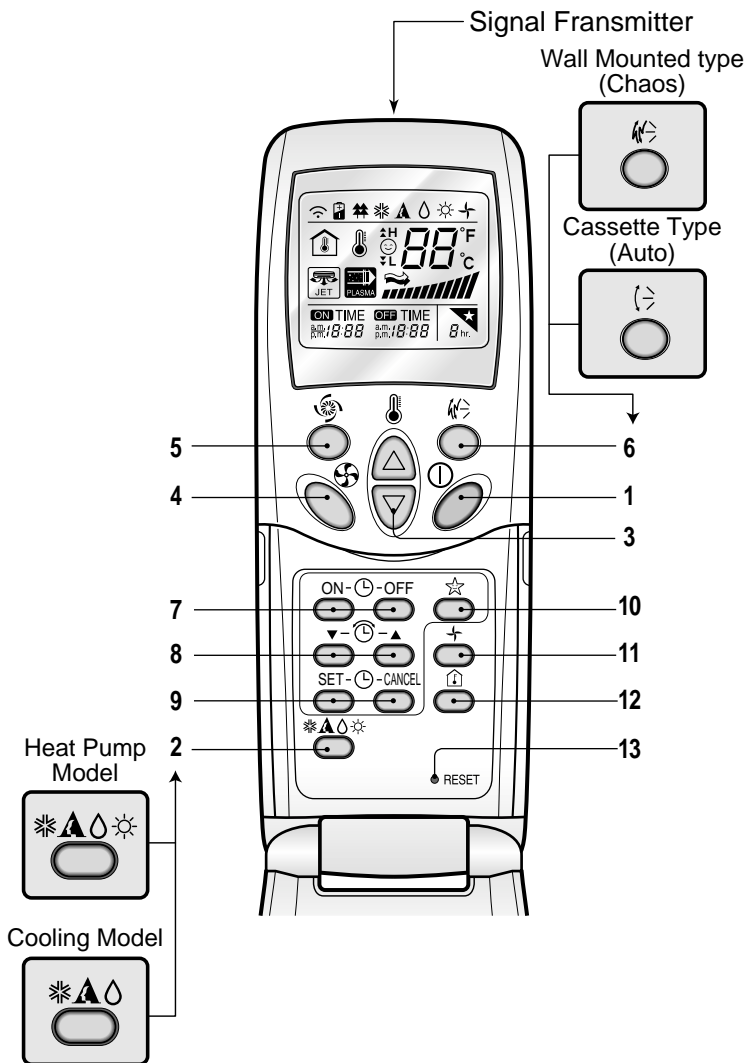

### 1 START/STOP BUTTON

Operation starts when this button is pressed and stops when the button is pressed again.

### 2 OPERATION MODE SELECTION BUTTON

Used to select the operation mode.

### 3 ROOM TEMPERATURE SETTING BUTTONS

Used to select the room temperature.

### 4 INDOOR FAN SPEED SELECTOR

Used to select fan speed in four steps low, medium, high, or CHAOS.

### 5 JET COOL

Used to start or stop the speed cooling. (Speed cooling operates super high fan speed in cooling mode.)

### 6 CHAOS/AUTO SWING BUTTON

Used to stop or start louver movement and set the desired up/down airflow direction.

### 7 ON/OFF TIMER BUTTONS

Used to set the time of starting and stopping operation.

### 8 TIME SETTING BUTTONS

Used to adjust the time.

### 9 TIMER SET/CANCEL BUTTONS

Used to set the timer when the desired time is obtained and to cancel the Timer operation.

### 10 SLEEP MODE AUTO BUTTON

Used to set Sleep Mode Auto operation.

### 11 AIR CIRCULATION BUTTON

Used to circulate the room air without cooling or heating (turns indoor fan on/off).

### 12 ROOM TEMPERATURE CHECKING BUTTON

Used to check the room temperature.

### 13 RESET BUTTON

Used prior to resetting time or after replacing batteries.



## 2. Wireless LCD Remote Control(Ceiling Cassette models)

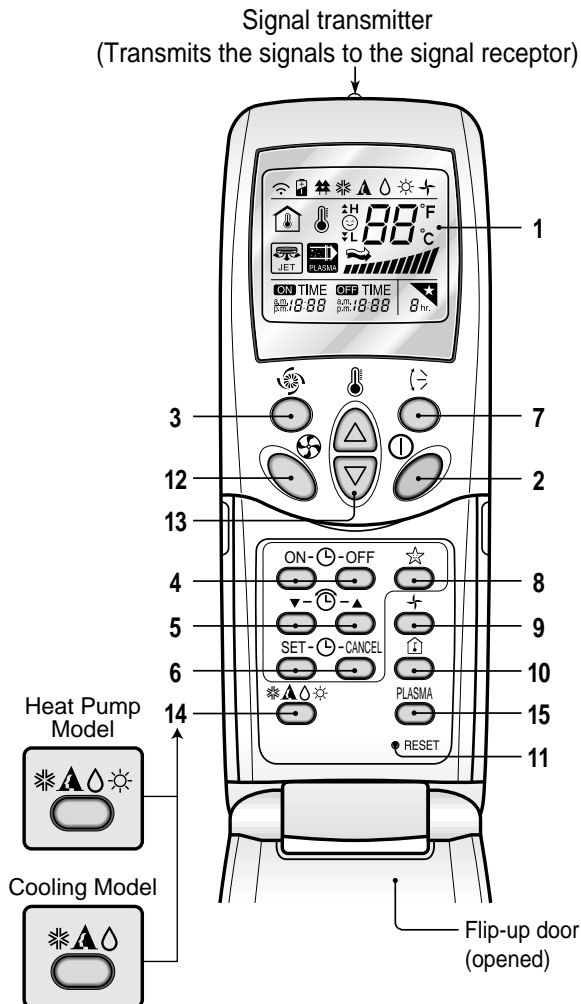

### 1 OPERATION DISPLAY

Displays the operation conditions.

### 2 ON/OFF BUTTON

Operation starts when this button is pressed and stops when the button is pressed again.

### 3 JET COOL BUTTON

Used to select jet cool mode.

### 4 ON/OFF TIMER BUTTONS

Used to set the time of starting and stopping operation.

### 5 TIME SETTING BUTTONS

Used to adjust the time.

### 6 TIMER SET/CANCEL BUTTONS

Used to set the timer when the desired time is obtained and to cancel the Timer operation.

### 7 AIR SWING BUTTON

Used to swing up and down.

### 8 SLEEP MODE BUTTON

Used to set Sleep Mode Auto operation.

### 9 AIR CIRCULATION BUTTON

Used to circulate the room air without cooling or heating (turns indoor fan on/off).

### 10 ROOM TEMPERATURE CHECKING BUTTON

Used to check the room temperature.

### 11 RESET BUTTON

Used prior to resetting time or after replacing batteries.

### 12 INDOOR FAN SPEED SELECTOR

Used to select fan speed in four steps-low, medium, high, or CHAOS.

### 13 ROOM TEMPERATURE SETTING BUTTONS

Used to select the room temperature.

### 14 OPERATION MODE SELECTION BUTTON

Used to select the operation mode.

### 15 PLASMA AIR CLEAN BUTTON(OPTIONAL)

## 4. Wireless LCD Remote Control(Ceiling Concealed Duct models)

### Remote Controller

#### Signal transmitter

Transmits the signals to the signal receptor.

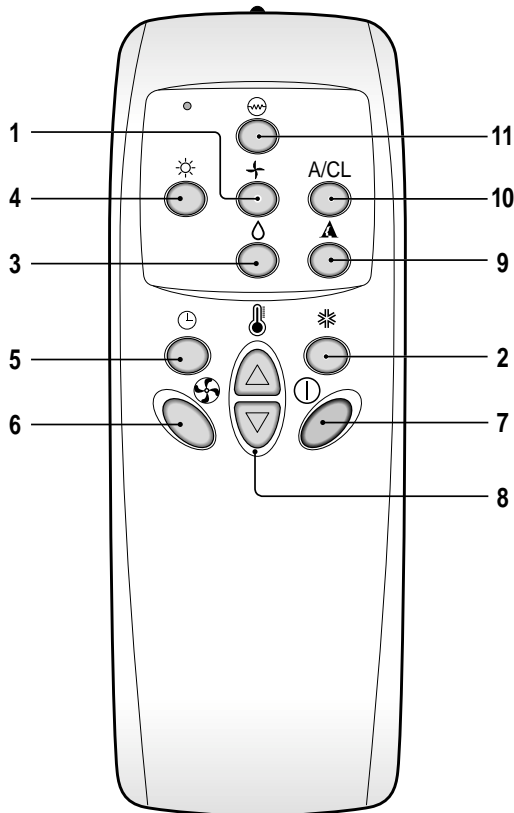

### 1 FAN Operation Button

Used to circulate room air without cooling or heating.

### 2 Cooling Operation Button

### 3 Soft Dry Operation Button

Used to dehumidify without overcooling.

### 4 Heating Operation Button

(Heat pump model only)

### 5 Timer Set Button

Used to set the timer when the desired time is obtained.

Then the wired remote controller is set up to 24 hours by an hour but the wireless remote controller is set up to 7 hours by an hour. Therefore, if you want to set over 7 hours, use the wired remote controller.

### 6 Fan Speed Button

Used to set the desired fan speed.

### 7 On/Off Button

Operation starts when this button is pressed, and stops when the button is pressed again.

### 8 Set Temperature Button

Used to set the temperature when the desired temperature is obtained

### 9 Auto Operation Button

### 10 Plasma Air Clean Button(Optional)

### 11 Electric Heater Button

(Optional: 48/60k Model only)

Used to set the Electric Heater.

### 3. Wireless LCD Remote Control(Ceiling Cassette models)

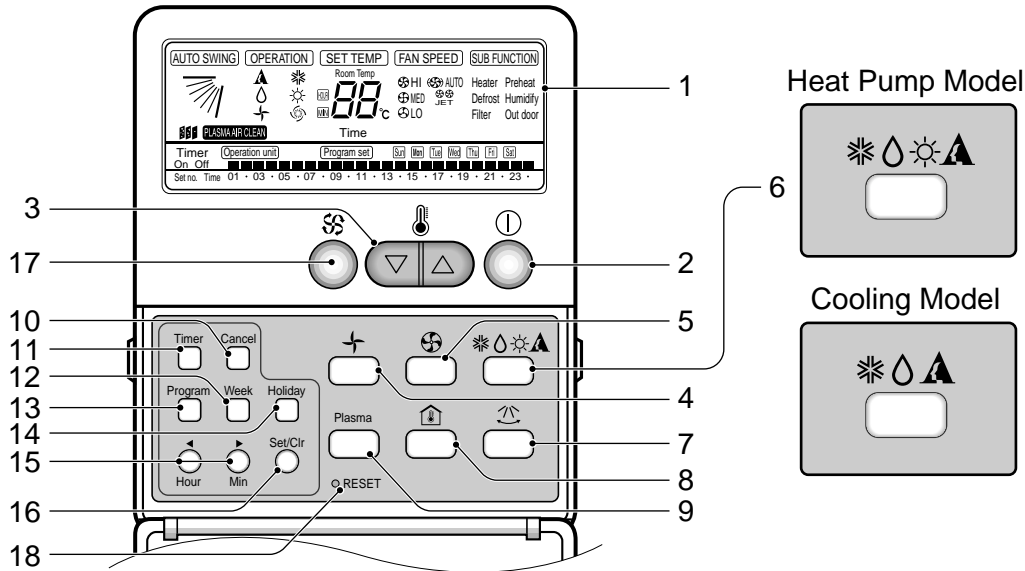

#### 1 Operation display

Displays the operation conditions.

#### 2 On/Off Button

Operation starts when this button is pressed, and stops when the button is pressed again.

#### 3 Set Temperature Button

Used to set the temperature when the desired temperature is obtained.

#### 4 FAN Operation Button

Used to circulate room air without cooling or heating.

#### 5 Fan Speed & Jet Cool Button

Used to set the desired fan speed and select jet cool mode.

#### 6 Operation Mode Selection Button

Used to select the operation mode.

- Auto Operation Mode
- Cooling Operation Mode
- Soft Dry Operation Mode
- Heating Operation Mode(except cooling model)

#### 7 Auto Swing Button

Used to swing up and down.

#### 8 Room Temperature Checking Button

Used to check the room temperature.

#### 9 Plasma Air Clean Button (optional)

#### 10 Timer Cancel Button

Used to cancel the timer.

#### 11 Timer Set Button

Used to set the timer when the desired time is obtained.

#### 12 Week Button

Used to set a day of the week.

#### 13 Program Button

Used to set the weekly timer.

#### 14 Holiday Button

Used to set a holiday of the week.

#### 15 Time Set Button

Used to set the time of the day and change the time in the weekly timer Function.

#### 16 Set and Clear Button

Used to set and clear the weekly timer.

#### 17 Swirl Button

Used to select swirl cool mode.

#### 18 Reset Button

Used to set the current time and clear the setting time.

## 5. Wired LCD Remote Control(Ceiling Concealed Duct models)

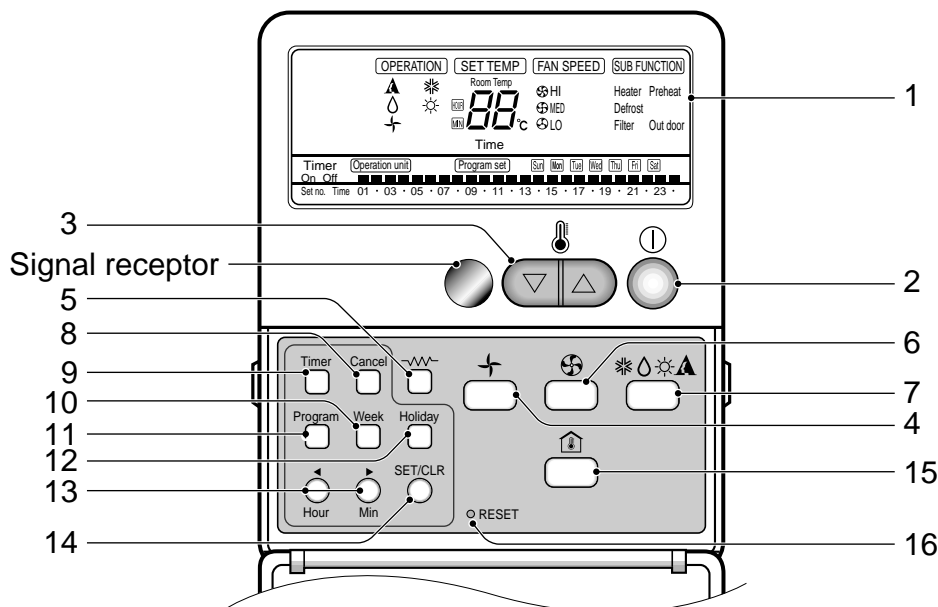

### 1 Operation display

Displays the operation conditions.

### 2 On/Off Button

Operation starts when this button is pressed, and stops when the button is pressed again.

### 3 Set Temperature Button

Used to set the temperature when the desired temperature is obtained.

### 4 FAN Operation Button

Used to circulate room air without cooling or heating.

### 5 Electric Heater Button(optional)

Used to set the Electric Heater.

### 6 Fan Speed Button

Used to set desired fan speed.

### 7 Operation Mode Selection Button

Used to select the operation mode.

- Auto Operation Mode.
- Cooling Operation Mode.
- Soft Dry Operation Mode.
- Heating Operation Mode.(except cooling model)

### 8 Timer Cancel Button

Used to cancel the timer.

### 9 Timer Set Button

Used to set the timer when the desired time is obtained.

### 10 Week Button

Used to set the day of the week.

### 11 Program Button

Used to set the weekly timer.

### 12 Holiday Button

Used to set a holiday of the week.

### 13 Time Setting Button

Used to set the time of the day and change the time in the weekly timer Function.

### 14 Set and Clear Button

Used to set and clear the weekly timer.

### 15 Room Temperature Checking Button

Used to check the room temperature.

### 16 Reset Button

Used to set the current time and clear the setting time.

# Specifications

## 1. Cooling Only

### Nominal 1.5 Ton

### Cooling Only

System	Indoor Unit		ATNC186ELAA, ATNC186ELCA	ABNC186HLAA	AVNC186BLAA
	Outdoor Unit		AUUC186A/AB		
	Decoration Panel		PT-CEA,CEC	-	-
Cooling Capacity	W(kcal/h)		5,422(4,662)	5,422(4,662)	5,803(4,990)
	Btu/h		18500	18500	19800
Heating Capacity	W(kcal/h)		-	-	-
	Btu/h		-	-	-
Input	Cooling/Heating	W	1840	1900	1840
Running Current	Cooling/Heating	A	8.4	8.7	8.3
Power Supply	ø,V,Hz		1,220-240, 50	1,220-240, 50	1,220-240, 50
Power Factor	%		95	94	95
E.E.R	Cooling	W/W(kcal/hW)	2.94(2.53)	2.85(2.45)	3.15(2.71)
		Btu/hW	10.05	9.74	10.76
C.O.P	Heating	W/W(kcal/hW)	-	-	-
		Btu/hW	-	-	-
Setting Temperature Range(cool/heat)		°C	18-30/-	18-30/-	18-30/-
Dehumidification Rate		l/h	2	2	2
Refrigerant Control			Capillary Tube	Capillary Tube	Capillary Tube
Refrigerant Charge		g(oz), type		1,000(35.3), R-410A	

Indoor Unit			ATNC186ELAA, ATNC186ELCA	ABNC186HLAA	AVNC186BLAA
Indoor fan motor	Output	W	25	118	30
	Model		IC-9630LGAD	IC-13450LG13C	IC-9430LGCG
	No. of Poles		6	4	4
	Input	W	100	180	53
	Running Current	A	0.75	0.92	0.23
	Capacitor	µF/Vac	2.5 / 440	6/370	1.5/370
Indoor Fan	Type		Turbo Fan	Sirocco Fan	Cross Flow Fan
	No. Used / Diameter	EA/mm(inch)	1/330(13.0)	2/177(7)	80(3.1)
Indoor Fan RPM	Cooling(H/M/L)	rpm	800 / 750 / 700	1395/1356/1270	1090/990/890
	Heating(H/M/L)	rpm	-	-	-
Air Circulation	Indoor (H/M/L)	CMM(CFM)	15/14/13(530/494/459)	16.5/14.5/13(583/512/459)	14/13/12(494/459/423)
Noise Level (Sound Press,1m)	Indoor(H/M/L)	dB(A)±3	43/41/39	36/34/32	43/40/37
Temperature Controller			Thermistor	Thermistor	Thermistor
Indoor Coil	Tube Size (OD)	inch(mm)	0.275(7)	0.275(7)	0.275(7)
	Fins per inch		21	21	20
	No. of Rows & Column		2R 11C	2R 10C	2R 14C
Dimensions (W*D*H)	Indoor	inch(mm)	22.4*22.4*10.5(570*570*269)	34.6*10.2*17.7 (880*260*450)	47.24*24.21*8.07(1200*615*205)
	Panel	inch(mm)	26.4*26.4*1.2(670*670*30)	-	-
Net Weight	Indoor	kg(lbs)	17(37.5)	28(61.7)	22(48.5)

Outdoor Unit			AUUC186A/AB
Compressor	Locked Rotor Amp.	A	32.3
	Type		Rotary
	Quantity	No.	1
	Model		5KS225D
	Maker		MATSUSHITA
	Capacity	W(Btu/h)	5,530(18,860)
	Motor Type		PSC
	Motor Input	W	1980
	Oil Type		RB68A or Freol Alpha68M
	Oil Charge	cc	600
Outdoor Coil	O.L.P Type(Model Name)		Internal
	Tube Size (OD)	inch(mm)	0.196(5)
	Fins per inch		21
Outdoor fan motor	No. of Rows & Column		2R 28C
	Output	W	67.2
Outdoor Fan	Model		IC-28640LG28P
	No. of Poles		6
	Input	W	120
	Running Current	A	0.54
	Capacitor	µF/Vac	6 / 370
	Type		Propeller
Air Circulation	No. Used / Diameter	EA/inch(mm)	1/18.1(460)
	Discharge	Side / Top	Side Discharge
	Speed	rpm	850
Noise Level (Sound Press,1m)	Outdoor	dB(A)±3	58(2048)
SVC Valve	Liquid	inch(mm)	50
			1 / 4 (6.35)
Dimensions (W*H*D)	Outdoor	inch(mm)	5 / 8 (15.88)
			33.0*22.6*0.8(840*575*275)
Net Weight	Outdoor	kg(lbs)	44(98.8)

Others			
Power Supply Cable(With Earth Cable)		No. * mm <sup>2</sup>	3 * 2.5
Conncting Cable(With Earth Cable)			4 * 0.75
Connecting Tube (ø. Socket Flare)	Liquid Side	inch(mm)	1 / 4 (6.35)
	Gas Side	inch(mm)	5 / 8 (15.88)
	Length, std	m	7.5
	Max length/elevation	m	50/30
Drain hose (ID ø)	Indoor Unit	mm	ø25
	Outdoor Unit	mm	-

- Notes:**
- Capacities are based on the following conditions:  
 Cooling: - Indoor Temperature 27°C(80.6°F) DB /19°C(66.2°F) WB  
 - Outdoor Temperature 35°C(95°F) DB /24°C(75.2°F) WB  
 - Interconnecting Piping Length 7.5m  
 - Level Difference of Zero.
  - Capacities are Net Capacities.
  - Due to our policy of innovation some specifications may be changed without notification.

Nominal 2 Ton

Cooling Only

System	Indoor Unit		ATNC246FLAA, ATNC246FLCA	ABNC246HLAA	AVNC246BLAA
	Outdoor Unit		AUUC246A/AB		
	Decoration Panel		PT-CFA,CFC	-	-
Cooling Capacity	W(kcal/h)		7,034(6,048)	7,034(6,048)	7,034(6,048)
	Btu/h		24000	24000	24000
Heating Capacity	W(kcal/h)		-	-	-
	Btu/h		-	-	-
Input	Cooling/Heating	W	2450	2450	2320
Running Current	Cooling/Heating	A	10.8	11	10.3
Power Supply	ø, V, Hz		1, 220-240, 50	1, 220-240, 50	1, 220-240, 50
Power Factor	%		93	93	93
E.E.R	Cooling	W/W(kcal/hW)	2.87(2.47)	2.87(2.47)	3.03(2.60)
		Btu/hW	9.8	9.8	10.34
C.O.P	Heating	W/W(kcal/hW)	-	-	-
		Btu/hW	-	-	-
Setting Temperature Range(cool/heat)	°C		18-30/-	18-30/-	18-30/-
Dehumidification Rate	l/h		3.3	3.3	3.3
Refrigerant Control			Capillary Tube	Capillary Tube	Capillary Tube
Refrigerant Charge	g(oz), type			1,200(42.4), R-410A	

Indoor Unit			ATNC246FLAA, ATNC246FLCA	ABNC246HLAA	AVNC246BLAA
Indoor fan motor	Output	W	40.3	118	35
	Model		OEM-3502P2	IC-13450LG13C	IC-9430LGCE
	No. of Poles		6	4	4
	Input	W	121	180	63
	Running Current	A	0.53	0.92	0.27
Capacitor	µF/Vac	4.0/ 440	6/370	1.5/370	
Indoor Fan	Type		Turbo Fan	Sirocco Fan	Cross Flow Fan
	No. Used / Diameter	EA/mm(inch)	1/382(15)	2/177(7)	1/80(3.1)
Indoor Fan RPM	Cooling(H/M/L)	rpm	600 / 540 / 480	1417/1350/1255	1160/1060/960
	Heating(H/M/L)	rpm	-	-	-
Air Circulation	Indoor (H/M/L)	CMM(CFM)	15/14/13(530/494/459)	18/16.5/14(636/583/494)	15/14/13(530/494/459)
Noise Level (Sound Press,1m)	Indoor(H/M/L)	dB(A)±3	43/41/38	37/35/33	45/42/39
Temperature Controller			Thermistor	Thermistor	Thermistor
Indoor Coil	Tube Size (OD)	inch(mm)	0.275(7)	0.275(7)	0.275(7)
	Fins per inch		21	21	20
	No. of Rows & Column		2R 12C	3R 10C	2R 14C
Dimensions (W*D*H)	Indoor	inch(mm)	29.3*29.4*11.5(744*744*292)	34.6*10.2*17.7 (880*260*450)	47.24*24.21*8.07(1200*615*205)
	Panel	inch(mm)	33.5*33.5*1.18(850*850*30)	-	-
Net Weight	Indoor	kg(lbs)	26(57.3)	28(61.7)	22(48.5)

Outdoor Unit			AUUC246A/AB		
Compressor	Locked Rotor Amp.	A	62		
	Type		Rotary		
	Quantity	No.	1		
	Model		GP290P		
	Maker		LG		
	Capacity	W(Btu/h)	6,250(24,800)		
	Motor Type		PSC		
	Motor Input	W	2505		
	Oil Type		FVC68D		
	Oil Charge	cc	1130		
O.L.P Type(Model Name)		Internal			
Outdoor Coil	Tube Size (OD)	inch(mm)	0.196(5)		
	Fins per inch		21		
	No. of Rows & Column		2R 30C		
Outdoor fan motor	Output	W	67.2		
	Model		IC-28640LG28P		
	No. of Poles		6		
	Input	W	120		
	Running Current	A	0.54		
Capacitor	µF/Vac		6 / 370		
Outdoor Fan	Type		Propeller		
	No. Used / Diameter	EA/inch(mm)	1/18.1(460)		
	Discharge	Side / Top	Side Discharge		
	Speed	rpm	850		
Air Circulation	Outdoor	CMM(CFM)	58(2048)		
Noise Level (Sound Press,1m)	Outdoor	dB(A)±3	50		
SVC Valve	Liquid	inch(mm)	1 / 4 (6.35)		
	Gas	inch(mm)	5 / 8 (15.88)		
Dimensions (W*H*D)	Outdoor	inch(mm)	34.2*25.8*12.6(870*655*320)		
Net Weight	Outdoor	kg(lbs)	57(125.6)		

Others			
Power Supply Cable(With Earth Cable)	No.* mm <sup>2</sup>	3 * 2.5	
Conneccting Cable(With Earth Cable)	inch(mm)	4 * 0.75	
Connecting Tube (ø. Socket Flare)	Liquid Side	inch(mm)	1 / 4 (6.35)
	Gas Side	inch(mm)	5 / 8 (15.88)
	Length, std	m	7.5
	Max length/elevation	m	50/30
Drain hose (ID ø)	Indoor Unit	mm	ø25
	Outdoor Unit	mm	-

**Notes:** 1. Capacities are based on the following conditions:  
 Cooling: - Indoor Temperature 27°C(80.6°F) DB /19°C(66.2°F) WB  
 - Outdoor Temperature 35°C(95°F) DB /24°C(75.2°F) WB  
 - Interconnecting Piping Length 7.5m  
 - Level Difference of Zero.

2. Capacities are Net Capacities.  
 3. Due to our policy of innovation some specifications may be changed without notification.

**Nominal 2.5 Ton**

**Cooling Only**

System	Indoor Unit		ATNC306FLAA, ATNC306FLCA	ABNC306GLAA	AVNC306BLAA
	Outdoor Unit		PT-CFA,CFC	AUUC306A/AB	-
	Decoration Panel				
Cooling Capacity		W(kcal/h)	8,352(7,182)	8,792(7,560)	8,352(7,182)
		Btu/h	28500	30000	28500
Heating Capacity		W(kcal/h)	-	-	-
		Btu/h	-	-	-
Input	Cooling/Heating	W	2800	2950	2730
Running Current	Cooling/Heating	A	13.0	13.6	12.9
Power Supply		ø, V, Hz	1, 220-240, 50	1, 220-240, 50	1, 220-240, 50
Power Factor		%	93	94	92
E.E.R	Cooling	W/W(kcal/hW)	2.98(2.56)	2.98(2.56)	3.06(2.63)
		Btu/hW	10.17	10.17	10.44
C.O.P	Heating	W/W(kcal/hW)	-	-	-
		Btu/hW	-	-	-
Setting Temperature Range(cool/heat)		°C	18-30/-	18-30/-	18-30/-
Dehumidification Rate		l/h	3.5	3.5	3.5
Refrigerant Control			Capillary Tube	Capillary Tube	Capillary Tube
Refrigerant Charge		g(oz), type		1,950(68.8), R-410A	

Indoor Unit			ATNC306FLAA, ATNC306FLCA	ABNC306GLAA	AVNC306BLAA
Indoor fan motor	Output	W	-	124	-
	Model		OBM-4015P2	IC-13450LG13J	IC-9430LGCL
	No. of Poles		6	4	4
	Input	W	146	300	81
	Running Current	A	0.67	1.34	0.36
Indoor Fan	Capacitor	µF/Vac	4/440	6/370	1.5/ 370
	Type		Turbo Fan	Sirocco Fan	Cross Flow Fan
Indoor Fan RPM	No. Used / Diameter	EA/mm(inch)	1/382(15)	2/177(7)	80(3.1)
	Cooling(H/M/L)	rpm	650 / 600 / 550	1415/1359/1290	1160/1060/960
Air Circulation	Heating(H/M/L)	rpm	-	-	-
	Indoor (H/M/L)	CMM(CFM)	19/17/15(671/600/530)	26.5/23/20(936/812/706)	18/16/14(636/564/494)
Noise Level (Sound Press, 1m)	Indoor(H/M/L)	dB(A)±3	45/42/39	42/40/38	45/42/39
Temperature Controller			Thermistor	Thermistor	Thermistor
Indoor Coil	Tube Size (OD)	inch(mm)	0.275(7)	0.275(7)	0.275(7)
	Fins per inch		21	21	20
	No. of Rows & Column		2R 12C	3R 12C	2R 14C
Dimensions (W*D*H)	Indoor	inch(mm)	29.3*29.4*11.5(744*744*292)	46.4*11.7*17.7(1180*298*450)	47.24*24.21*8.07(1200*615*205)
	Panel	inch(mm)	33.5*33.5*1.18(850*850*30)	-	-
Net Weight	Indoor	kg(lbs)	26(57.3)	38(83.8)	22(48.5)

Outdoor Unit			AUUC306A/AB		
Compressor	Locked Rotor Amp.	A	68		
	Type		Rotary		
	Quantity	No.	1		
	Model		5JS330D		
	Maker		MATSUSHITA		
	Capacity	W(Btu/h)	8,235(28,097)		
	Motor Type		PSC		
	Motor Input	W	2915		
	Oil Type		FV50S		
	Oil Charge	cc	1130		
Outdoor Coil	O.L.P Type(Model Name)		Internal		
	Tube Size (OD)	inch(mm)	0.275(7)		
	Fins per inch		18		
Outdoor fan motor	No. of Rows & Column		2R 36C		
	Output	W	67.2		
	Model		IC-28640LG28P		
	No. of Poles		6		
	Input	W	120		
Outdoor Fan	Running Current	A	0.54		
	Capacitor	µF/Vac	6 / 370		
	Type		Propeller		
	No. Used / Diameter	EA/inch(mm)	1/18.1(460)		
	Discharge	Side / Top	Side Discharge		
Air Circulation	Speed	rpm	850		
Noise Level (Sound Press, 1m)	Outdoor	CMM(CFM)	58(2048)		
SVC Valve	Outdoor	dB(A)±3	54		
	Liquid	inch(mm)	1 / 4 (6.35)		
Dimensions (W*H*D)	Gas	inch(mm)	5 / 8 (15.88)		
	Outdoor	inch(mm)	34.2*31.5*12.6(870*800*320)		
Net Weight	Outdoor	kg(lbs)	60(132.2)		

Others			
Power Supply Cable(With Earth Cable)		No.* mm <sup>2</sup>	3 * 2.5
Connecting Cable(With Earth Cable)			3 * 0.75
Connecting Tube (ø. Socket Flare)	Liquid Side	inch(mm)	1 / 4 (6.35)
	Gas Side	inch(mm)	5 / 8 (15.88)
	Length, std	m	7.5
	Max length/elevation	m	50/30
	Drain hose (ID ø)	Indoor Unit	mm
Outdoor Unit		mm	-

- Notes:**
- Capacities are based on the following conditions:  
 Cooling: - Indoor Temperature 27°C(80.6°F) DB /19°C(66.2°F) WB  
 - Outdoor Temperature 35°C(95°F) DB /24°C(75.2°F) WB  
 - Interconnecting Piping Length 7.5m  
 - Level Difference of Zero.
  - Capacities are Net Capacities.
  - Due to our policy of innovation some specifications may be changed without notification.

**Nominal 3 Ton**

**Cooling Only**

System	Indoor Unit		ATNC368DLAA, ATNC368DLCA		ABNC368GLAA	
	Outdoor Unit		AUUC368A/AB			
	Decoration Panel		PT-CDA,CDC			
Cooling Capacity	W(kcal/h)		10,550(9,072)		10,550(9,072)	
	Btu/h		36000		36000	
Heating Capacity	W(kcal/h)		-		-	
	Btu/h		-		-	
Input	Cooling/Heating	W	3760		3850	
Running Current	Cooling/Heating	A	6.5		6.6	
Power Supply		ø, V, Hz	3, 380-415, 50		3, 380-415, 50	
Power Factor		%	83		84	
E.E.R	Cooling	W/W(kcal/hW)	2.80(2.41)		2.73(2.35)	
		Btu/hW	9.57		9.35	
C.O.P	Heating	W/W(kcal/hW)	-		-	
		Btu/hW	-		-	
Setting Temperature Range(cool/heat)		°C	18-30/-		18-30/-	
Dehumidification Rate		l/h	4		4	
Refrigerant Control			Capillary Tube		Capillary Tube	
Refrigerant Charge		g(oz), type	2,200(77.6), R-410A		2,200(77.6), R-410A	

Indoor Unit			ATNC368DLAA, ATNC368DLCA		ABNC368GLAA	
Indoor fan motor	Output	W	52.5		272	
	Model		IC-1630LGPJ		IC-13450LG13A	
	No. of Poles		6		4	
	Input	W	175		323	
	Running Current	A	0.76		1.42	
Capacitor	µF/Vac		4 / 450		6/370	
	Type		Turbo Fan		Sirocco Fan	
Indoor Fan	No. Used / Diameter		EA/mm(inch)		-	
			1/460(18.1)		-	
Indoor Fan RPM	Cooling(H/M/L)	rpm	560 / 520 /480		1415/1359/1290	
	Heating(H/M/L)	rpm	-		-	
Air Circulation	Indoor (H/M/L)	CMM(CFM)	25/23/21(883/812/742)		32/29/26.5 (1130/1024/936)	
Noise Level (Sound Press,1m)	Indoor(H/M/L)	dB(A)±3	40/38/36		42/40/38	
Temperature Controller	Tube Size (OD)		Thermistor		Thermistor	
	Fins per inch		0.275(7)		0.275(7)	
Indoor Coil	No. of Rows & Column		21		21	
			2R 12C		3R12C	
Dimensions (W*D*H)	Indoor	inch(mm)	33.0*33.0*11.3(840*840*288)		46.4*11.7 *17.71(1180*298*450)	
	Panel	inch(mm)	37.4*37.4*1.2(950*950*30)		-	
Net Weight	Indoor	kg(lbs)	33(72.7)		38(83.8)	

Outdoor Unit			AUUC368A/AB	
Compressor	Locked Rotor Amp.	A	47	
	Type		Scroll	
	Quantity	No.	1	
	Model		AQ042YA	
	Maker		LG	
	Capacity	W(Btu/h)	10,258(35,000)	
	Motor Type		Condenser Inducted	
	Motor Input	W	3608	
	Oil Type		FVC68ST	
	Oil Charge	cc	1200	
O.L.P Type(Model Name)			Internal	
	Tube Size (OD)	inch(mm)	0.275(7)	
	Fins per inch		18	
Outdoor Coil	No. of Rows & Column		2R 48C	
	Output	W	41	
Outdoor fan motor	Model		IC-9625LGSY	
	No. of Poles		6	
	Input	W	80	
	Running Current	A	0.35	
	Capacitor	µF/Vac	2 / 370	
Outdoor Fan	Type		Propeller	
	No. Used / Diameter		EA/inch(mm)	
			2 /15.7(400)	
	Discharge	Side / Top	Side Discharge	
Speed	rpm	880		
Air Circulation	Outdoor	CMM(CFM)	105(3708)	
Noise Level (Sound Press,1m)	Outdoor	dB(A)±3	52	
SVC Valve	Liquid	inch(mm)	1 / 4 (6.35)	
	Gas		5 / 8 (15.88)	
Dimensions (W*H*D)	Outdoor	inch(mm)	35.3*41.7*12.6(870*1060*320)	
Net Weight	Outdoor	kg(lbs)	85(187.3)	

Others			
Power Supply Cable(With Earth Cable)	No.* mm <sup>2</sup>	5 * 3.5	
Conneccting Cable(With Earth Cable)		4 * 1.25	
Connecting Tube (ø. Socket Flare)	Liquid Side	inch(mm)	1 / 4 (6.35)
	Gas Side	inch(mm)	5 / 8 (15.88)
	Length, std	m	7.5
	Max length/elevation	m	50/30
Drain hose (ID ø)	Indoor Unit	mm	ø25
	Outdoor Unit	mm	-

**Notes:** 1. Capacities are based on the following conditions:  
 Cooling: - Indoor Temperature 27°C(80.6°F) DB /19°C(66.2°F) WB  
 - Outdoor Temperature 35°C(95°F) DB /24°C(75.2°F) WB  
 - Interconnecting Piping Length 7.5m  
 - Level Difference of Zero.

2. Capacities are Net Capacities.  
 3. Due to our policy of innovation some specifications may be changed without notification.



**Nominal 4 Ton**

**Cooling Only**

System	Indoor Unit		ATNC488DLAA, ATNC488DLCA	ABNC488ELAA
	Outdoor Unit		AUUC488A/AB	
	Decoration Panel		PT-CDA,CDC	
Cooling Capacity		W(kcal/h) Btu/h	14,067(12,096) 48000	14,067(12,096) 48000
Heating Capacity		W(kcal/h) Btu/h	- -	- -
Input	Cooling/Heating	W	5300	5780
Running Current	Cooling/Heating	A	9.3	9.9
Power Supply		ø, V, Hz	3, 380-415, 50	3, 380-415, 50
Power Factor		%	82	84
E.E.R	Cooling	W/W(kcal/hW) Btu/hW	2.65(2.28) 9.05	2.43(2.09) 8.3
		W/W(kcal/hW) Btu/hW	- -	- -
C.O.P	Heating	W/W(kcal/hW) Btu/hW	- -	- -
Setting Temperature Range(cool/heat)		°C	18-30/-	18-30/-
Dehumidification Rate		l/h	5.5	5.5
Refrigerant Control			Capillary Tube	Capillary Tube
Refrigerant Charge		g(oz), type	4,050(142.8), R-410A	

Indoor Unit			ATNC488DLAA, ATNC488DLCA	ABNC488ELAA
Indoor fan motor	Output	W	58.5	391
	Model		IC-1640L.GPH	808555AVA-A12EX
	No. of Poles		6	4
	Input	W	195	662
	Running Current	A	1.5	2.92
Indoor Fan	Capacitor	µF/Vac	6 / 400	12 / 450
	Type		Turbo Fan	Sirocco Fan
Indoor Fan RPM	No. Used / Diameter	EA/mm(inch)	1/460(18.1)	-
	Cooling(H/M/L) Heating(H/M/L)	rpm	600 / 555 / 520	1085/1024/970
Air Circulation	Indoor (H/M/L)	CMM(CFM)	30/28/26(1059/988/918)	40/36/30(1413/1271/1059)
Noise Level (Sound Press, 1m)	Indoor(H/M/L)	dB(A)±3	43/41/39	44/42/40
Temperature Controller			Thermistor	Thermistor
Indoor Coil	Tube Size (OD)	inch(mm)	0.275(7)	0.375(9.52)
	Fins per inch		21	17
	No. of Rows & Column		2R 12C	3R14C
Dimensions (W*D*H)	Indoor	inch(mm)	33.0*33.0*11.3(840*840*288)	48.43*14.57*26.77(1230*370*680)
	Panel	inch(mm)	37.4*37.4*1.2(950*950*30)	-
Net Weight	Indoor	kg(lbs)	33(72.7)	68(149.9)

Outdoor Unit			AUUC488A/AB	
Compressor	Locked Rotor Amp.	A	63	
	Type		Scroll	
	Quantity	No.	1	
	Model		AR061YA	
	Maker		LG	
	Capacity	W(Btu/h)	14,888(50,800)	
	Motor Type		Condenser Inducted	
	Motor Input	W	5347	
	Oil Type		FVC68ST	
	Oil Charge	cc	1800	
Outdoor Coil	O.L.P Type(Model Name)		Internal	
	Tube Size (OD)	inch(mm)	0.375(9.52)	
	Fins per inch		18	
Outdoor fan motor	No. of Rows & Column		2R 44C	
	Output	W	72	
	Model		OBM-4006P2	
	No. of Poles		6	
	Input	W	151	
Outdoor Fan	Running Current	A	0.63	
	Capacitor	µF/Vac	6 / 370	
	Type		Propeller	
	No. Used / Diameter	EA/inch(mm)	2/18.1(460)	
	Discharge	Side / Top	Side Discharge	
Air Circulation	Outdoor	CMM(CFM)	105(3708)	
Noise Level (Sound Press, 1m)	Outdoor	dB(A)±3	56	
SVC Valve	Liquid	inch(mm)	3 / 8 (9.52)	
	Gas		3 / 4 (19.05)	
Dimensions (W*H*D)	Outdoor	inch(mm)	35.4*48.2*14.6(900*1225*370)	
Net Weight	Outdoor	kg(lbs)	93 (205.0)	

Others		
Power Supply Cable(With Earth Cable)		No.* mm <sup>2</sup>
Connecting Cable(With Earth Cable)		
Connecting Tube (ø. Socket Flare)	Liquid Side	inch(mm)
	Gas Side	inch(mm)
	Length, std	m
	Max length/elevation	m
	Indoor Unit	mm
Drain hose (ID ø)	Indoor Unit	mm
	Outdoor Unit	mm

- Notes:**
- Capacities are based on the following conditions:  
 Cooling: - Indoor Temperature 27°C(80.6°F) DB /19°C(66.2°F) WB  
 - Outdoor Temperature 35°C(95°F) DB /24°C(75.2°F) WB  
 - Interconnecting Piping Length 7.5m  
 - Level Difference of Zero.
  - Capacities are Net Capacities.
  - Due to our policy of innovation some specifications may be changed without notification.

**Nominal 5 Ton**

**Cooling Only**

System	Indoor Unit		ATNC608DLAA, ATNC608DLCA	ABNC608ELAA
	Outdoor Unit		AUUC608A/AB	
	Decoration Panel		PT-CDA,CDC	
Cooling Capacity		W(kcal/h) Btu/h	15,826(13,608) 54000	16,999(14,616) 58000
Heating Capacity		W(kcal/h) Btu/h	- -	- -
Input	Cooling/Heating	W	6450	7060
Running Current	Cooling/Heating	A	10.5	11.4
Power Supply		ø, V, Hz	3, 380-415, 50	3, 380-415, 50
Power Factor		%	88	89
E.E.R	Cooling	W/W(kcal/hW) Btu/hW	2.40(2.07) 8.22	2.40(2.07) 8.21
C.O.P	Heating	W/W(kcal/hW) Btu/hW	- -	- -
Setting Temperature Range(cool/heat)		°C	18-30/-	18-30/-
Dehumidification Rate		l/h	6.5	6.5
Refrigerant Control			Capillary Tube	Capillary Tube
Refrigerant Charge		g(oz), type	5,200(183.4), R-410A	

Indoor Unit			ATNC608DLAA, ATNC608DLCA	ABNC608ELAA
Indoor fan motor	Output	W	107	389
	Model		IC-14640L GPM	808555PVA-A18EX
	No. of Poles		6	4
	Input	W	237	670
	Running Current	A	1.8	2.9
Indoor Fan	Capacitor	µF/Vac	6 / 400	15 / 450
	Type		Turbo Fan	Sirocco Fan
Indoor Fan RPM	No. Used / Diameter	EA/mm(inch)	1/460(18.1)	-
	Cooling(H/M/L) Heating(H/M/L)	rpm	700 / 650 / 600	1260/1196/1125/1052
Air Circulation	Indoor (H/M/L)	CMM(CFM)	34/32/30(1200/1130/1059)	49/45/40/35(1730/1589/1413/1236)
Noise Level (Sound Press,1m)	Indoor(H/M/L)	dB(A)±3	50/47/43	49/46/44/42
Temperature Controller			Thermistor	Thermistor
Indoor Coil	Tube Size (OD)	inch(mm)	0.275(7)	0.375(9.52)
	Fins per inch		21	19
	No. of Rows & Column		2R 12C	4R14C
Dimensions (W*D*H)	Indoor	inch(mm)	33.0*33.0*11.3(840*840*288)	48.43*14.57*26.77(1230*370*680)
	Panel	inch(mm)	37.4*37.4*1.2(950*950*30)	-
Net Weight	Indoor	kg(lbs)	33(72.7)	70(154.3)

Outdoor Unit			AUUC608A/AB	
Compressor	Locked Rotor Amp.	A	81	
	Type		Reciprocating	
	Quantity	No.	1	
	Model		H89A723DBVA	
	Maker		Bristol	
	Capacity	W(Btu/h)	17,740(60,529)	
	Motor Type		Condenser Inducted	
	Motor Input	W	5717	
	Oil Type		Mobil EAL Arctic 32 BC(POE)	
	Oil Charge	cc	1922	
Outdoor Coil	O.L.P Type(Model Name)		Internal	
	Tube Size (OD)	inch(mm)	0.375(9.52)	
	Fins per inch		18	
Outdoor fan motor	No. of Rows & Column		2R 44C	
	Output	W	72	
	Model		OBM-4006P2	
	No. of Poles		6	
	Input	W	151	
Outdoor Fan	Running Current	A	0.63	
	Capacitor	µF/Vac	6 / 370	
	Type		Propeller	
	No. Used / Diameter	EA/inch(mm)	2/18.1(460)	
	Discharge	Side / Top	Side Discharge	
Air Circulation	Outdoor	CMM(CFM)	105(3708)	
Noise Level (Sound Press,1m)	Outdoor	dB(A)±3	880	
SVC Valve	Liquid	inch(mm)	1 / 2 (12.7)	
	Gas		3 / 4 (19.05)	
Dimensions (W*H*D)	Outdoor	inch(mm)	35.4*48.2*14.6(900*1225*370)	
Net Weight	Outdoor	kg(lbs)	93 (205.0)	

Others			
Power Supply Cable(With Earth Cable)		No.* mm <sup>2</sup>	5 * 3.5
Conneccting Cable(With Earth Cable)			4 * 1.25
Connecting Tube (ø. Socket Flare)	Liquid Side	inch(mm)	1 / 2 (12.7)
	Gas Side	inch(mm)	3 / 4 (19.05)
	Length, std	m	7.5
	Max length/elevation	m	50/30
	Drain hose (ID ø)	Indoor Unit	mm
Outdoor Unit		mm	-

- Notes:**
- Capacities are based on the following conditions:  
 Cooling: - Indoor Temperature 27°C(80.6°F) DB /19°C(66.2°F) WB  
 - Outdoor Temperature 35°C(95°F) DB /24°C(75.2°F) WB  
 - Interconnecting Piping Length 7.5m  
 - Level Difference of Zero.
  - Capacities are Net Capacities.
  - Due to our policy of innovation some specifications may be changed without notification.

## 2. Heat Pump

### Nominal 1.5 Ton

### Heat Pump

System	Indoor Unit		ATNH186ELAA, ATNH186ELCA	ABNH186HLAA	AVNH186BLAA
	Outdoor Unit			AUUH186A/AB	
	Decoration Panel		PT-HEA,PT-HEC	-	-
Cooling Capacity	W(kcal/h)		5,276(4,536)	5,276(4,536)	5,334(4,587)
	Btu/h		18000	18000	18200
Heating Capacity	W(kcal/h)		5,803(4,990)	5,803(4,990)	5,920(5,091)
	Btu/h		19800	19800	20200
Input	Cooling/Heating	W	1,820/1,950	1,840/1,970	1,770/1,790
Running Current	Cooling/Heating	A	8.2/8.8	8.3/8.9	7.9/7.9
Power Supply	ø,V,Hz		1, 220-240, 50	1, 220-240, 50	1, 220-240, 50
Power Factor	%		97	96	97
E.E.R	Cooling	W/W(kcal/hW)	2.90(2.49)	2.87(2.47)	3.01(2.59)
		Btu/hW	9.89	9.78	10.28
C.O.P	Heating	W/W(kcal/hW)	3.19(2.56)	2.95(2.53)	3.31(2.84)
		Btu/hW	10.88	10.05	11.28
Setting Temperature Range(cool/heat)	°C		18-30/16-30	18-30/16-30	18-30/16-30
Dehumidification Rate	l/h		2	2	2
Refrigerant Control			Capillary Tube	Capillary Tube	Capillary Tube
Refrigerant Charge	g(oz), type			1,300(45.9), R-410A	

Indoor Unit			ATNH186ELAA, ATNH186ELCA	ABNH186HLAA	AVNH186BLAA
Indoor fan motor	Output	W	25	118	30
	Model		IC-9630LGAD	IC-13450LG13C	IC-9430LGCG
	No. of Poles		6	4	4
	Input	W	100	180	53
Running Current	A		0.75	0.92	0.23
	Capacitor	µF/Vac	2.5 / 440	6/370	1.5/370
Indoor Fan	Type		Turbo Fan	Sirocco Fan	Cross Flow Fan
	No. Used / Diameter	EA/mm(inch)	1/330(13.0)	2/177(7)	1/80(3.1)
Indoor Fan RPM	Cooling(H/M/L)	rpm	800 / 750 / 700	1395/1356/1270	1090/990/890
	Heating(H/M/L)	rpm	800 / 750 / 700	1395/1356/1270	1090/990/890
Air Circulation	Indoor (H/M/L)	CMM(CFM)	15/14/13(530/494/459)	16.5/14.5/13(583/512/459)	14/13/12(494/459/423)
Noise Level (Sound Press,1m)	Indoor(H/M/L)	dB(A)±3	43/41/39	36/34/32	43/40/37
Temperature Controller			Thermistor	Thermistor	Thermistor
Indoor Coil	Tube Size (OD)	inch(mm)	0.275(7)	0.275(7)	0.275(7)
	Fins per inch		21	21	20
	No. of Rows & Column		2R 11C	2R 10C	2R 14C
Dimensions (W*D*H)	Indoor	inch(mm)	22.4*22.4*10.5(570*570*269)	34.6*10.2*17.7 (880*260*450)	47.2*24.21*8.07(1200*615*205)
	Panel	inch(mm)	26.4*26.4*1.2(670*670*30)		
Net Weight	Indoor	kg(lbs)	17(37.5)	28(61.7)	22(48.5)

Outdoor Unit			AUUH186A/AB
Compressor	Locked Rotor Amp.	A	32.3
	Type		Rotary
	Quantity	No.	1
	Model		5KS225D
	Maker		MATSUSHITA
	Capacity	W(Btu/h)	5,530(18,860)
	Motor Type		PSC
	Motor Input	W	1980
	Oil Type		FV50S
	Oil Charge	cc	600
Outdoor Coil	O.L.P Type(Model Name)		Internal
	Tube Size (OD)	inch(mm)	0.275(7)
	Fins per inch		18
No. of Rows & Column			2R 28C
	Output	W	67.2
Outdoor fan motor	Model		IC-28640LG28P
	No. of Poles		6
	Input	W	120
	Running Current	A	0.54
Capacitor	µF/Vac		6 / 370
Outdoor Fan	Type		Propeller
	No. Used / Diameter	EA/inch(mm)	1/18,1(460)
	Discharge	Side / Top	Side Discharge
Speed	rpm		850
Air Circulation	Outdoor	CMM(CFM)	58(2048)
Noise Level (Sound Press,1m)	Outdoor	dB(A)±3	52
SVC Valve	Liquid	inch(mm)	1 / 4 (6.35)
	Gas	inch(mm)	5 / 8 (15.88)
Dimensions (W*H*D)	Outdoor	inch(mm)	34.2*25.8*12.6(870*655*320)
Net Weight	Outdoor	kg(lbs)	52(114.6)

Others			
Power Supply Cable(With Earth Cable)		3 * 2.5	
Conncting Cable(With Earth Cable)	No. * mm <sup>2</sup>	5 * 0.75	
Connecting Tube (ø. Socket Flare)	Liquid Side	inch(mm)	1 / 4 (6.35)
	Gas Side	inch(mm)	5 / 8 (15.88)
	Length, std	m	7.5
	Max length/elevation	m	50/30
Drain hose (ID ø)	Indoor Unit	mm	ø25
	Outdoor Unit	mm	ø32

Notes: 1. Capacities are based on the following conditions:

- Cooling: - Indoor Temperature 27°C(80.6°F) DB /19°C(66.2°F)WB
- Outdoor Temperature 35°C(95°F) DB /24°C(75.2°F)WB
- Interconnecting Piping Length 7.5m
- Level Difference of Zero.

2. Capacities are Net Capacities.

3. Due to our policy of innovation some specifications may be changed without notification.

- Heating:- Indoor Temperature 20°C(68°F) DB / 15°C(59°F)WB
- Outdoor Temperature 7°C(44.6°F) DB / 6°C(42.8°F)WB
- Interconnecting Piping Length 7.5 m
- Level Difference of Zero.

Nominal 2 Ton

Heat Pump

System	Indoor Unit		ATNH246FLAA, ATNH246FLCA	ABNH246HLAA	AVNH246BLAA
	Outdoor Unit		AUUH246A/AB		
	Decoration Panel		PT-HFA,PT-HFC	-	-
Cooling Capacity	W(kcal/h)		7,034(6,048)	7,034(6,048)	7,034(6,048)
	Btu/h		24000	24000	24000
Heating Capacity	W(kcal/h)		7,767(6,678)	7,854(6,754)	7,737(6,653)
	Btu/h		26500	26800	26400
Input	Cooling/Heating	W	2,400/2,380	2,400/2,500	2,330/2,450
Running Current	Cooling/Heating	A	10.7/10.7	10.8/11.2	10.4/11.0
Power Supply	ø, V, Hz		1, 220-240, 50	1, 220-240, 50	1, 220-240, 50
Power Factor	%		93	95	93
E.E.R	Cooling	W/W(kcal/hW)	2.93(2.52)	2.93(2.52)	3.02(2.60)
		Btu/hW	10	10	10.3
C.O.P	Heating	W/W(kcal/hW)	3.26(2.80)	3.14(2.76)	3.15(2.71)
		Btu/hW	11.13	10.72	10.77
Setting Temperature Range(cool/heat)		°C	18~30/16~30	18~30/16~30	18~30/16~30
Dehumidification Rate		l/h	3.3	3.3	3.3
Refrigerant Control			Capillary Tube	Capillary Tube	Capillary Tube
Refrigerant Charge		g(oz), type		1,900(67.1), R-410A	

Indoor Unit			ATNH246FLAA, ATNH246FLCA	ABNH246HLAA	AVNH246BLAA
Indoor fan motor	Output	W	40.3	118	35
	Model		OEM-3502P2	IC-13450LG13C	IC-9430LGCE
	No. of Poles		6	4	4
	Input	W	121	180	63
	Running Current	A	0.53	0.92	0.27
Indoor Fan	Capacitor	µF/Vac	4.0/ 440	6/370	1.5/370
	Type		Turbo Fan	Sirocco Fan	Cross Flow Fan
Indoor Fan RPM	No. Used / Diameter	EA/mm(inch)	1/382(15)	2/177(7)	1/80(3.1)
	Cooling(H/M/L)	rpm	600 / 540 / 480	1417/1350/1255	1160/1060/960
Air Circulation	Heating(H/M/L)	rpm	600 / 540 / 480	1417/1350/1255	1160/1060/960
	Indoor (H/M/L)	CMM(CFM)	15/14/13(530/494/459)	18/16.5/14(636/583/494)	15/14/13(530/494/459)
Noise Level (Sound Press,1m)	Indoor(H/M/L)	dB(A)±3	43/41/38	37/35/33	45/42/39
Temperature Controller			Thermistor	Thermistor	Thermistor
Indoor Coil	Tube Size (OD)	inch(mm)	0.275(7)	0.275(7)	0.275(7)
	Fins per inch		21	21	20
	No. of Rows & Column		2R 12C	3R 10C	2R 14C
Dimensions (W*D*H)	Indoor	inch(mm)	29.3*29.4*11.5(744*744*292)	34.6*10.2*17.7 (880*260*450)	47.2*24.21*8.07(1200*615*205)
	Panel	inch(mm)	33.5*33.5*1.18(850*850*30)	-	-
Net Weight	Indoor	kg(lbs)	26(57.3)	28(61.7)	22(48.5)

Outdoor Unit			AUUH246A/AB		
Compressor	Locked Rotor Amp.	A	62		
	Type		Rotary		
	Quantity	No.	1		
	Model		GP290P		
	Maker		LG		
	Capacity	W(Btu/h)	6,250(24,800)		
	Motor Type		PSC		
	Motor Input	W	2505		
	Oil Type		FVC68D		
	Oil Charge	cc	1130		
Outdoor Coil	O.L.P Type(Model Name)		Internal		
	Tube Size (OD)	inch(mm)	0.275(7)		
	Fins per inch		18		
Outdoor fan motor	No. of Rows & Column		2R 36C		
	Output	W	67.2		
	Model		IC-28640LG28P		
	No. of Poles		6		
	Input	W	120		
Outdoor Fan	Running Current	A	0.54		
	Capacitor	µF/Vac	6 / 370		
	Type		Propeller		
	No. Used / Diameter	EA/inch(mm)	1/18.1(460)		
	Discharge	Side / Top	Side Discharge		
Air Circulation	Outdoor	CMM(CFM)	58(2048)		
Noise Level (Sound Press,1m)	Outdoor	dB(A)±3	52		
SVC Valve	Liquid	inch(mm)	1 / 4 (6.35)		
	Gas		5 / 8 (15.88)		
Dimensions (W*H*D)	Outdoor	inch(mm)	34.2*31.5*12.6(870*800*320)		
Net Weight	Outdoor	kg(lbs)	60(132.2)		

Others			
Power Supply Cable(With Earth Cable)	No.* mm <sup>2</sup>	3 * 2.5	
Conneccting Cable(With Earth Cable)		5 * 0.75	
Connecting Tube (ø. Socket Flare)	Liquid Side	inch(mm)	1 / 4 (6.35)
	Gas Side	inch(mm)	5 / 8 (15.88)
	Length, std	m	7.5
	Max length/elevation	m	50/30
	Drain hose (ID ø)	Indoor Unit	mm
Outdoor Unit		mm	ø32

- Notes:**
- Capacities are based on the following conditions:  
 Cooling: - Indoor Temperature 27°C(80.6°F) DB /19°C(66.2°F)WB  
 - Outdoor Temperature 35°C(95°F) DB /24°C(75.2°F)WB  
 - Interconnecting Piping Length 7.5m  
 - Level Difference of Zero.  
 Heating:- Indoor Temperature 20°C(68°F) DB / 15°C(59°F) WB  
 - Outdoor Temperature 7°C(44.6°F) DB / 6°C(42.8°F) WB  
 - Interconnecting Piping Length 7.5 m  
 - Level Difference of Zero.
  - Capacities are Net Capacities.
  - Due to our policy of innovation some specifications may be changed without notification.

Nominal 2.5 Ton

Heat Pump

System	Indoor Unit		ATNH306FLAA, ATNH306FLCA	ABNH306GLAA	AVNH306BLAA
	Outdoor Unit		AUUH306A/AB		
	Decoration Panel		PT-HFA,PT-HFC	-	-
Cooling Capacity	W(kcal/h)		7,913(6,804)	8,411(7,232)	7,678(6,602)
	Btu/h		27000	28700	26200
Heating Capacity	W(kcal/h)		8,704(7,484)	9,232(7,938)	8,382(7,207)
	Btu/h		29700	31500	28600
Input	Cooling/Heating	W	2,790/2,900	2,950/2,600	2,720/2,970
Running Current	Cooling/Heating	A	13.0/13.7	13.5/12.1	12.7/13.8
Power Supply	ø, V, Hz		1, 220-240, 50	1, 220-240, 50	1, 220-240, 50
Power Factor	%		93	94	93
E.E.R	Cooling	W/W(kcal/hW)	2.83(2.44)	2.85(2.45)	2.82(2.42)
		Btu/hW	9.67	9.72	9.63
C.O.P	Heating	W/W(kcal/hW)	3.0(2.58)	3.55(3.05)	2.86(2.46)
		Btu/hW	10.24	12.11	9.76
Setting Temperature Range(cool/heat)	°C		18-30/16-30	18-30/16-30	18-30/16-30
Dehumidification Rate	l/h		3.5	3.5	3.5
Refrigerant Control			Capillary Tube	Capillary Tube	Capillary Tube
Refrigerant Charge	g(oz), type			2,300(81.2), R-410A	

Indoor Unit			ATNH306FLAA, ATNH306FLCA	ABNH306GLAA	AVNH306BLAA
Indoor fan motor	Output	W	-	124	-
	Model		OBM-4015P2	IC-13450LG13J	IC-9430LGCL
	No. of Poles		6	4	4
	Input	W	146	300	81
	Running Current	A	0.67	1.34	0.36
Indoor Fan	Capacitor	µF/Vac	4/440	6/370	1.5/ 370
	Type		Turbo Fan	Sirocco Fan	Cross Flow Fan
Indoor Fan RPM	No. Used / Diameter	EA/mm(inch)	1/382(15)	2/177(7)	80(3.1)
	Cooling(H/M/L)	rpm	650 / 600 / 550	1415/1359/1290	1160/1060/960
Air Circulation	Heating(H/M/L)	rpm	650 / 600 / 550	1415/1359/1290	1160/1060/960
	Indoor (H/M/L)	CMM(CFM)	19/17/15(67/1/600/530)	26.5/23/20(936/812/706)	18/16/14(636/564/494)
Noise Level (Sound Press, 1m)	Indoor(H/M/L)	dB(A)±3	45/42/39	42/40/38	45/42/39
Temperature Controller			Thermistor	Thermistor	Thermistor
Indoor Coil	Tube Size (OD)	inch(mm)	0.275(7)	0.275(7)	0.275(7)
	Fins per inch		21	21	20
	No. of Rows & Column		2R 12C	3R 12C	2R 14C
Dimensions (W*D*H)	Indoor	inch(mm)	29.3*29.4*11.5(744*744*292)	46.4*11.7 *17.71(1180*298*450)	47.24*24.21*8.07 (1200*615*205)
	Panel	inch(mm)	33.5*33.5*1.18(850*850*30)	-	-
Net Weight	Indoor	kg(lbs)	26(57.3)	38(83.8)	22(48.5)

Outdoor Unit			AUUH306A/AB		
Compressor	Locked Rotor Amp.	A	68		
	Type		Rotary		
	Quantity	No.	1		
	Model		5JS330D		
	Maker		MATSUSHITA		
	Capacity	W(Btu/h)	8,235(28,097)		
	Motor Type		PSC		
	Motor Input	W	2915		
	Oil Type		FV50S		
	Oil Charge	cc	1130		
Outdoor Coil	O.L.P Type(Model Name)		Internal		
	Tube Size (OD)	inch(mm)	0.275(7)		
	Fins per inch		18		
Outdoor fan motor	No. of Rows & Column		2R 36C		
	Output	W	67.2		
Outdoor Fan	Model		IC-28640LG28P		
	No. of Poles		6		
	Input	W	120		
	Running Current	A	0.54		
	Capacitor	µF/Vac	6 / 370		
Outdoor Fan	Type		Propeller		
	No. Used / Diameter	EA/inch(mm)	1/18.1(460)		
	Discharge	Side / Top	Side Discharge		
	Speed	rpm	850		
Air Circulation	Outdoor	CMM(CFM)	58(2048)		
Noise Level (Sound Press, 1m)	Outdoor	dB(A)±3	54		
SVC Valve	Liquid	inch(mm)	1 / 4 (6.35)		
	Gas		5 / 8 (15.88)		
Dimensions (W*H*D)	Outdoor	inch(mm)	34.2*31.5*12.6(870*800*320)		
Net Weight	Outdoor	kg(lbs)	62(136.6)		

Others			
Power Supply Cable(With Earth Cable)	No.* mm²		3 * 2.5
Connecting Cable(With Earth Cable)			5 * 0.75
Connecting Tube (ø. Socket Flare)	Liquid Side	inch(mm)	1 / 4 (6.35)
	Gas Side	inch(mm)	5 / 8 (15.88)
	Length, std	m	7.5
	Max length/elevation	m	50/30
Drain hose (ID ø)	Indoor Unit	mm	ø25
	Outdoor Unit	mm	ø32

- Notes:**
- Capacities are based on the following conditions:
    - Cooling: - Indoor Temperature 27°C(80.6°F) DB /19°C(66.2°F)WB
    - Outdoor Temperature 35°C(95°F) DB /24°C(75.2°F) WB
    - Interconnecting Piping Length 7.5m
    - Level Difference of Zero.
  - Capacities are Net Capacities.
  - Due to our policy of innovation some specifications may be changed without notification.
- Heating:- Indoor Temperature 20°C(68°F) DB / 15°C(59°F)WB
- Outdoor Temperature 7°C(44.6°F) DB / 6°C(42.8°F)WB
  - Interconnecting Piping Length 7.5 m
  - Level Difference of Zero.

**Nominal 3 Ton**

**Heat Pump**

System	Indoor Unit		ATNH368DLAA, ATNH368DLCA		ABNH368GLAA	
	Outdoor Unit		AUUH368A/AB			
	Decoration Panel		PT-HDA,PT-HDC		-	
Cooling Capacity	W(kcal/h)		10,550(9,072)		10,550(9,072)	
	Btu/h		36000		36000	
Heating Capacity	W(kcal/h)		11,606(9,979)		11,606(9,979)	
	Btu/h		39600		39600	
Input	Cooling/Heating	W	3760/3340		3850/3330	
Running Current	Cooling/Heating	A	6.5/6.0		6.6/6.0	
Power Supply	ø, V, Hz		3, 380-415, 50		3, 380-415, 50	
Power Factor	%		83		84	
E.E.R	Cooling	W/W(kcal/hW)	2.80(2.41)		2.73(2.35)	
		Btu/hW	9.57		9.35	
C.O.P	Heating	W/W(kcal/hW)	3.47(2.98)		3.48(2.99)	
		Btu/hW	11.85		11.89	
Setting Temperature Range(cool/heat)		°C	18-30/16-30		18-30/16-30	
Dehumidification Rate		l/h	4		4	
Refrigerant Control		Capillary Tube		Capillary Tube		
Refrigerant Charge		g(oz), type	2,200(77.6), R-410A		2,200(77.6), R-410A	

Indoor Unit			ATNH368DLAA, ATNH368DLCA		ABNH368GLAA	
Indoor fan motor	Output	W	52.5		272	
	Model		IC-1630LGPJ		IC-13450LG13A	
	No. of Poles		6		4	
	Input	W	175		323	
	Running Current	A	0.76		1.42	
Indoor Fan	Capacitor	µF/Vac	4 / 450		6/370	
	Type		Turbo Fan		Sirocco Fan	
Indoor Fan RPM	No. Used / Diameter	EA/mm(inch)	1/460(18.1)		-	
	Cooling(H/M/L)	rpm	560 / 520 /480		1415/1359/1290	
Air Circulation	Heating(H/M/L)	rpm	560 / 520 /480		1415/1359/1290	
	Indoor (H/M/L)	CMM(CFM)	25/23/21(883/812/742)		32/29/26.5 (1130/1024/936)	
Noise Level (Sound Press,1m)	Indoor(H/M/L)	dB(A)±3	40/38/36		42/40/38	
Temperature Controller	Tube Size (OD)	inch(mm)	Thermistor		Thermistor	
	Fins per inch		0.275(7)		0.275(7)	
Indoor Coil	No. of Rows & Column		21		21	
			2R 12C		3R12C	
Dimensions (W*D*H)	Indoor	inch(mm)	33.0*33.0*11.3(840*840*288)		46.4*11.7 *17.71 (1180*298*450)	
	Panel	inch(mm)	37.4*37.4*1.2(950*950*30)		-	
Net Weight	Indoor	kg(lbs)	33(72.7)		38(83.8)	

Outdoor Unit			AUUH368A/AB	
Compressor	Locked Rotor Amp.	A	47	
	Type		Scroll	
	Quantity	No.	1	
	Model		AQ042YA	
	Maker		LG	
	Capacity	W(Btu/h)	10,258(35,000)	
	Motor Type		Condenser Inducted	
	Motor Input	W	3608	
	Oil Type		FVC68ST	
	Oil Charge	cc	1200	
Outdoor Coil	O.L.P Type(Model Name)		Internal	
	Tube Size (OD)	inch(mm)	0.275(7)	
	Fins per inch		18	
Outdoor fan motor	No. of Rows & Column		2R 48C	
	Output	W	41	
	Model		IC-9625LGSY	
	No. of Poles		6	
	Input	W	80	
Outdoor Fan	Running Current	A	0.35	
	Capacitor	µF/Vac	2 / 370	
	Type		Propeller	
	No. Used / Diameter	EA/inch(mm)	2 /15.7(400)	
	Discharge	Side / Top	Side Discharge	
Air Circulation	Outdoor	rpm	880	
Noise Level (Sound Press,1m)	Outdoor	CMM(CFM)	105(3708)	
SVC Valve	Liquid	inch(mm)	1 / 4 (6.35)	
Dimensions (W*H*D)	Gas	inch(mm)	5 / 8 (15.88)	
	Outdoor	inch(mm)	35.3*41.7*12.6(870*1060*320)	
Net Weight	Outdoor	kg(lbs)	85(187.3)	

Others			
Power Supply Cable(With Earth Cable)	No.* mm <sup>2</sup>	5 * 3.5	
Conneccting Cable(With Earth Cable)		5 * 1.25	
Connecting Tube (ø. Socket Flare)	Liquid Side	inch(mm)	1 / 4 (6.35)
	Gas Side	inch(mm)	5 / 8 (15.88)
	Length, std	m	7.5
	Max length/elevation	m	50/30
Drain hose (ID ø)	Indoor Unit	mm	ø25
	Outdoor Unit	mm	ø32

- Notes:**
- Capacities are based on the following conditions:  
 Cooling: - Indoor Temperature 27°C(80.6°F) DB /19°C(66.2°F)WB  
 - Outdoor Temperature 35°C(95°F) DB /24°C(75.2°F) WB  
 - Interconnecting Piping Length 7.5m  
 - Level Difference of Zero.  
 Heating:- Indoor Temperature 20°C(68°F) DB / 15°C(59°F) WB  
 - Outdoor Temperature 7°C(44.6°F) DB / 6°C(42.8°F) WB  
 - Interconnecting Piping Length 7.5 m  
 - Level Difference of Zero.
  - Capacities are Net Capacities.
  - Due to our policy of innovation some specifications may be changed without notification.

Nominal 4 Ton

Heat Pump

System	Indoor Unit		ATNH488DLAA, ATNH488DLCA		ABNH488ELAA	
	Outdoor Unit		AUUH488A/AB			
	Decoration Panel		PT-HDA,PT-HDC			
Cooling Capacity	W(kcal/h)		14,068(12,096)		14,068(12,096)	
	Btu/h		48000		48000	
Heating Capacity	W(kcal/h)		15,474(13,306)		15,474(13,306)	
	Btu/h		52800		52800	
Input	Cooling/Heating	W	5300/5050		5780/4980	
Running Current	Cooling/Heating	A	9.3/9.0		9.9/9.0	
Power Supply	ø, V, Hz		3, 380-415, 50		3, 380-415, 50	
Power Factor	%		82		84	
E.E.R	Cooling	W/W(kcal/hW)	2.65(2.28)		2.43(2.09)	
		Btu/hW	9.05		8.30	
C.O.P	Heating	W/W(kcal/hW)	3.06(2.63)		3.10(2.67)	
		Btu/hW	10.45		10.60	
Setting Temperature Range(cool/heat)		°C	18-30/16-30		18-30/16-30	
Dehumidification Rate		l/h	5.5		5.5	
Refrigerant Control			Capillary Tube		Capillary Tube	
Refrigerant Charge		g(oz), type	4,050(142.8), R-410A		4,050(142.8), R-410A	

Indoor Unit			ATNH488DLAA, ATNH488DLCA		ABNH488ELAA	
Indoor fan motor	Output	W	58.5		391	
	Model		IC-1640L GPH		808555AVA-A12EX	
	No. of Poles		6		4	
	Input	W	195		662	
	Running Current	A	1.5		2.92	
Indoor Fan	Capacitor	µF/Vac	6 / 400		12 / 450	
	Type		Turbo Fan		Sirocco Fan	
Indoor Fan RPM	No. Used / Diameter	EA/mm(inch)	1/460(18.1)		-	
	Cooling(H/M/L)	rpm	600 / 555 / 520		1085/1024/970	
Air Circulation	Heating(H/M/L)	rpm	600 / 555 / 520		1085/1024/970	
	Indoor (H/M/L)	CMM(CFM)	30/28/26(1059/988/918)		40/36/30(1413/1271/1059)	
Noise Level (Sound Press, 1m)	Indoor(H/M/L)	dB(A)±3	43/41/39		44/42/40	
Temperature Controller	Tube Size (OD)	inch(mm)	Thermistor		Thermistor	
	Fins per inch		0.275(7)		0.375(9.52)	
Indoor Coil	No. of Rows & Column		21		17	
			2R 12C		3R14C	
Dimensions (W*D*H)	Indoor	inch(mm)	33.0*33.0*11.3(840*840*288)		48.43*14.57*26.77(1230*370*680)	
	Panel	inch(mm)	37.4*37.4*1.2(950*950*30)		-	
Net Weight	Indoor	kg(lbs)	33(72.7)		68(149.9)	

Outdoor Unit			AUUH488A/AB	
Compressor	Locked Rotor Amp.	A	63	
	Type		Scroll	
	Quantity	No.	1	
	Model		AR061YA	
	Maker		LG	
	Capacity	W(Btu/h)	14,888(50,800)	
	Motor Type		Condenser Inducted	
	Motor Input	W	5347	
	Oil Type		FVC68ST	
	Oil Charge	cc	1800	
Outdoor Coil	O.L.P Type(Model Name)		Internal	
	Tube Size (OD)	inch(mm)	0.375(9.52)	
	Fins per inch		18	
Outdoor fan motor	No. of Rows & Column		2R 44C	
	Output	W	72	
Outdoor Fan	Model		OBM-4006P2	
	No. of Poles		6	
	Input	W	151	
	Running Current	A	0.63	
	Capacitor	µF/Vac	6 / 370	
Air Circulation	Type		Propeller	
	No. Used / Diameter	EA/inch(mm)	2/18.1(460)	
	Discharge	Side / Top	Side Discharge	
	Speed	rpm	880	
Noise Level (Sound Press, 1m)	Outdoor	dB(A)±3	56	
SVC Valve	Liquid	inch(mm)	3 / 8 (9.52)	
	Gas		3 / 4 (19.05)	
Dimensions (W*H*D)	Outdoor	inch(mm)	35.4*48.2*14.6(900*1225*370)	
Net Weight	Outdoor	kg(lbs)	93 (205.0)	

Others			
Power Supply Cable(With Earth Cable)	No.* mm²	5 * 3.5	
Connecting Cable(With Earth Cable)		5 * 1.25	
Connecting Tube (ø. Socket Flare)	Liquid Side	inch(mm)	3 / 8 (9.52)
	Gas Side	inch(mm)	3 / 4 (19.05)
	Length, std	m	7.5
	Max length/elevation	m	50/30
Drain hose (ID ø)	Indoor Unit	mm	ø25
	Outdoor Unit	mm	ø32

- Notes:**
- Capacities are based on the following conditions:  
 Cooling: - Indoor Temperature 27°C(80.6°F) DB /19°C(66.2°F)WB  
 - Outdoor Temperature 35 °C(95°F) DB /24°C(75.2°F) WB  
 - Interconnecting Piping Length 7.5m  
 - Level Difference of Zero.  
 Heating:- Indoor Temperature 20°C(68°F) DB / 15°C(59°F) WB  
 - Outdoor Temperature 7°C(44.6°F) DB / 6°C(42.8°F) WB  
 - Interconnecting Piping Length 7.5 m  
 - Level Difference of Zero.
  - Capacities are Net Capacities.
  - Due to our policy of innovation some specifications may be changed without notification.

Nominal 5 Ton

Heat Pump

System	Indoor Unit		ATNH608DLAA, ATNH608DLCA		ABNH608ELAA	
	Outdoor Unit		AUUH608A/AB			
	Decoration Panel		PT-HDA,PT-HDC		-	
Cooling Capacity	W(kcal/h)		15,533(13,356)		16,999(14,616)	
	Btu/h		53000		58000	
Heating Capacity	W(kcal/h)		16,559(14,239)		17,731(15,246)	
	Btu/h		56500		60500	
Input	Cooling/Heating	W	6,450/5,060		7,060(5,280)	
Running Current	Cooling/Heating	A	10.8/8.7		11.4/8.9	
Power Supply		ø, V, Hz	3, 380-415, 50		3, 380-415, 50	
Power Factor		%	88		89	
E.E.R	Cooling	W/W(kcal/hW)	2.40(2.07)		2.40(2.07)	
		Btu/hW	8.22		8.21	
C.O.P	Heating	W/W(kcal/hW)	3.27(2.81)		3.35(2.88)	
		Btu/hW	11.16		11.45	
Setting Temperature Range(cool/heat)		°C	18-30/16-30		18-30/16-30	
Dehumidification Rate		l/h	6.5		6.5	
Refrigerant Control			Capillary Tube		Capillary Tube	
Refrigerant Charge		g(oz), type	5,200(183.4), R-410A			

Indoor Unit			ATNH608DLAA, ATNH608DLCA		ABNH608ELAA	
Indoor fan motor	Output	W	107		389	
	Model		IC-14640L GPM		808555PVA-A18EX	
	No. of Poles		6		4	
	Input	W	237		670	
	Running Current	A	1.8		2.9	
	Capacitor	µF/Vac	6 / 400		15 / 450	
Indoor Fan	Type		Turbo Fan		Sirocco Fan	
	No. Used / Diameter	EA/mm(inch)	1/460(18.1)		-	
Indoor Fan RPM	Cooling(H/M/L)	rpm	700 / 650 / 600		1260/1196/1125/1052	
	Heating(H/M/L)	rpm	700 / 650 / 600		1260/1196/1125/1052	
Air Circulation	Indoor (H/M/L)	CMM(CFM)	34/32/30(1200/1130/1059)		49/45/40/35(1730/1589/1413/1236)	
Noise Level (Sound Press,1m)	Indoor(H/M/L)	dB(A)±3	50/47/43		49/46/44/42	
Temperature Controller			Thermistor		Thermistor	
Indoor Coil	Tube Size (OD)	inch(mm)	0.275(7)		0.375(9.52)	
	Fins per inch		21		19	
	No. of Rows & Column		2R 12C		4R14C	
Dimensions (W*D*H)	Indoor	inch(mm)	33.0*33.0*11.3(840*840*288)		48.43*14.57*26.77(1230*370*680)	
	Panel	inch(mm)	37.4*37.4*1.2(950*950*30)		-	
Net Weight	Indoor	kg(lbs)	33(72.7)		70(154.3)	

Outdoor Unit			AUUH608A/AB	
Compressor	Locked Rotor Amp.	A	81	
	Type		Reciprocating	
	Quantity	No.	1	
	Model		H89A723DBVA	
	Maker		Bristol	
	Capacity	W(Btu/h)	17,740(60,529)	
	Motor Type		Condenser Inducted	
	Motor Input	W	5717	
	Oil Type		Mobil EAL Arctic 32 BC(POE)	
	Oil Charge	cc	1922	
Outdoor Coil	O.L.P Type(Model Name)		Internal	
	Tube Size (OD)	inch(mm)	0.375(9.52)	
	Fins per inch		18	
Outdoor fan motor	No. of Rows & Column		2R 44C	
	Output	W	72	
Outdoor Fan	Model		OBM-4006P2	
	No. of Poles		6	
	Input	W	151	
	Running Current	A	0.63	
	Capacitor	µF/Vac	6 / 370	
Outdoor Fan	Type		Propeller	
	No. Used / Diameter	EA/inch(mm)	2/18.1(460)	
	Discharge	Side / Top	Side Discharge	
	Speed	rpm	880	
Air Circulation	Outdoor	CMM(CFM)	105(3708)	
Noise Level (Sound Press,1m)	Outdoor	dB(A)±3	58	
SVC Valve	Liquid	inch(mm)	1 / 2 (12.7)	
	Gas		3 / 4 (19.05)	
Dimensions (W*H*D)	Outdoor	inch(mm)	35.4*48.2*14.6(900*1225*370)	
Net Weight	Outdoor	kg(lbs)	95(209.4)	

Others			
Power Supply Cable(With Earth Cable)		No.* mm <sup>2</sup>	5 * 3.5
Conncocting Cable(With Earth Cable)			5 * 1.25
Connecting Tube (ø. Socket Flare)	Liquid Side	inch(mm)	1 / 2 (12.7)
	Gas Side	inch(mm)	3 / 4 (19.05)
	Length, std	m	7.5
	Max length/elevation	m	50/30
Drain hose (ID ø)	Indoor Unit	mm	ø25
	Outdoor Unit	mm	ø32

- Notes:**
- Capacities are based on the following conditions:  
 Cooling: - Indoor Temperature 27°C(80.6°F) DB /19°C(66.2°F)WB  
 - Outdoor Temperature 35°C(95°F) DB /24°C(75.2°F) WB  
 - Interconnecting Piping Length 7.5m  
 - Level Difference of Zero.  
 Heating:- Indoor Temperature 20°C(68°F) DB / 15°C(59°F) WB  
 - Outdoor Temperature 7°C(44.6°F) DB / 6°C(42.8°F) WB  
 - Interconnecting Piping Length 7.5 m  
 - Level Difference of Zero.
  - Capacities are Net Capacities.
  - Due to our policy of innovation some specifications may be changed without notification.



# Dimensional Drawings

## 1. Indoor Units

### Ceiling Cassette Type

#### ATNC-EL, ATNH-EL

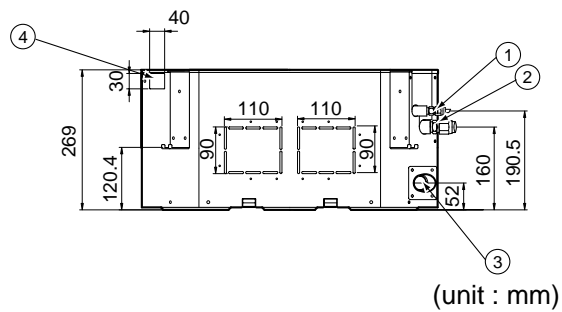
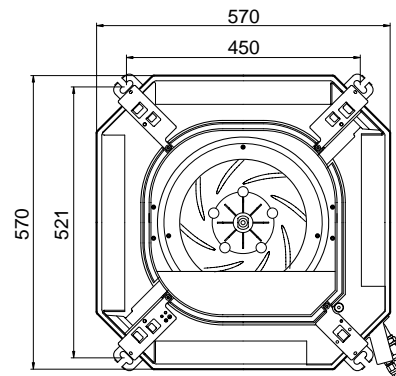
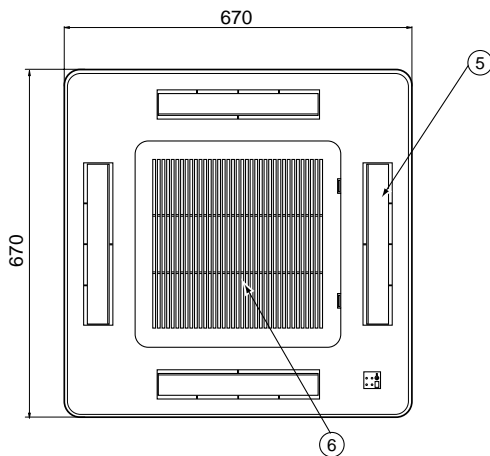
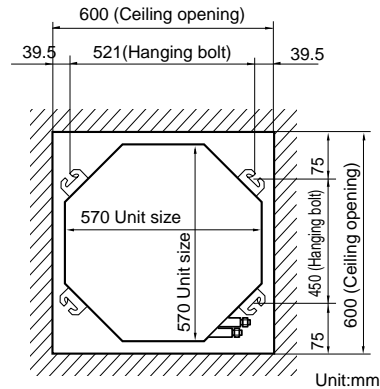
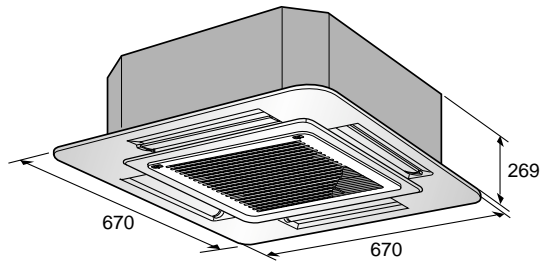

Number	Name	Description
1	Liquid pipe connection	Ø6.35 flare
2	Gas pipe connection	Ø15.88 flare
3	Drain pipe connection	
4	Power supply connection	
5	Air discharge grill	
6	Air suction grill	

**Ceiling Cassette Type**

**ATNC-FL, ATNH-FL**

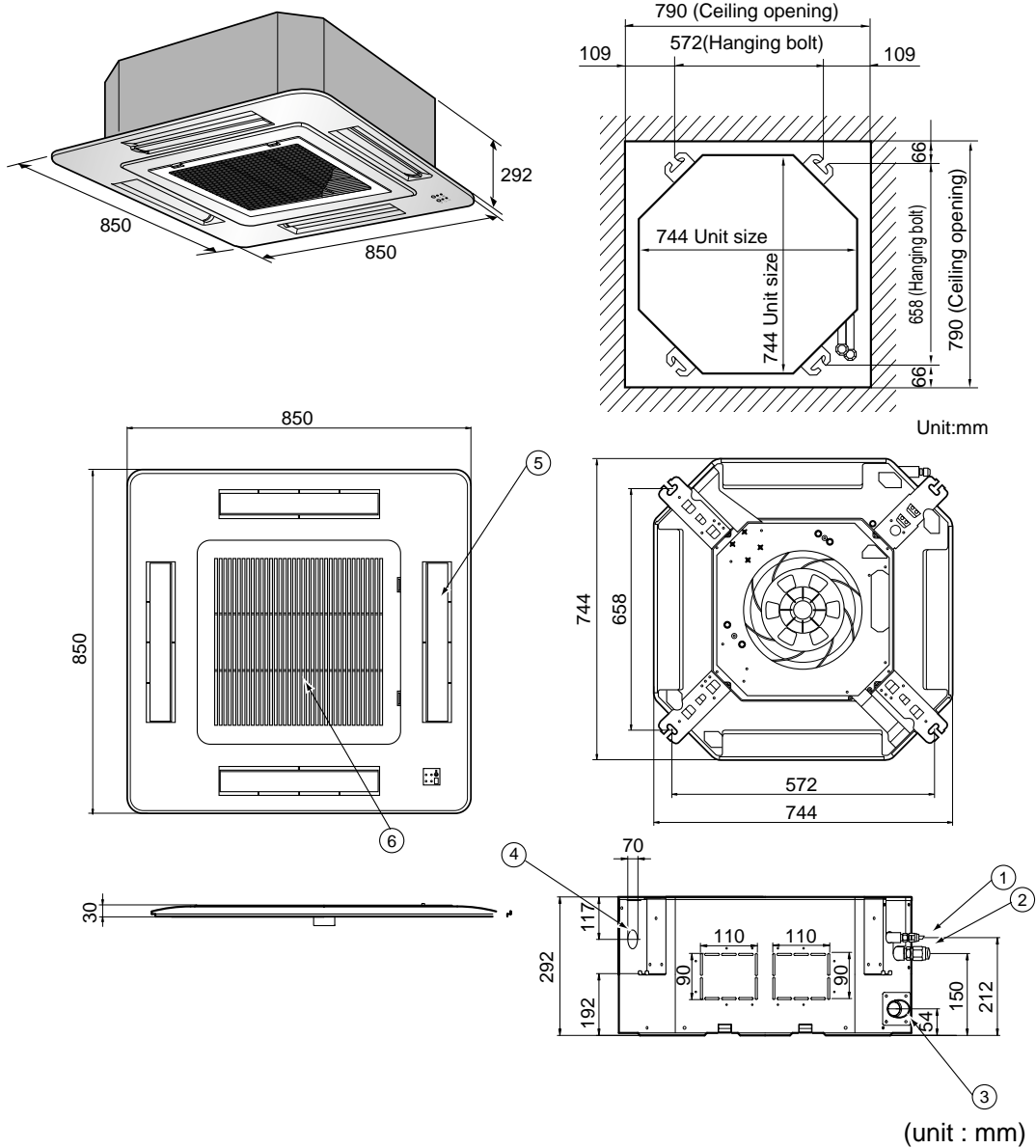

Number	Name	Description
1	Liquid pipe connection	Ø6.35 flare
2	Gas pipe connection	Ø15.88 flare
3	Drain pipe connection	
4	Power supply connection	
5	Air discharge grill	
6	Air suction grill	

**Ceiling Cassette Type**

**ATNC-DL, ATNH-DL**

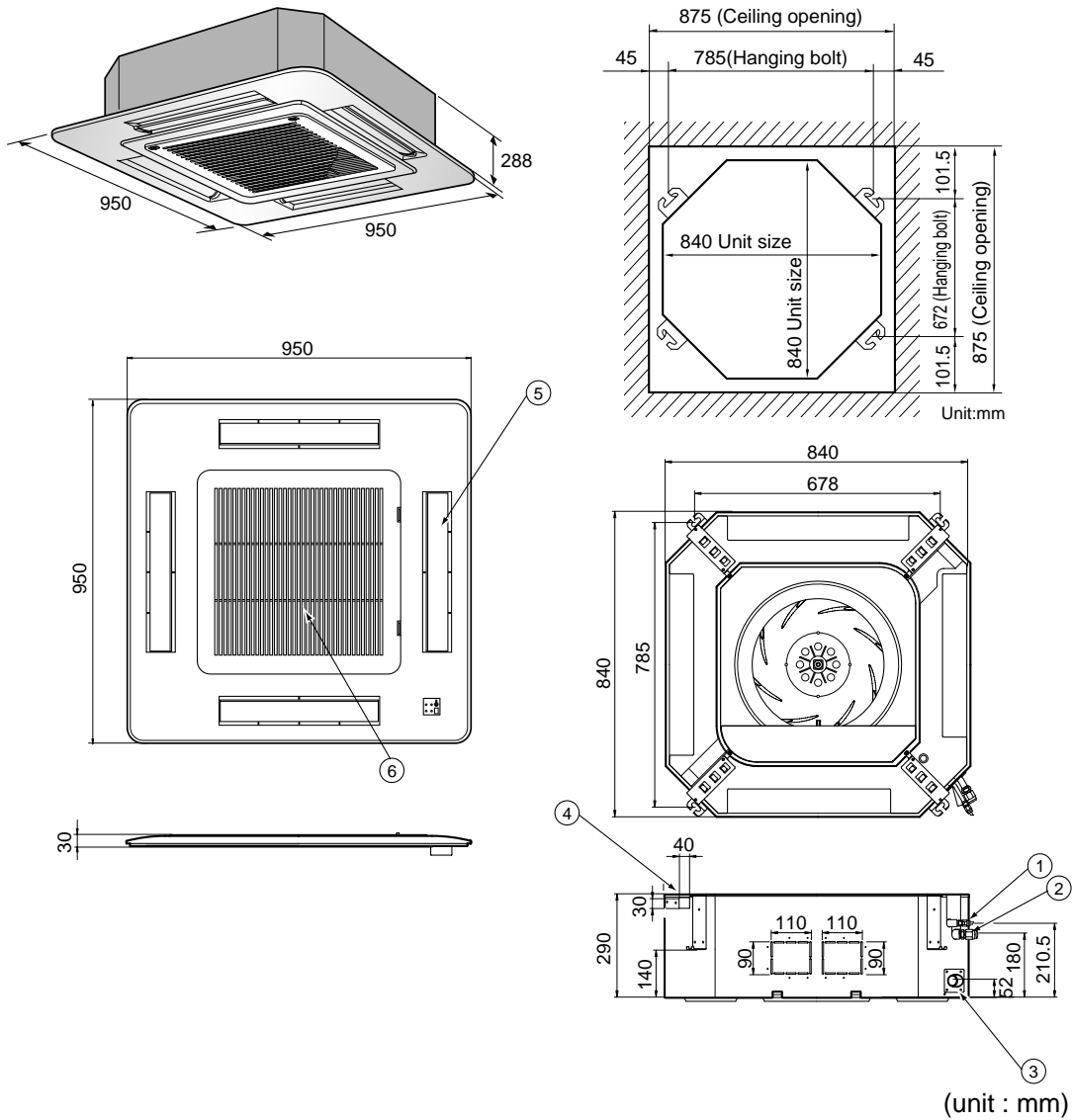

Number	Name	Description
1	Liquid pipe connection	36k: Ø6.35 flare, 48k: Ø9.52 flare, 60k: Ø12.7 flare
2	Gas pipe connection	36k: Ø15.88 flare, 48k/60k: Ø19.05 flare
3	Drain pipe connection	
4	Power supply connection	
5	Air discharge grill	
6	Air suction grill	

**Ceiling Concealed Duct Type**

**ABNC-HL, ABNC-GL, ABNC-EL  
ABNH-HL, ABNH-GL, ABNH-EL**

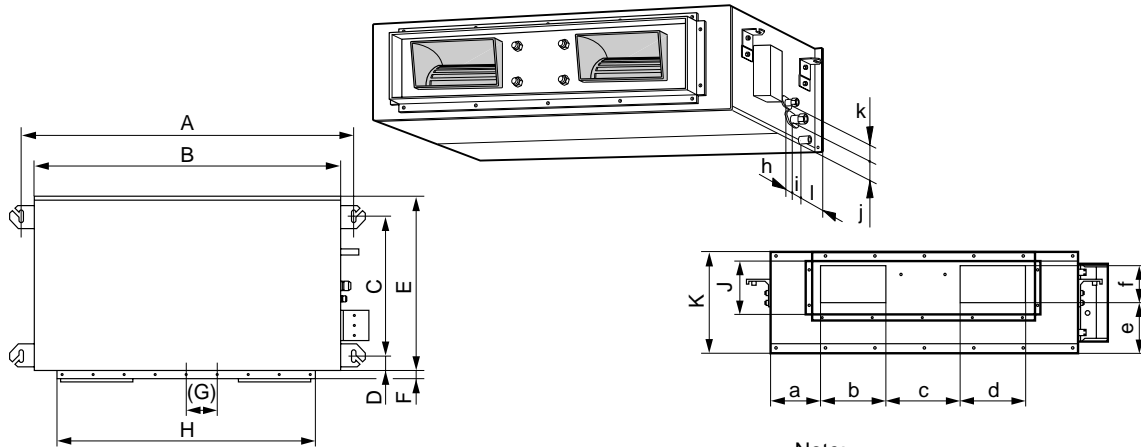

Note:  
1. Pipe Specification(mm)

Model	Liquid	Gas
18k/24k/30k/36k	Ø 6.35	Ø 15.88
48k	Ø 9.52	Ø 19.05
60k	Ø 12.7	Ø 19.05

(Unit: mm)

Capacity		A	B	C	D	E	F	(G)	H	J	K	a	b	c	d	e	f	h	i	j	k	l
18K/24K	ABNC-HL ABNH-HL	932	882	355	45.5	450	30	87	750	163	260	61.5	243	212.3	243	110	130	52	66	81	30	158.5
30K/36K	ABNC-GL ABNH-GL	1232	1182	355	45.5	450	30	87	830	186	298	229.5	243	232	243	116	160	53	59	81	19	158.5
48K/60K	ABNC-EL ABNH-EL	1292	1230	570.5	54	680	30	120	1006	294	370	253.5	253	217	253	152	186	42	143	82	50	172

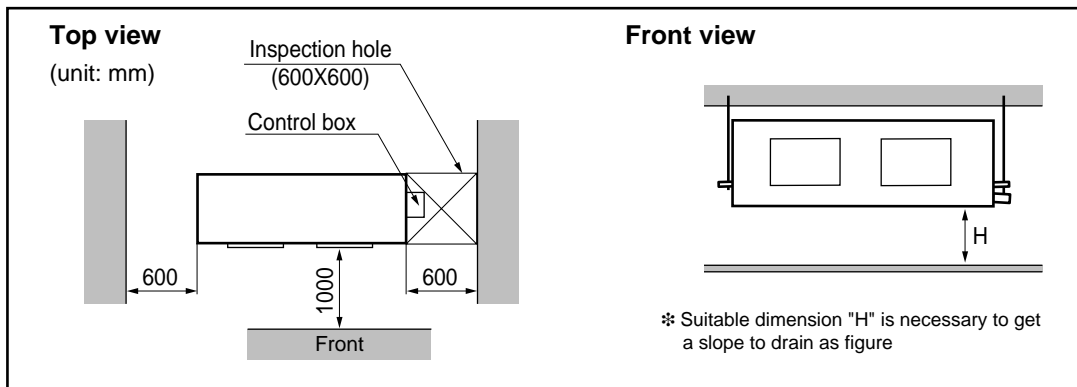

Ceiling & Floor Type

AVNC-BL, AVNH-BL

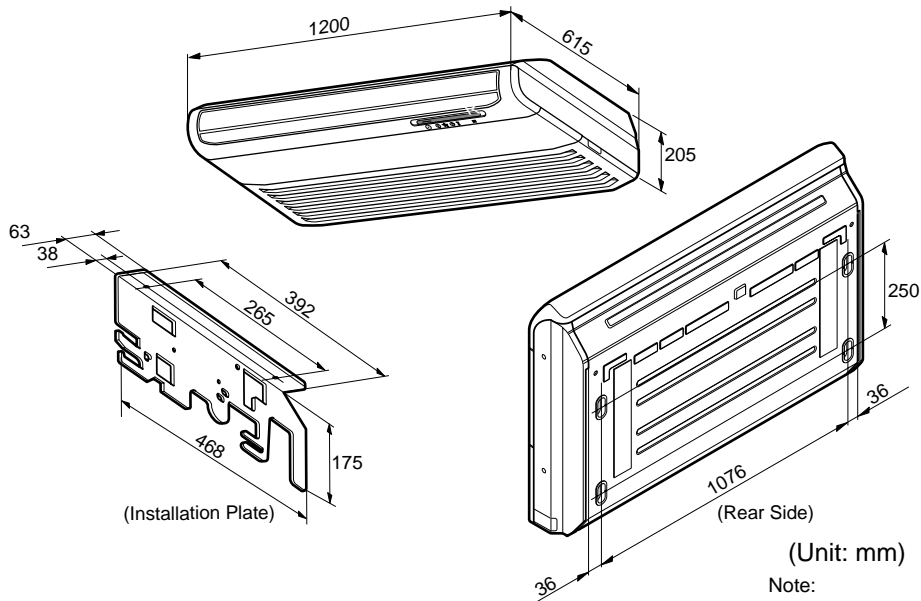

(Unit: mm)

Note:

1. Pipe Specification(mm)

Model	Liquid	Gas
18k/24k/30k	Ø 6.35	Ø 15.88

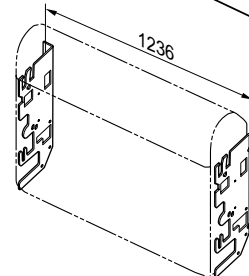
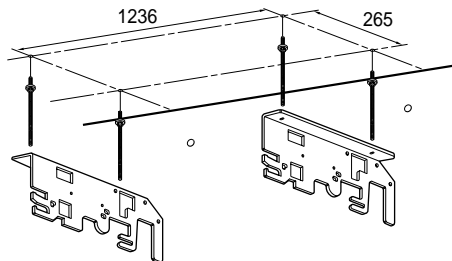
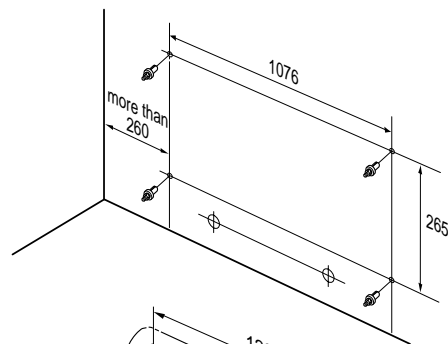
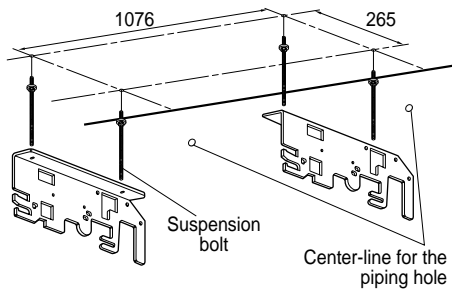
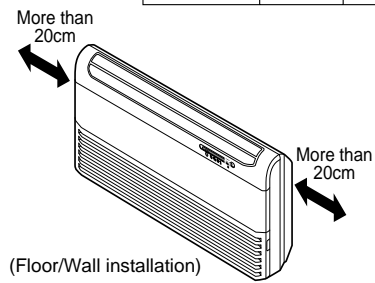
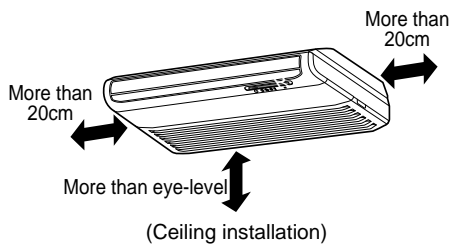

## 2. Outdoor Units

**Model No.: AUUC186A/AB**

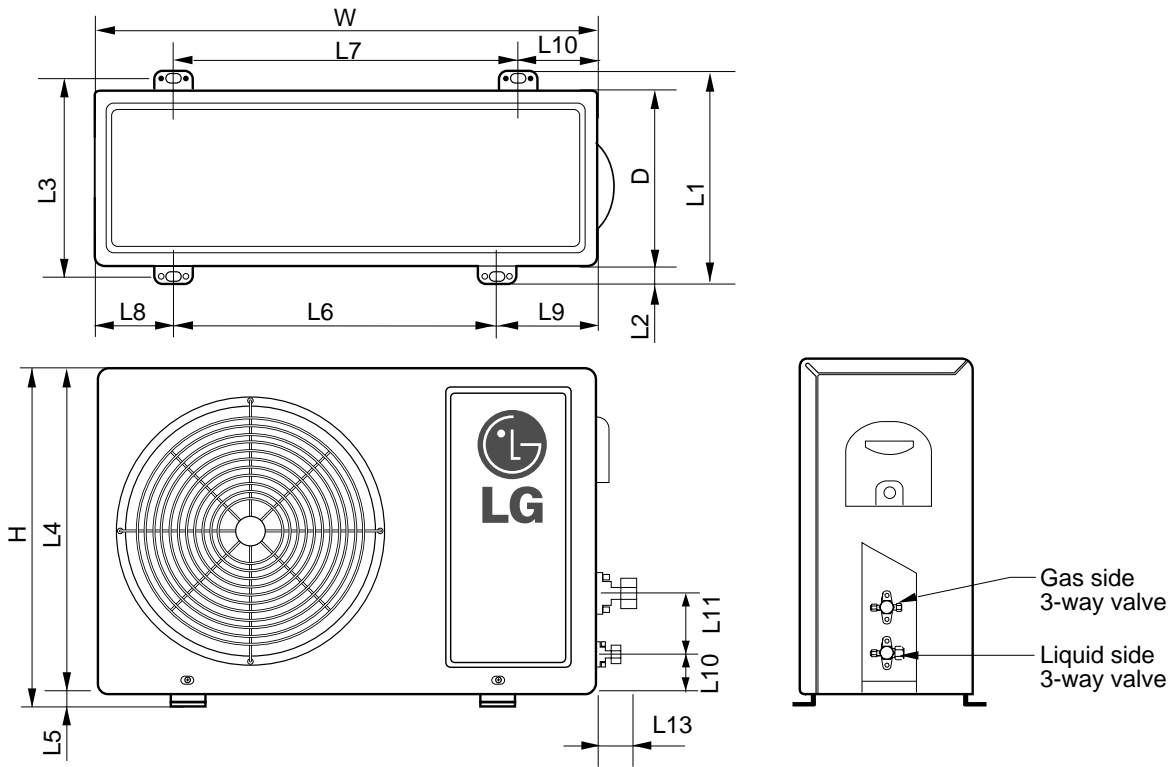

Model No.		AUUC186A/AB
Dim		
W	mm	840
H	mm	575
D	mm	275
L1	mm	305
L2	mm	31
L3	mm	317
L4	mm	558
L5	mm	17
L6	mm	610
L7	mm	640
L8	mm	55
L9	mm	175
L10	mm	145
L11	mm	70
L12	mm	63
L13	mm	54

**Model No.: AUUH186A/AB, AUUC246A/AB**

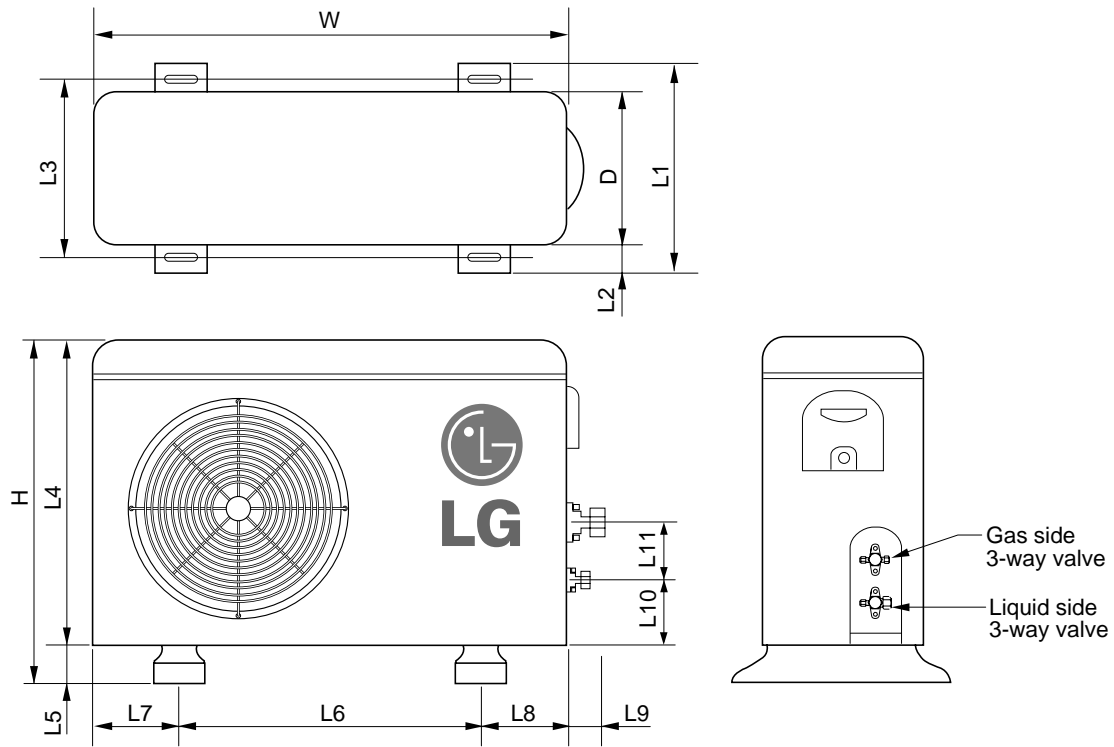

Model No.		AUUH186A/AB, AUUC246A/AB
Dim		
W	mm	870
H	mm	655
D	mm	320
L1	mm	370
L2	mm	25
L3	mm	340
L4	mm	630
L5	mm	25
L6	mm	546
L7	mm	162
L8	mm	162
L9	mm	54
L10	mm	74.5
L11	mm	79

**Model No.: AUUH246A/AB, AUUC306A/AB, AUUH306A/AB**

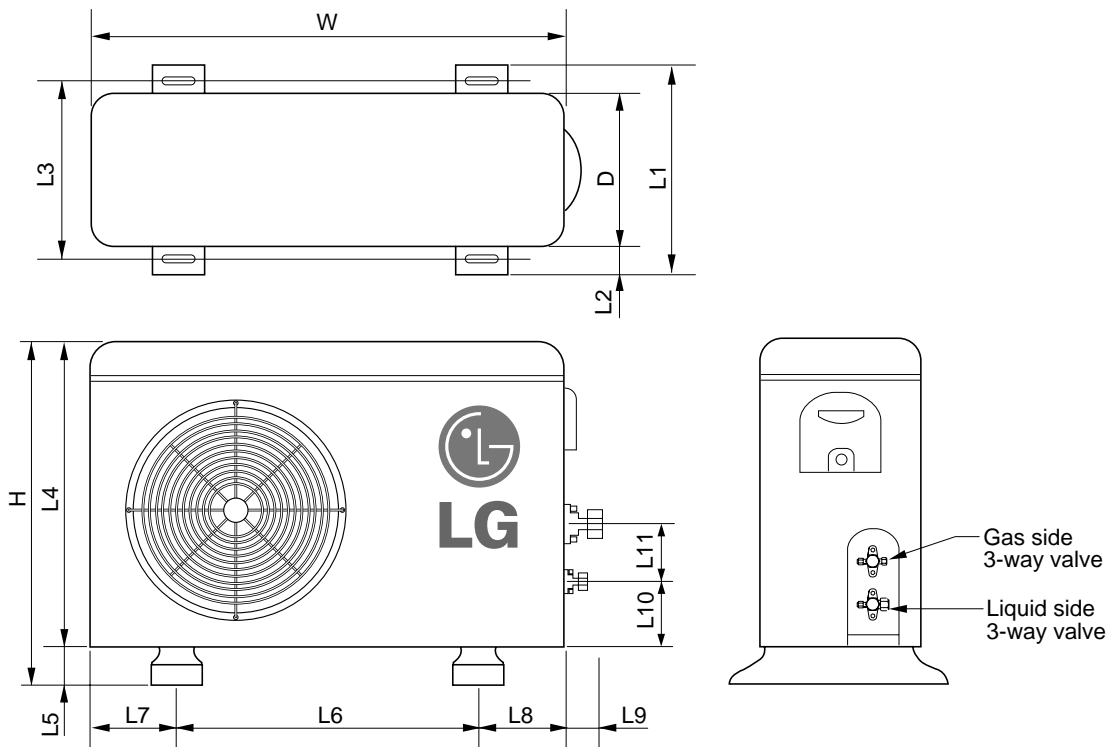

Model No.		AUUH246A/AB, AUUC306A/AB, AUUH306A/AB
W	mm	870
H	mm	800
D	mm	320
L1	mm	370
L2	mm	25
L3	mm	340
L4	mm	775
L5	mm	25
L6	mm	546
L7	mm	162
L8	mm	162
L9	mm	54
L10	mm	74.5
L11	mm	79



**Model No.: AUUC368A/AB, AUUH368A/AB**

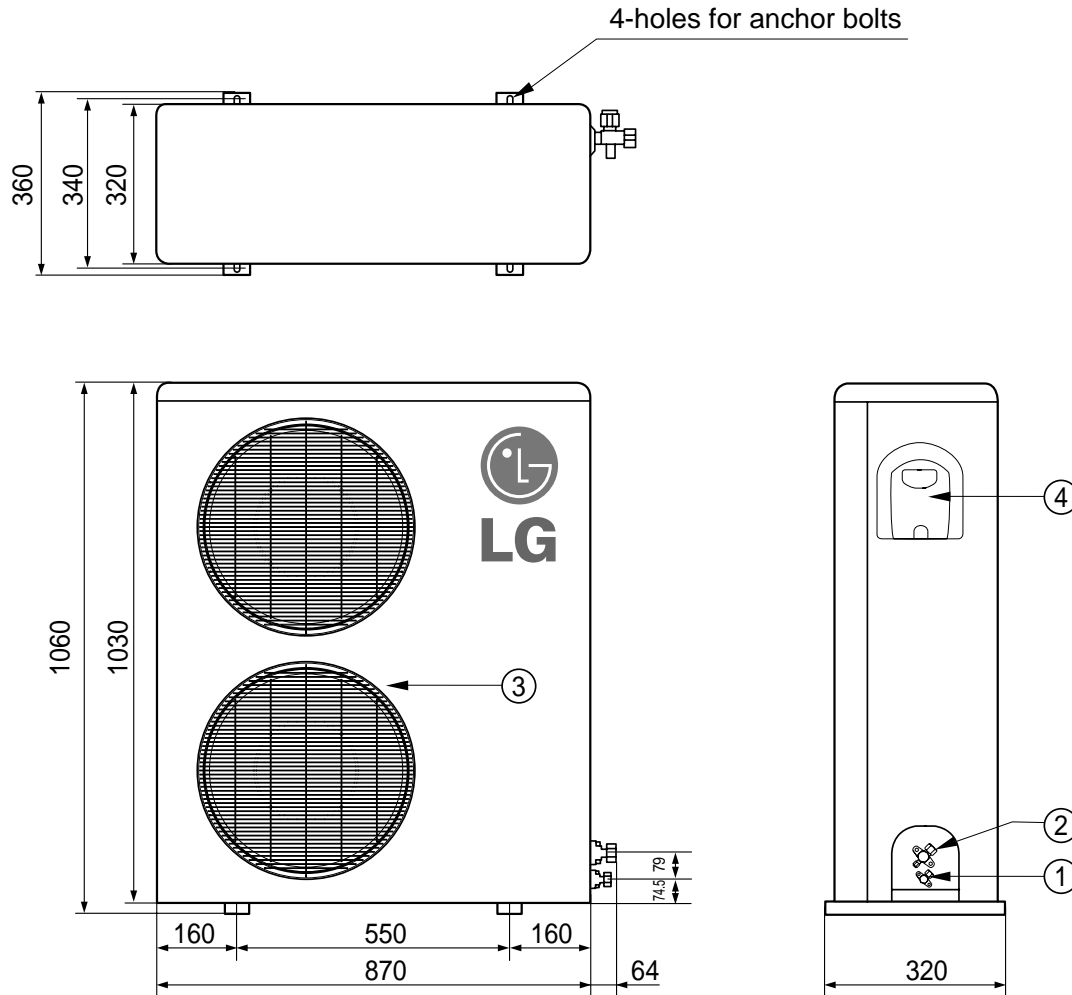

Number	Name	Description
1	Liquid side service valve(mm)	Ø6.35
2	Gas side service valve(mm)	Ø15.88
3	Air discharge grill	
4	Control Cover	

**Model No.: AUUC488A/AB, AUUH488A/AB, AUUC608A/AB, AUUH608A/AB**

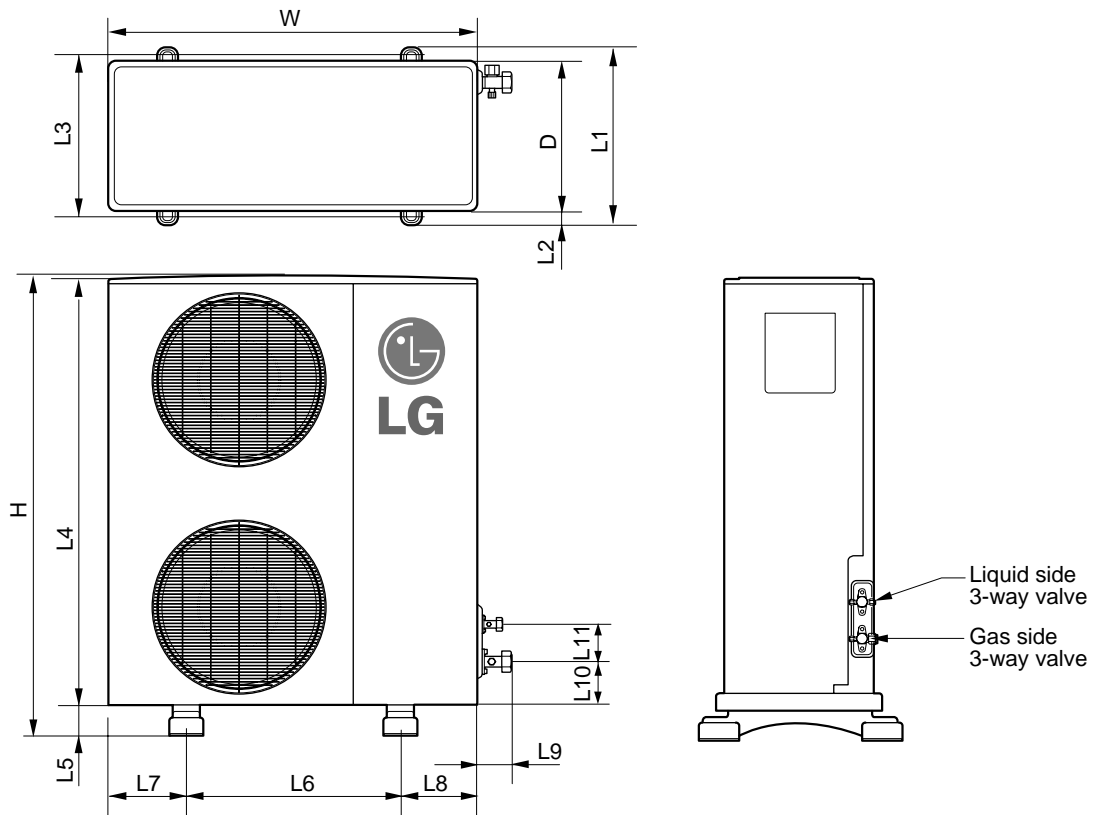

Model No.		AUUC488A/AB, AUUH488A/AB, AUUC608A/AB, AUUH608A/AB
W	mm	900
H	mm	1,225
D	mm	370
L1	mm	460
L2	mm	45
L3	mm	410
L4	mm	1,135
L5	mm	90
L6	mm	550
L7	mm	175
L8	mm	175
L9	mm	112
L10	mm	120
L11	mm	83

# Wiring Diagrams

## 1. Indoor Unit

### Ceiling Cassette Type / Cooling Only; ATNC-EL/FL Series

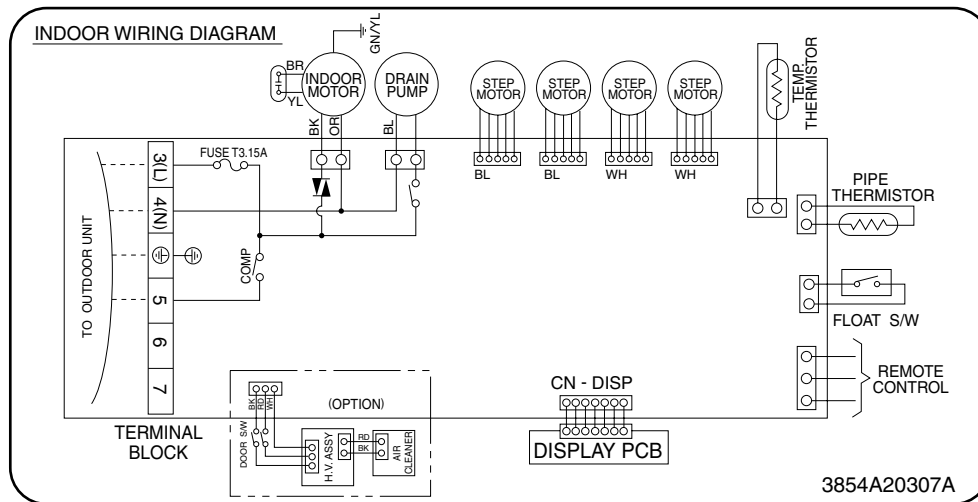

### Ceiling Cassette Type / Cooling Only; ATNC-DL Series

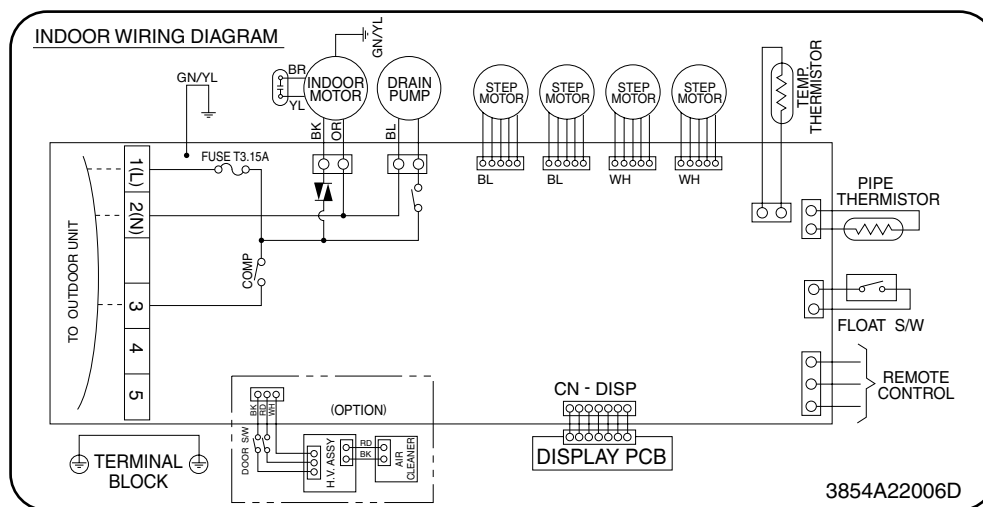

Notes:

BR	BROWN	OR	ORANGE	RD	RED
WH	WHITE	YL	YELLOW	GN/YL	GREEN/YELLOW
BL	BLUE	BK	BLACK		

**Ceiling Cassette Type / Heat Pump; ATNH-EL/FL Series**

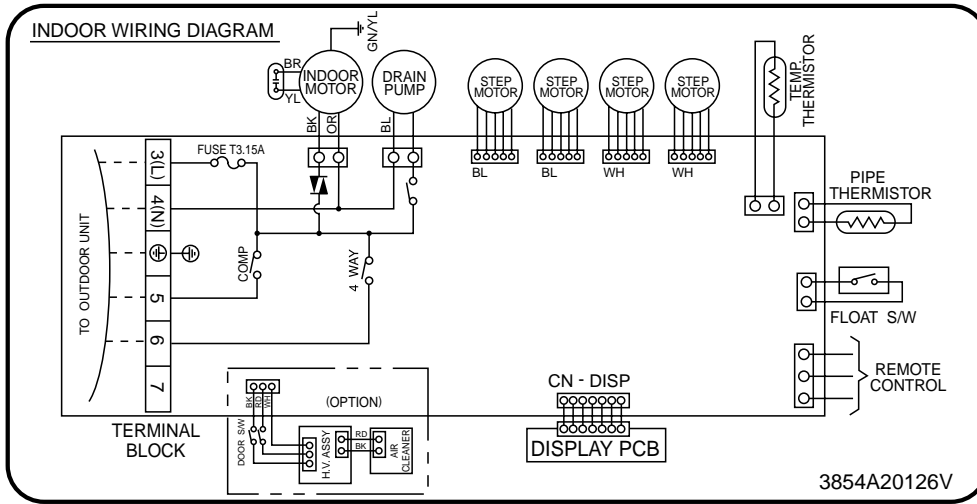

**Ceiling Cassette Type / Heat Pump; ATNH-DL Series**

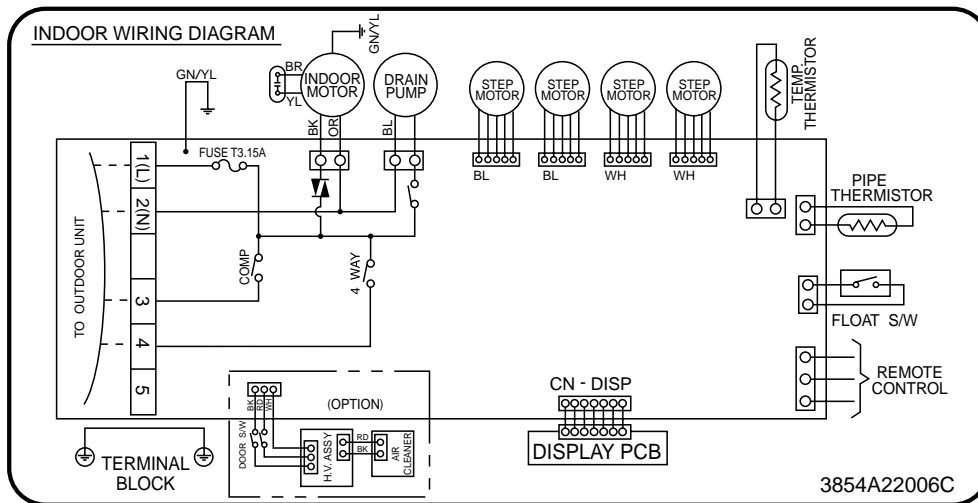

Notes:

BR	BROWN	OR	ORANGE	RD	RED
WH	WHITE	YL	YELLOW	GN/YL	GREEN/YELLOW
BL	BLUE	BK	BLACK		

**Ceiling Concealed Duct Type / Cooling Only; ABNC-HL/GL Series**

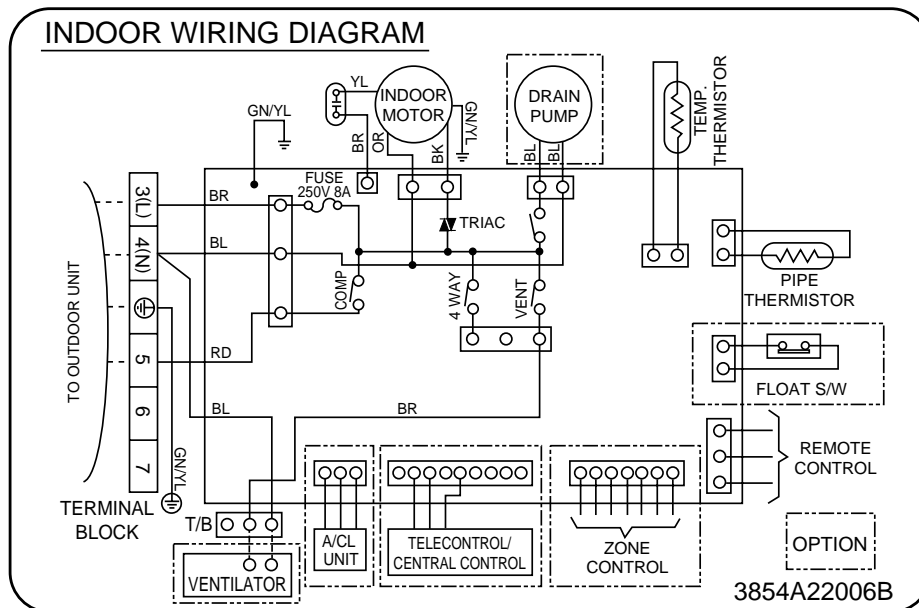

**Ceiling Concealed Duct Type / Cooling Only; ABNC-EL Series**

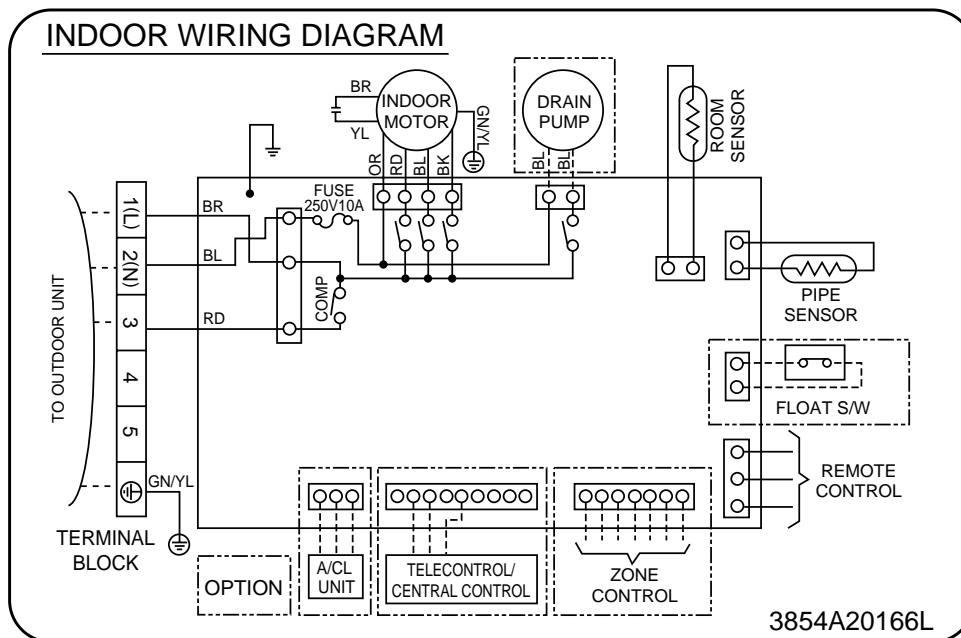

Notes:

BR	BROWN	OR	ORANGE	RD	RED
WH	WHITE	YL	YELLOW	GN/YL	GREEN/YELLOW
BL	BLUE	BK	BLACK		

**Ceiling Concealed Duct Type / Heat Pump ; ABNH-HL/GL Series**

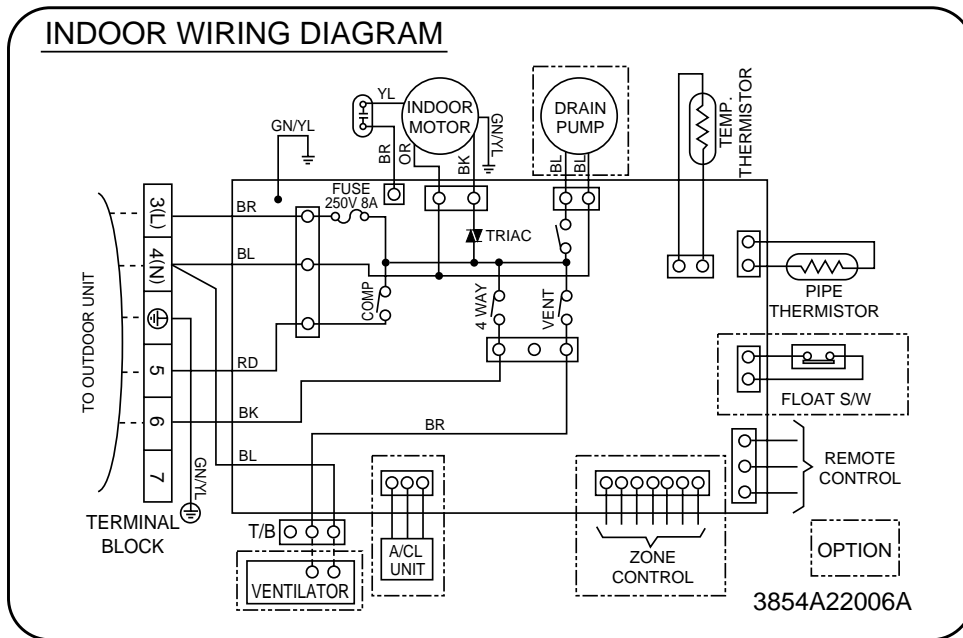

**Ceiling Concealed Duct Type / Heat Pump ; ABNH-EL Series**

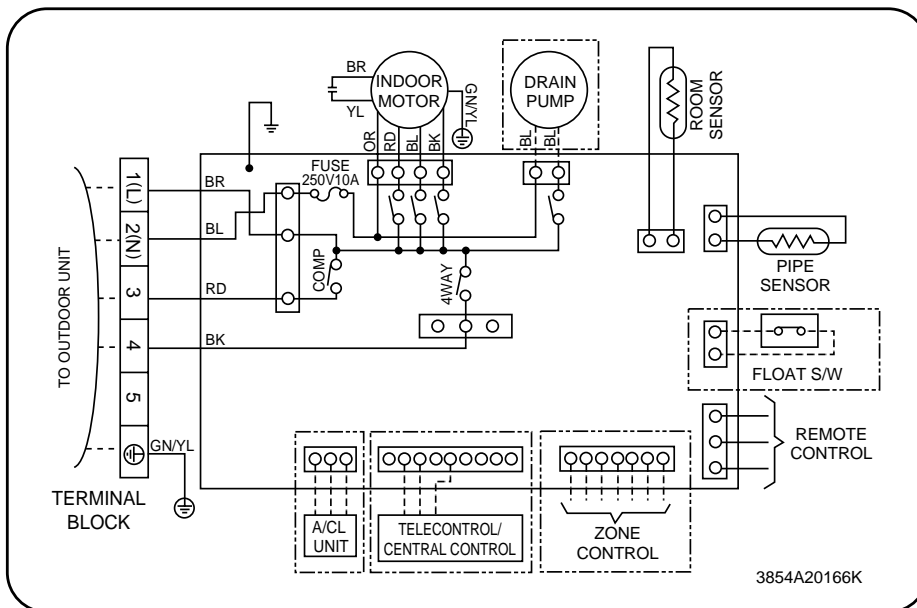

Notes:

BR	BROWN	OR	ORANGE	RD	RED
WH	WHITE	YL	YELLOW	GN/YL	GREEN/YELLOW
BL	BLUE	BK	BLACK		

**Ceiling & Floor Type / Cooling Only ; AVNC-BL Series**

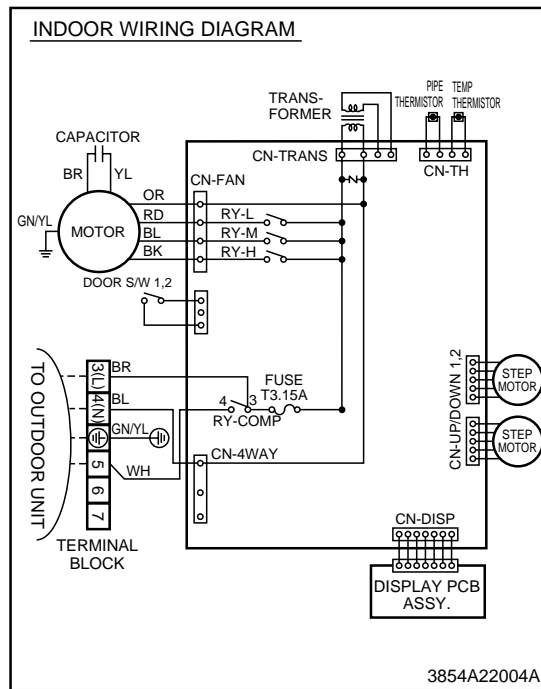

**Ceiling & Floor Type / Heat Pump ; AVNH-BL Series**

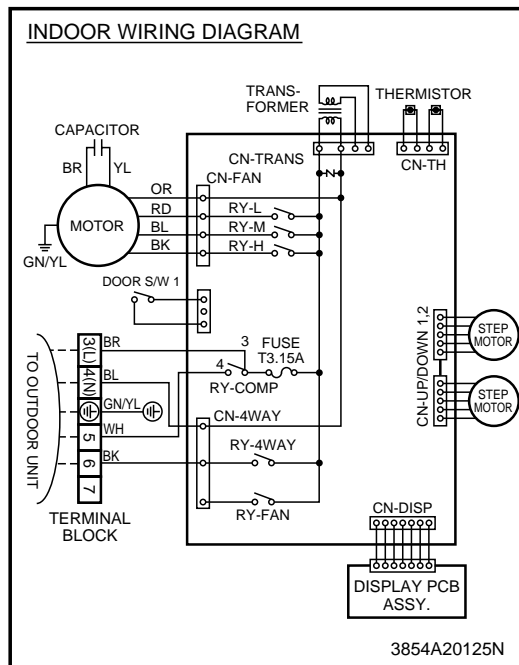

Notes:

BR	BROWN	OR	ORANGE	RD	RED
WH	WHITE	YL	YELLOW	GN/YL	GREEN/YELLOW
BL	BLUE	BK	BLACK		

## 2. Outdoor Unit

### Cooling Only : AUUC186A/AUUC246A/AUUC306A

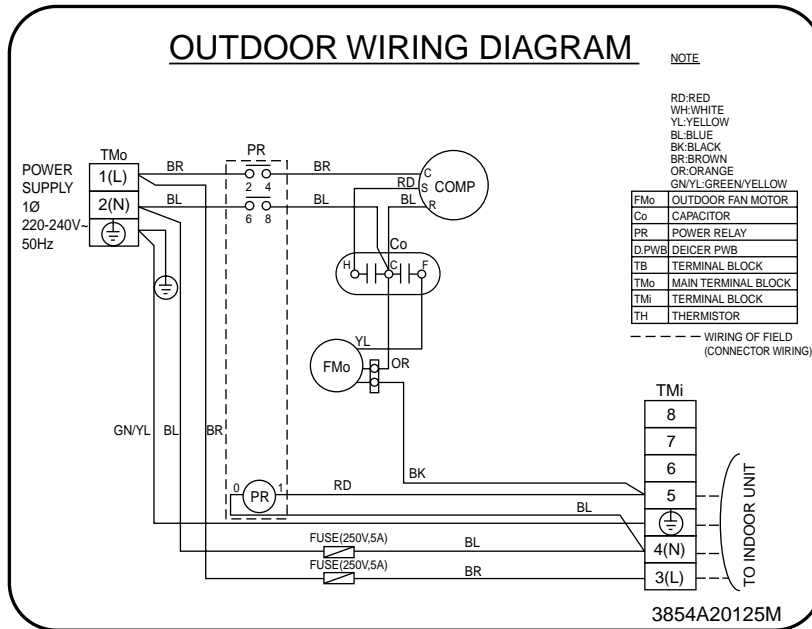

### Cooling Only : AUUC368A/AUUC488A/AUUC608A

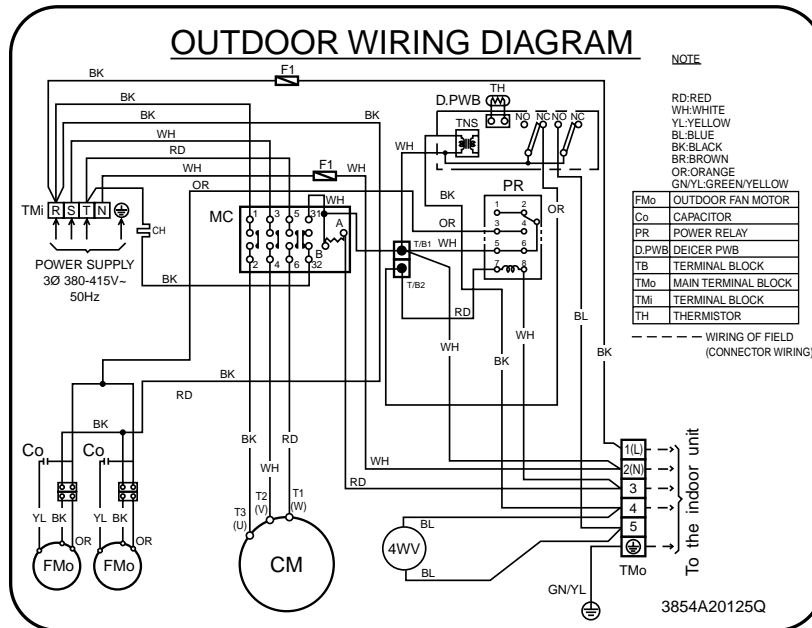



Heat Pump : AUUH186A/AUUH246A/AUUH306A

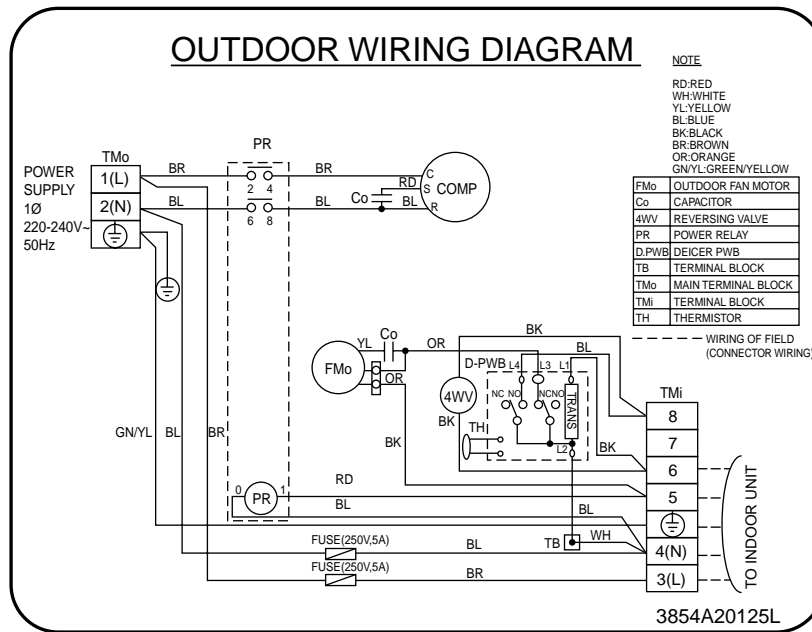

Heat Pump : AUUH368A/AUUH488A/AUUH608A

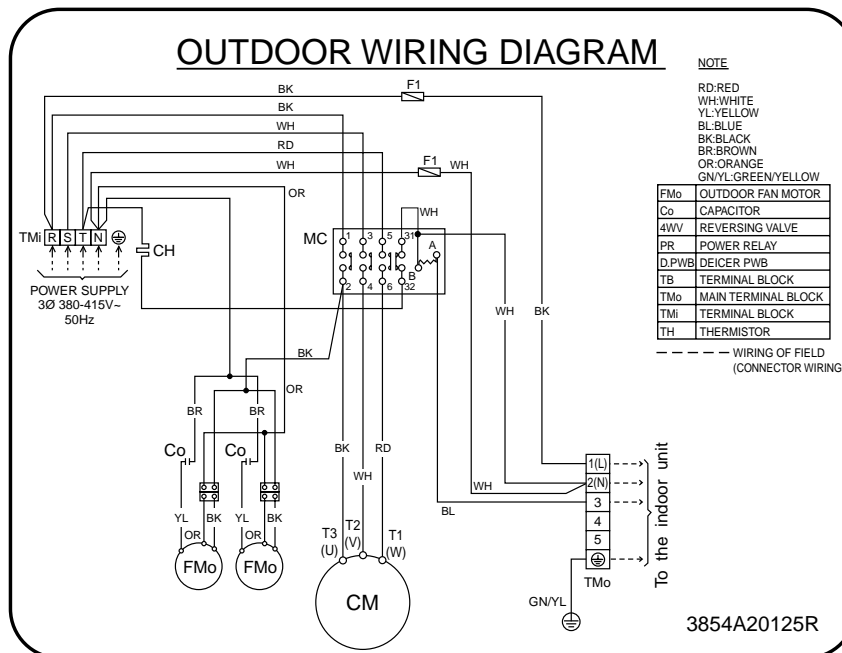

**Cooling Only : AUUC186AB/AUUC246AB/AUUC306AB**

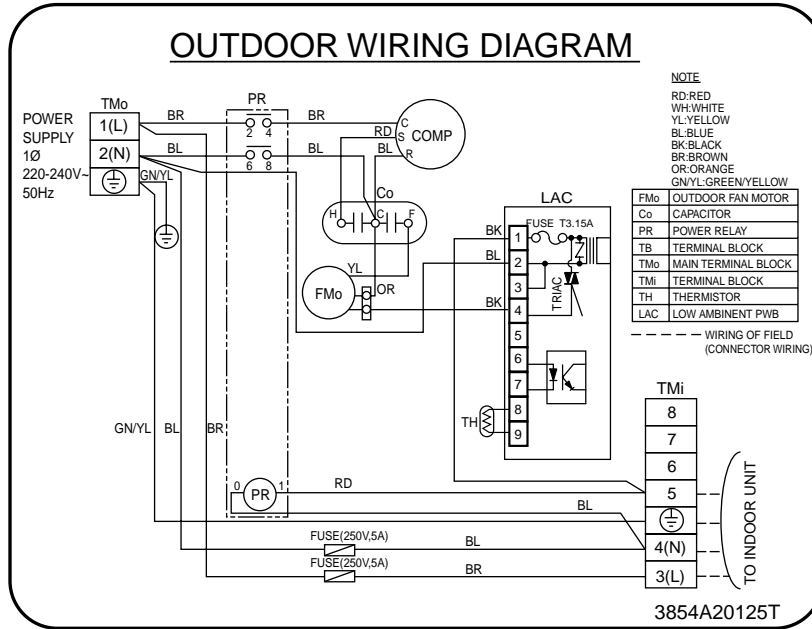

**Cooling Only : AUUC368AB/AUUC488AB/AUUC608AB**

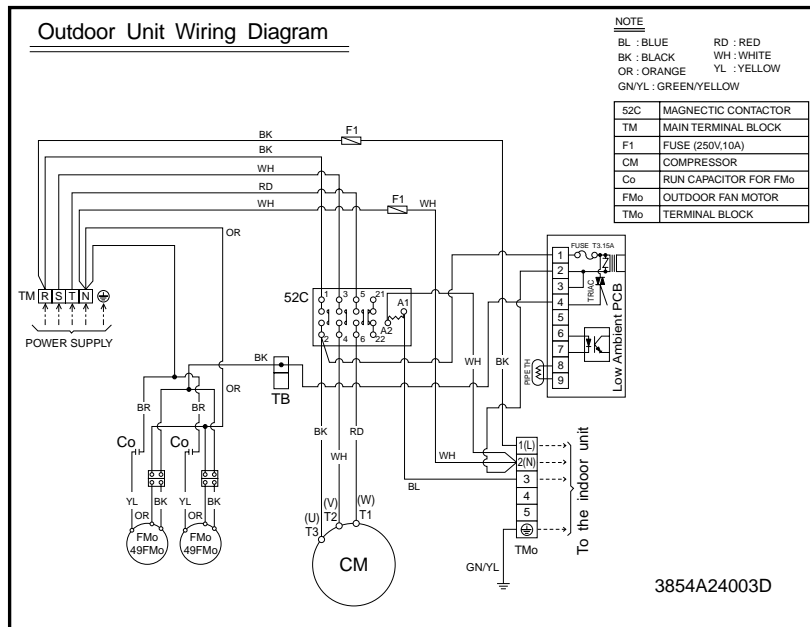

**Heat Pump : AUUH186AB/AUUH246AB/AUUH306AB**

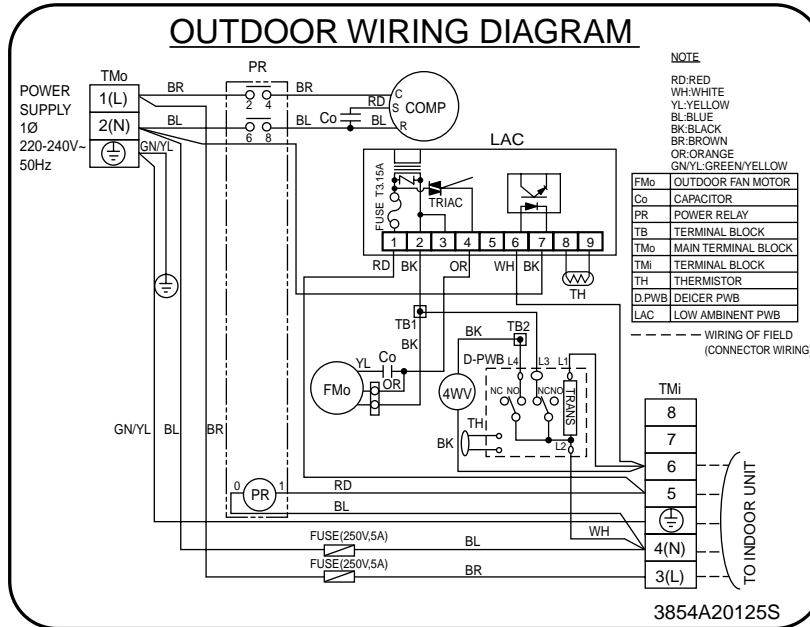

**Heat Pump : AUUH368AB/AUUH488AB/AUUH608AB**

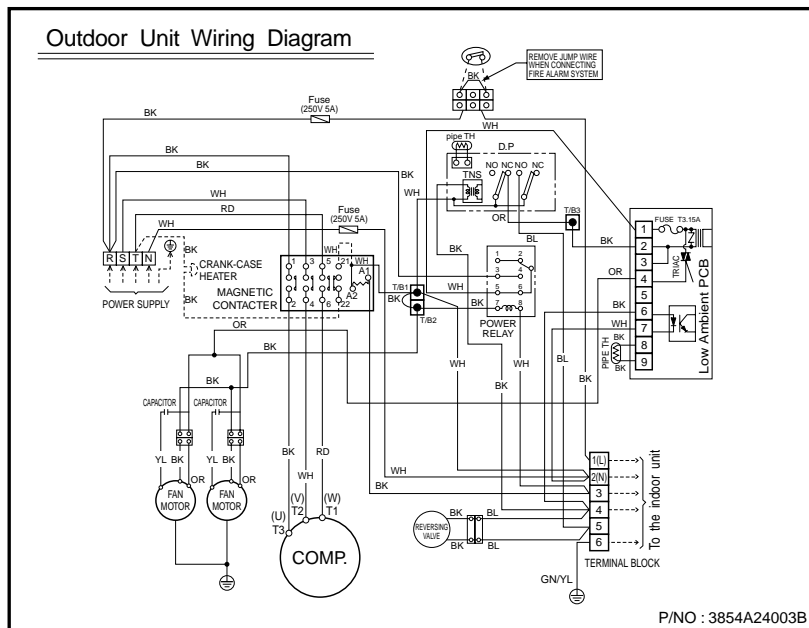

# Refrigerant Cycle Diagrams

## 1. Cooling Only Models

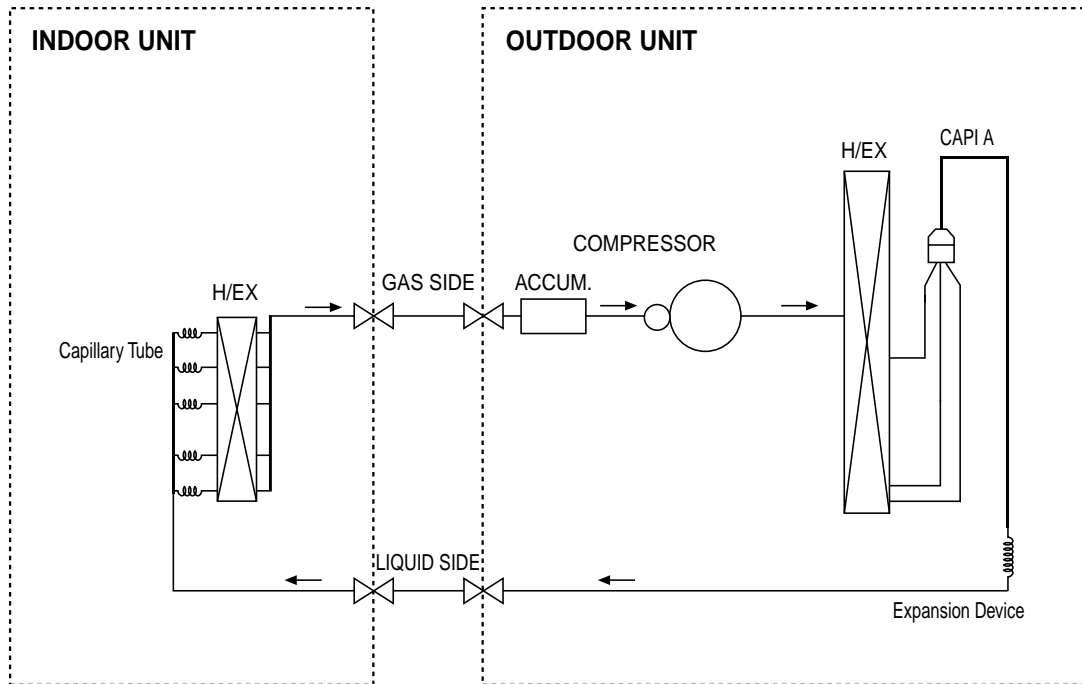

Indoor Unit	Pipe Size(Diameter:Ø) inch		Piping length (m)		Elevation (m)		Additional Refrigerant (g/m)
	Gas	Liquid	Rated	Max.	Rated	Max.	
ATNC186ELAA ATNC186ELCA ABNC186HLAA AVNC186BLAA	5/8	1/4	7.5	50	7.5	30	25
ATNC246FLAA ATNC246FLCA ABNC246HLAA AVNC246BLAA							
ATNC306FLAA ATNC306FLCA ABNC306GLAA AVNC306BLAA							
ATNC368DLAA ATNC368DLCA ABNC368GLAA							
ATNC488DLAA ATNC488DLCA ABNC488ELAA	3/4	3/8	7.5	50	7.5	30	50
ATNC608DLAA ATNC608DLCA ABNC608ELAA	3/4	1/2					

## 2. Heat Pump Models

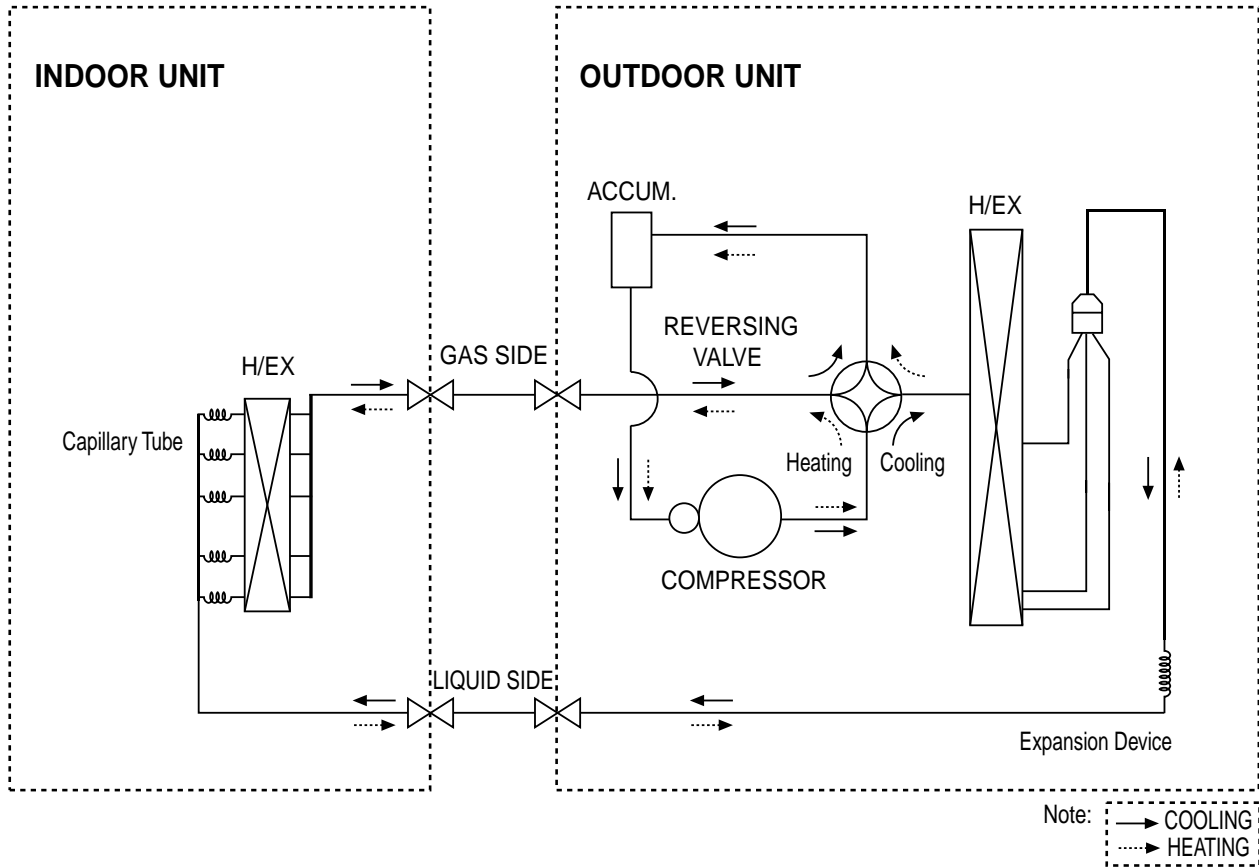

Indoor Unit	Pipe Size(Diameter:Ø) inch		Piping length (m)		Elevation (m)		Additional Refrigerant (g/m)
	Gas	Liquid	Rated	Max.	Rated	Max.	
ATNH186ELAA ATNH186ELCA ABNH186HLAA AVNH186BLAA	5/8	1/4	7.5	50	7.5	30	30
ATNH246FLAA ATNH246FLCA ABNH246HLAA AVNH246BLAA							
ATNH306FLAA ATNH306FLCA ABNH306GLAA AVNH306BLAA							
ATNH368DLAA ATNH368DLCA ABNH368GLAA							
ATNH488DLAA ATNH488DLCA ABNH488ELAA	3/4	3/8	7.5	50	7.5	30	50
ATNH608DLAA ATNH608DLCA ABNH608ELAA	3/4	1/2					80

# Electrical Data

Nominal Capacity (Btu/hr)	Indoor Unit	Outdoor Unit	V-PH-Hz	Operating Voltage		Compressor		Indoor Fan FLA	Outdoor LRA	Power			
				Minimum	Maximum	RLA	Fan FLA			MCA	MFA		
18k	ATNC186ELAA	AUUC186A/AB	220~240-1-50	198V	264V	7.1	32.3	1.0	0.7	10.6	20		
	ATNC186ELCA		220~240-1-50			7.1		1.0		10.6	20		
	ABNC186HLAA		220~240-1-50			7.8		1.2		11.6	20		
	AVNC186BLAA		220~240-1-50			8.1		0.3		11.1	20		
	ATNH186ELAA	AUUH186A/AB	220~240-1-50			6.9	32.3	1.0		10.3	20		
	ATNH186ELCA		220~240-1-50			6.9		1.0		10.3	20		
	ABNH186HLAA		220~240-1-50			7.4		1.2		11.1	20		
	AVNH186BLAA		220~240-1-50			7.7		0.3		10.6	20		
24k	ATNC246FLAA	AUUC246A/AB	220~240-1-50	198V	264V	9.7	62	0.7	0.7	13.6	20		
	ATNC246FLCA		220~240-1-50			9.7		0.7		13.6	20		
	ABNC246HLAA		220~240-1-50			10.1		1.2		14.5	20		
	AVNC246BLAA		220~240-1-50			10		0.4		13.6	20		
	ATNH246FLAA	AUUH246A/AB	220~240-1-50			9.6	62	0.7		13.4	20		
	ATNH246FLCA		220~240-1-50			9.6		0.7		13.4	20		
	ABNH246HLAA		220~240-1-50			9.9		1.2		14.2	20		
	AVNH246BLAA		220~240-1-50			10.1		0.4		13.7	20		
30k	ATNC306FLAA	AUUC306A/AB	220~240-1-50	198V	264V	11.4	68	0.9	0.7	15.8	25		
	ATNC306FLCA		220~240-1-50			11.4		0.9		15.8	25		
	ABNC306GLAA		220~240-1-50			11.9		1.7		17.3	25		
	AVNC306BLAA		220~240-1-50			12.1		0.5		16.3	25		
	ATNH306FLAA	AUUH306A/AB	220~240-1-50			11.8	68	0.9		16.3	25		
	ATNH306FLCA		220~240-1-50			11.8		0.9		16.3	25		
	ABNH306GLAA		220~240-1-50			12.2		1.7		17.6	25		
	AVNH306BLAA		220~240-1-50			12.3		0.5		16.6	25		
36k	ATNC368DLAA	AUUC368A/AB	380~415-3-50	342V	456V	4.9	47	1	0.9	8.1	20		
	ATNC368DLCA		380~415-3-50			4.9		1		8.1	20		
	ABNC368GLAA		380~415-3-50			5.2		1.8		9.2	20		
	ATNH368DLAA	AUUH368A/AB	380~415-3-50			4.9	47	1		8.1	20		
	ATNH368DLCA		380~415-3-50			4.9		1		8.1	20		
	ABNH368GLAA		380~415-3-50			5.2		1.8		9.2	20		
48k	ATNC488DLAA	AUUC488A/AB	380~415-3-50			342V	456V	6.5	63	2	1.6	11.8	20
	ATNC488DLCA		380~415-3-50					6.5		2		11.8	20
	ABNC488ELAA		380~415-3-50					6.8		3.8		13.9	20
	ATNH488DLAA	AUUH488A/AB	380~415-3-50					6.5	63	2		11.8	20
	ATNH488DLCA		380~415-3-50					6.5		2		11.8	20
	ABNH488ELAA		380~415-3-50					6.8		3.8		13.9	20
60k	ATNC608DLAA	AUUC608A/AB	380~415-3-50	342V	456V			6.9	81	2.3	1.6	12.7	25
	ATNC608DLCA		380~415-3-50					6.9		2.3		12.7	25
	ABNC608ELAA		380~415-3-50					7.9		3.8		15.3	25
	ATNH608DLAA	AUUH608A/AB	380~415-3-50					6.9	81	2.3		12.7	25
	ATNH608DLCA		380~415-3-50					6.9		2.3		12.7	25
	ABNH608ELAA		380~415-3-50					7.9		3.8		15.3	25
			380~415-3-50			7.9	3.8	15.3		25			

**NOTES :**

- Voltage Range  
Units are suitable for use on electrical system where voltage supplied to unit terminals is not below or above listed range limits.
- Maximum allowable voltage unbalance between phase is 2%.
- MCA/MFA  
MCA = 1.25 x Max. RLA + other RLA + each FLA  
MFA = 2.25 x Max. RLA + other RLA + each FLA  
( Next lower standard fuse rating. Minimum 20A)
- Select wire size based on the MCA
- MFA is used to select the circuit breaker and ground fault circuit interrupter(each leakage circuit breaker).
- RLA is based on the following conditions.  
Indoor temperature : 27°CDB / 19.0°CWB(80.6°FDB / 66.2°FWB)  
Outdoor temperature : 35°CDB(95°FDB)

# Operation Range

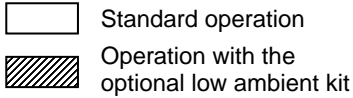
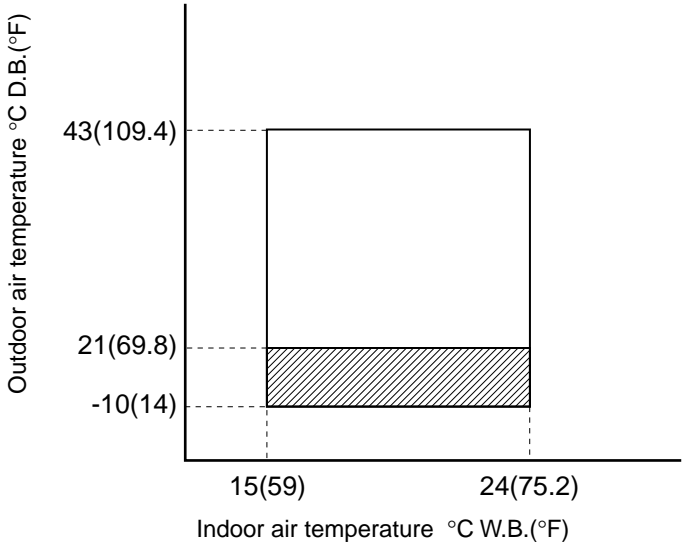
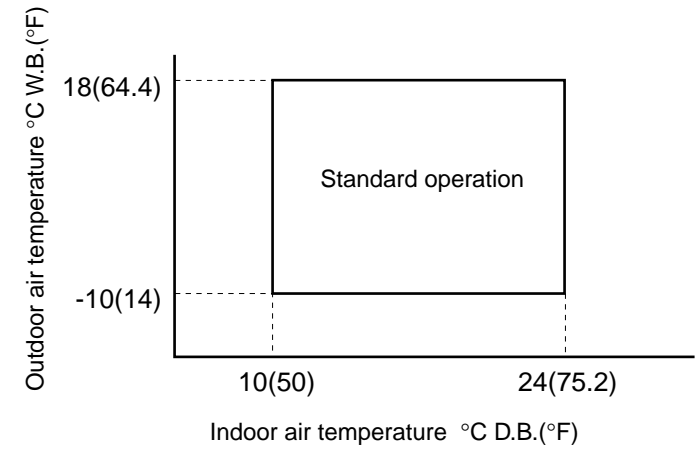
Item	Range
<p><b>Inlet air temperature (Cooling)</b></p> <div style="margin-top: 20px;">  </div> <p style="font-size: small; margin-top: 20px;">* Note: If the ambient temperature goes below 5°C(41°F), the capacity drops down even if the low ambient kit is installed.</p>	
<p><b>Inlet air temperature (Heating)</b></p>	
<p><b>Power Source Voltage</b></p>	<p><b>Rating ± 10%</b></p>
<p><b>Voltage at Starting</b></p>	<p><b>Min. 85% of rating</b></p>

# External Static Pressure & Air Flow

## 1. Ceiling Concealed Duct (ABNC-EL, ABNH-EL Models)

**Table-1**

Static Pressure(mmAq)		0	2	4	6	8	10	15
Model Name	Step	CMM(CFM)	CMM(CFM)	CMM(CFM)	CMM(CFM)	CMM(CFM)	CMM(CFM)	CCMM(CFM)
ABNC488ELAA ABNH488ELAA	High	48.5(1,722)	46.5(1,642)	45(1,598)	43.5(1,544)	42(1,491)	40(1,420)	*40(1,420)
	Med	43(1,527)	41.5(1,466)	39.5(1,402)	38(1,349)	36.5(1,296)	35(1,243)	*35(1,243)
	Low	39(1,385)	37.5(1,324)	36(1,278)	34.5(1,225)	33(1,172)	31(1,101)	*31(1,101)
ABNC608ELAA ABNH608ELAA	High	56(1,988)	54(1,907)	52(1,836)	50(1,775)	48.5(1,722)	46(1,624)	*46(1,633)
	Med	49.5(1,757)	48(1,695)	46(1,633)	44(1,560)	42(1,491)	40(1,413)	*40.5(1,438)
	Low	43.5(1,544)	42(1,483)	40.5(1,438)	38.5(1,367)	37(1,314)	35(1,236)	*33.5(1,189)

External static pressure given after subtracting coil losses motor step factory installed.

External static pressure can be higher than the maximum given in the table, but the unit faces the problem of freezing the coil.

The assured range of air-conditioner is in the only shady part and in the other part, the specification of air-conditioner may differ with the above table.

If the static pressure of air-conditioner is out of the shady part, please adjust the static pressure.

\* Change the connection of the indoor fan motor connector to increase the motor speed to obtain similar CFM at 15 mmAq Static Pressure as at 10 mmAq Static pressure.



## 2. Ceiling Concealed Duct (ABNC-HL/GL, ABNH-HL/GL Models)

### E.S.P.(External Static Pressure) setting for phase control motor

(1) Open the rear cover of the wired remote-controller to set the mode.

(2) Select one of three selectable modes as follows.

#### ■ Without Zone System

1. Position V-H, F-H:
  - This position sets the maximum E.S.P as a default set.
2. Position V-L:
  - This position sets the minimum E.S.P as a default set.

#### ■ With Zone System

1. Position V-H:
  - Maximum E.S.P setting & Fan speed is varied according to the state of dampers by micom.
2. Position F-H:
  - Maximum E.S.P setting & Fan speed doesn't vary according to the opening & Closing of dampers.
3. Position V-L:
  - Minimum E.S.P setting & Fan speed is varied according to the state of dampers by micom.

\*Maximum: 18/24K-8mmAq  
 30/36K-10mmAq  
 Minimum: All-0mmAq

(3) Move the slide switch to set position.

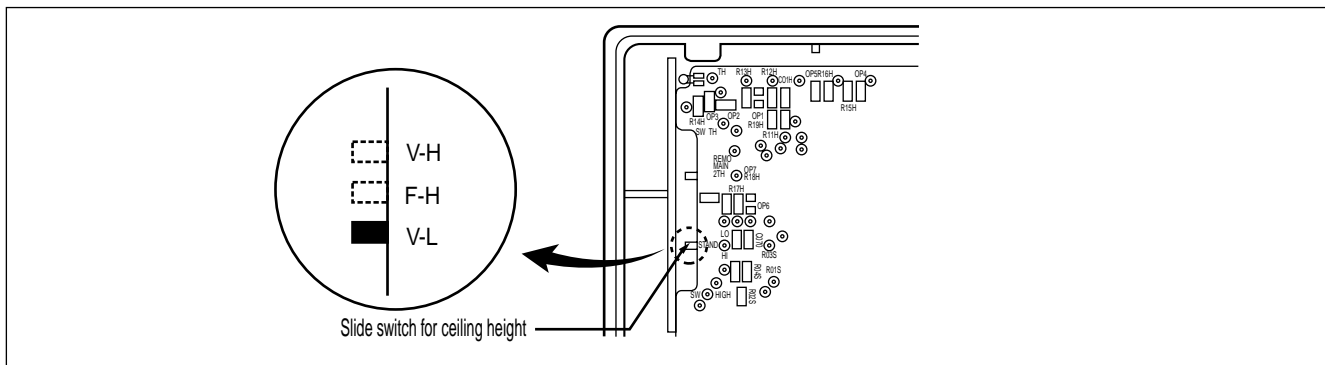

(4) Close the rear cover and check if it works normally.

#### ⚠ CAUTION

- Select the position after checking duct work and E.S.P of the unit.
- Manufactured in the position F-H.

## How to Set E.S.P?

### Procedure of RPM change:

Ex) External Static pressure is 6mmAq for Model Name "ABNH368GLAA"

- To protect the unit, compressor is designed to be off during E.S.P. setting.

- 1** Push the "On/Off" button.  
The unit will start.

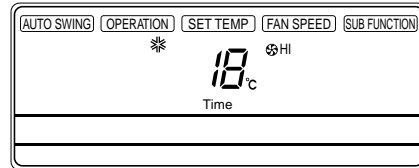
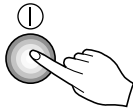

- 2** Push the "Timer" and "Wind" button simultaneously for more than 3 seconds.

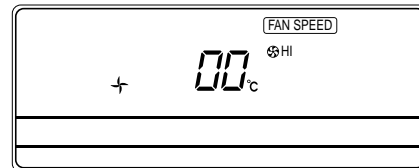
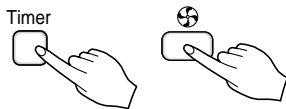

- 3** Push the "Up" or "Down" button for E.S.P adjustment.  
And, adjust the number which you want. (In this example, the number is "220". Refer to the table 15-2 on the next page.)

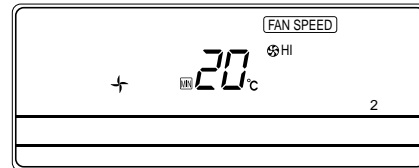
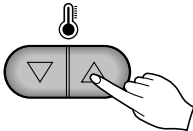

**Note:** The range of selection is from 1~254. Since, the display is two Digit only.  
If the range selection is above 100 then the third digit will appear in the screen as shown.

- 4** Shift the fan speed mode by pressing the fan speed button.  
And then, Adjust numbers of next steps by repeating the stage 3.  
(In this example, the numbers are "245" and "253" respectively.)



- 5** Push the "Timer" and "Wind" button simultaneously for more than 3 seconds.  
Then, Wind Data is memorized by the EEPROM of the main PCB.

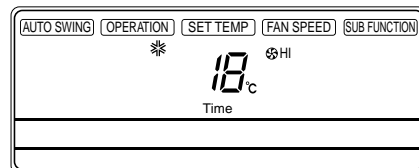

**Table-2**

Static Pressure(mmAq.)			0	2	4	6	8	10
Model Name	Step	CMM(CFM)	Setting Value					
ABNC186HLAA ABNH186HLAA	Hi	16.5(583)	235	230	225	215	180	
	Med	14.5(512)	245	238	235	230	215	
	Lo	13.0(459)	254	252	248	245	240	
ABNC246HLAA ABNH246HLAA	Hi	18.0(636)	220	205	190	50	1	
	Med	16.5(583)	235	230	220	200	100	
	Lo	14.0(494)	250	240	235	230	210	
ABNC306GLAA ABNH306GLAA	Hi	26(918)	170	168	165	160	148	60
	Med	23(812)	185	183	181	180	177	165
	Lo	20(706)	198	198	198	198	198	195
ABNC368GLAA ABNH368GLAA	Hi	32.0(1130)	230	230	230	220	150	1
	Med	29.0(1024)	240	240	240	235	230	220
	Lo	26.5(936)	245	245	245	245	240	240

**Note: 1. To get the desired Airflow & E.S.P combination from the table set the matching value from the table. Value other than that in table will not give the combinations of airflow & ESP which are mentioned in the table.**

**2. Table 15-2 is based at 230V. According to the fluctuation of voltage, air flow rate varies.**

**Table-3**

Static Pressure(mmAq.)		Setting Value	0	2	4	6	8	10
Model Name	Step		CMM(CFM)	CMM(CFM)	CMM(CFM)	CMM(CFM)	CMM(CFM)	CMM(CFM)
ABNC186HLAA ABNH186HLAA	Hi	180	22(777)	21(742)	19.8(699)	18.3(646)	16.5(583)	
	Med	215	18.5(653)	17.8(629)	17.1(604)	16.2(572)	14.5(512)	
	Lo	240	16.1(569)	15.6(551)	15.1(533)	14.2(501)	13(459)	
ABNC246HLAA ABNH246HLAA	Hi	1	24(848)	22.5(795)	20.8(735)	19(671)	18(636)	
	Med	100	21.3(752)	19.9(703)	18.7(660)	17.2(607)	16.5(583)	
	Lo	210	17(600)	16.1(569)	15.6(551)	14.7(519)	14(494)	
ABNC306GLAA ABNH306GLAA	Hi	60	34.2(1208)	33.1(1169)	31.7(1119)	29.9(1056)	27.7(978)	26(918)
	Med	165	27(954)	26.3(929)	26.1(922)	25.8(911)	24.8(876)	23(812)
	Lo	195	21(742)	20.8(735)	20.6(727)	20.4(720)	20.4(720)	20(706)
ABNC368GLAA ABNH368GLAA	Hi	1	42(1483)	40(1413)	38(1342)	35.5(1254)	33.5(1183)	32(1130)
	Med	220	39(1377)	37(1307)	35(1236)	33(1165)	31(1095)	29(1024)
	Lo	240	34(1201)	32.5(1148)	31(1095)	29.5(1042)	27(954)	26.5(936)

**Note: 1) The above table shows the correlation of External Static Pressure & Air Flow.**

**2) Duct work must go designed within the range of [ ] on installing the unit.**

**3) If duct work is designed under [ ] External Static Pressure adjust the External Static Pressure applying air damper.**

# Installation

## 1. Select the best location

### 1.1 Indoor Unit

Install the air conditioner in the location that satisfies the following conditions.

#### Ceiling Cassette Type

- There should not be any heat source or steam near the unit.
- There should not be any obstacle to the air circulation.
- A place where air circulation in the room will be good.
- A place where drainage can be easily obtained.
- A place where noise prevention is taken into consideration.
- Do not install the unit near the door way.
- Ensure the spaces indicated by arrows from the wall, ceiling, or other obstacles.
- The indoor unit must have sufficient maintenance space.

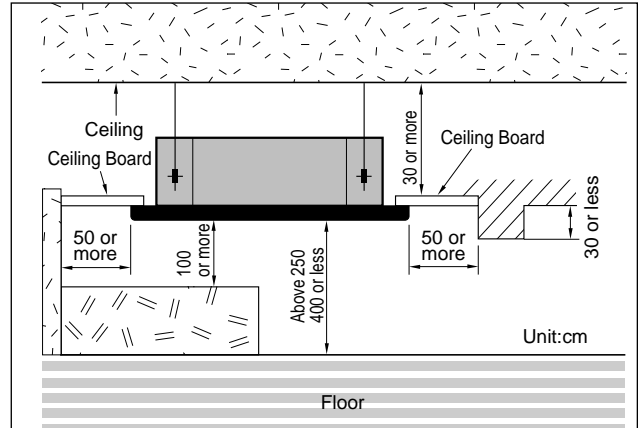

#### Ceiling & Floor Type

- There should not be any heat source or steam near the unit.
- There should not be any obstacle to prevent the air circulation.
- A place where air circulation in the room will be good.
- A place where drainage can be easily obtained.
- A place where noise prevention is taken into consideration.
- Do not install the unit near the door way.
- Ensure sufficient spaces as indicated by arrows from the wall, ceiling, or other obstacles.

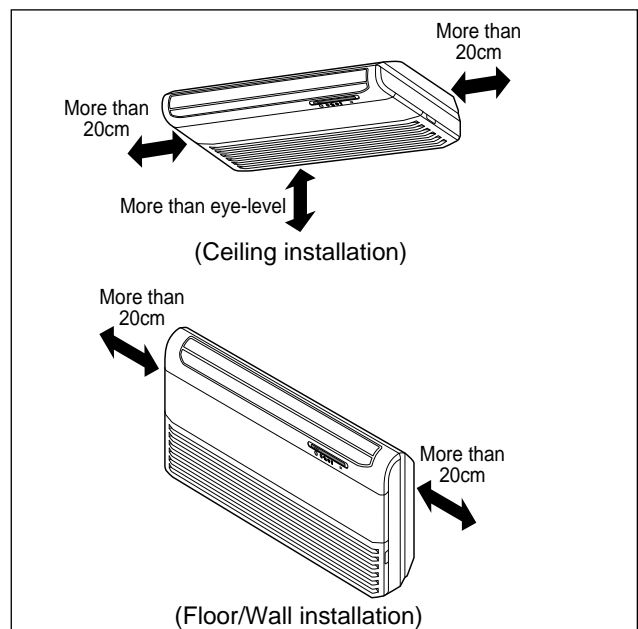

#### Ceiling Concealed Duct Type

- The place shall easily bear a load exceeding four times the indoor unit's weight.
- The place shall be able to inspect the unit as the figure.
- The place where the unit shall be leveled.
- The place shall allow easy water drainage. (Suitable dimension "H" is necessary to get a slope to drain as figure.)
- The place shall easily connect with the outdoor unit.
- The place where the unit is not affected by an electrical noise.
- The place where air circulation in the room will be good.
- There should not be any heat source or steam near the unit.

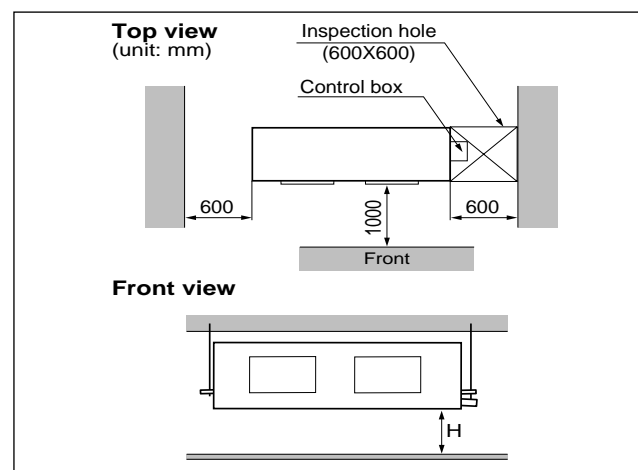

## 1.2 Outdoor Unit

- If an awning is built over the unit to prevent direct sunlight or rain exposure, make sure that heat radiation from the condenser is not restricted.
- Ensure that the space around the back is more than 30cm and sides is more than 30cm. The front of the unit should have more than 70cm of space.
- Do not place animals and plants in the path of the warm air.
- Take the air conditioner weight into account and select a place where noise and vibration are minimum.
- Select a place so that the warm air and noise from the air conditioner do not disturb neighbors.
- Rooftop Installations : If the outdoor unit is installed on a roof structure, be sure to level the unit. Ensure the roof structure and anchoring method are adequate for the unit location. Consult local codes regarding rooftop mounting.

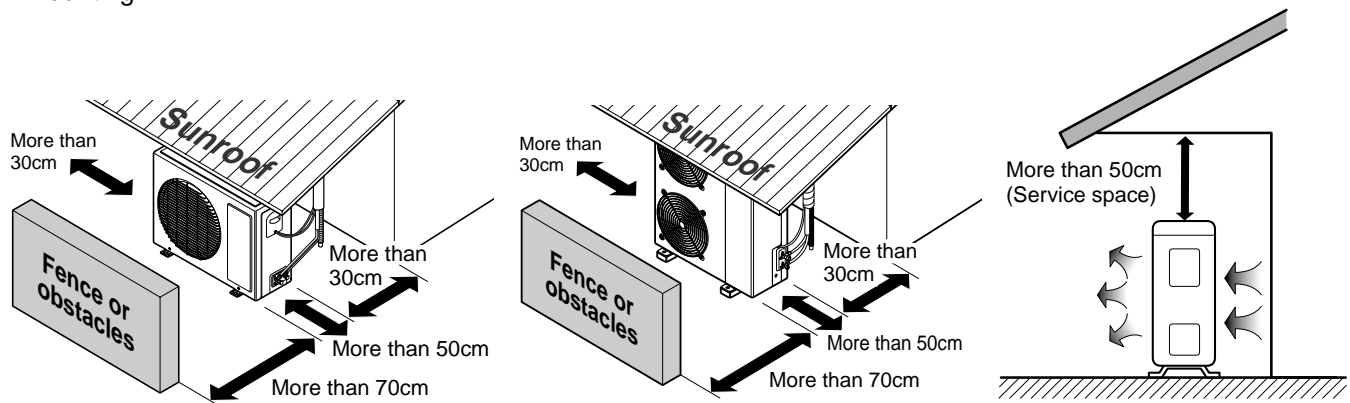

## 2. Settlement of outdoor unit

- Anchor the outdoor unit with a bolt and nut( $\varnothing 10\text{mm}$ ) tightly and horizontally on a concrete or rigid mount.
- When installing on the wall, roof or rooftop, anchor the mounting base securely with a nail or wire assuming the influence of wind and earthquake.
- In the case when the vibration of the unit is conveyed to the hose, secure the unit with an anti-vibration rubber.

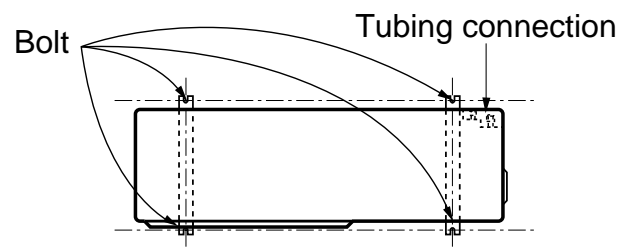

### 3. Indoor Unit Installation

#### Ceiling Cassette Type

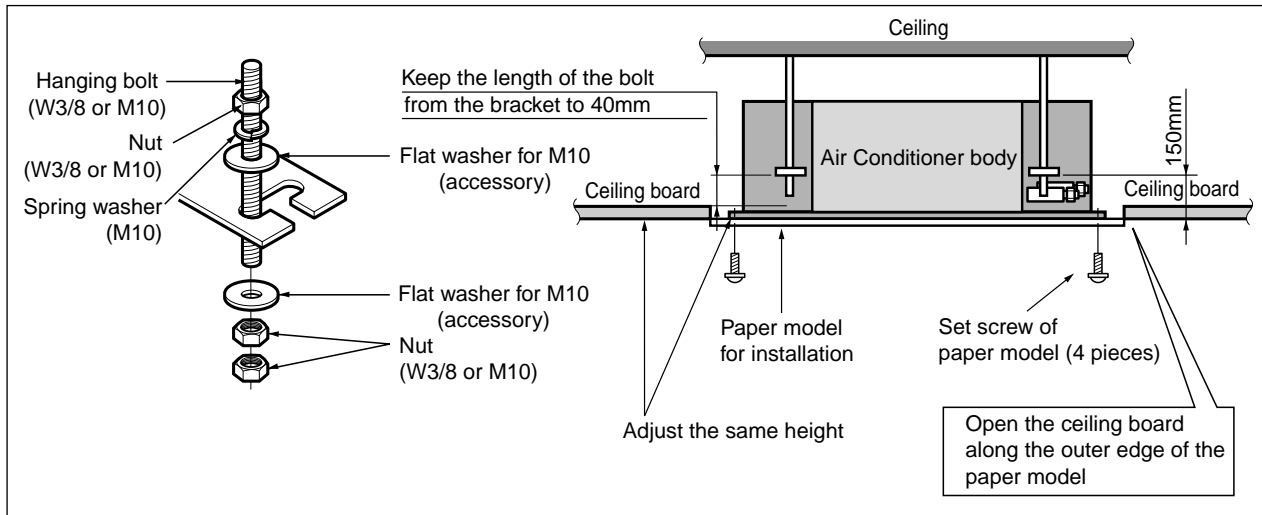

• The following parts is option.

- ① Hanging Bolt - W 3/8 or M10
- ② Nut - W 3/8 or M10
- ③ Spring Washer - M10
- ④ Plate Washer - M10

• Drill the piping hole on the wall slightly tilted to the outdoor side using a  $\varnothing 70$  hole-core drill.

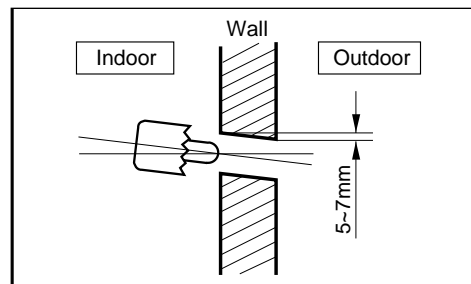

#### CAUTION

- Tighten the nut and bolt to prevent unit falling.

#### Ceiling Concealed Duct Type

##### Installation of Unit

Install the unit above the ceiling correctly.

#### CASE 1

##### POSITION OF SUSPENSION BOLT

- Apply a joint-canvas between the unit and duct to absorb unnecessary vibration.
- Apply a filter Accessory at air return hole.

► Refer to the Dimensional Drawings

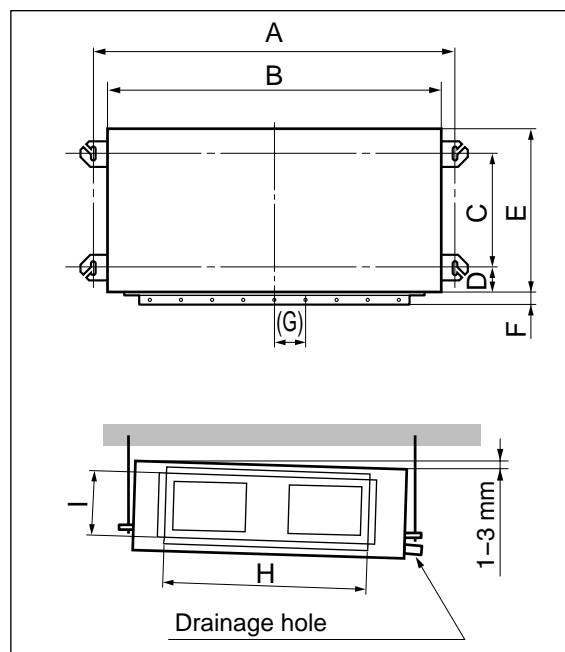

**CASE 2**

- Install the unit leaning to drainage hole side as a figure for easy water drainage.

**POSITION OF CONSOLE BOLT**

- A place where the unit will be leveled and can support the weight of the unit.
- A place where the unit can withstand its vibration.
- A place where service can be easily performed.

- Select and mark the position for fixing bolts.
- Drill the hole to set anchor on the face of ceiling.

- Insert the set anchor and washer onto the suspension bolts for locking the suspension bolts on the ceiling.
- Mount the suspension bolts to the set anchor firmly.
- Secure the installation plates onto the suspension bolts (adjust level roughly) using nuts, washers and spring washers.



**CAUTION**

Tighten the nut and bolt to prevent unit falling

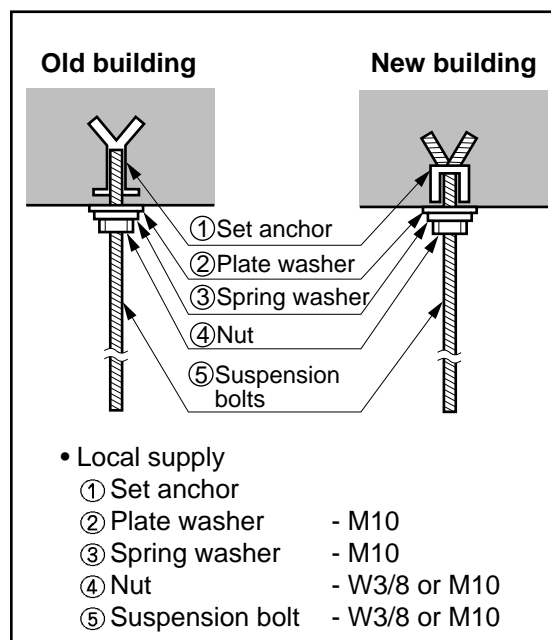
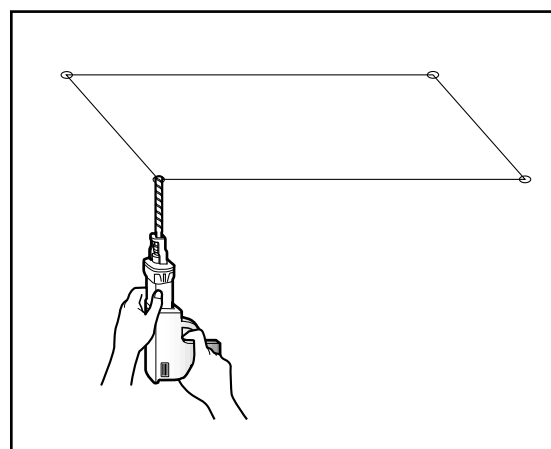
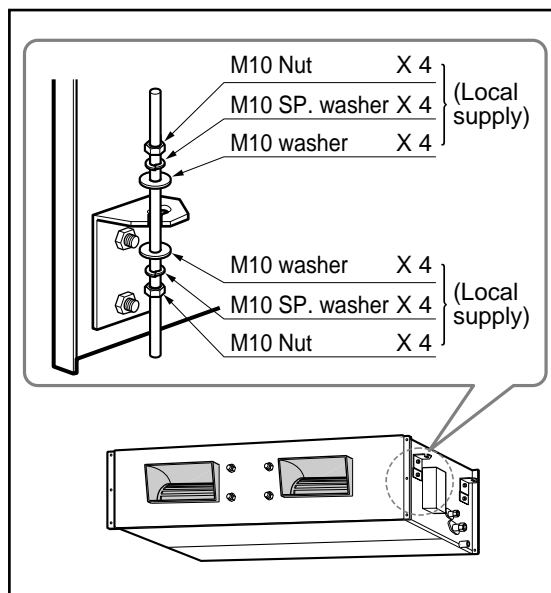

## Ceiling & Floor Type

### ■ Before Installing, prepare Installation Plates

- 'Installation Plates' are attached at the bottom of indoor unit.  
Detach them by removing each 3 screws on both sides.
- Detach 'Side Plate (R,L)' by removing each 2 screws on both sides.
- Pull the upper right and left side of 'Inlet Grille' to the front, and it will stop at slightly tilted position.
- Unhook the 'Inlet hanger' from the 'Hanger screw' on both left and right side.
- Detach the 'Inlet Grille' from the Indoor Unit.

#### 1) Installation on the ceiling

- Measure and mark the position for the Suspension bolts and the piping hole.
- Drill the hole for anchor nut on the ceiling.

※ Before securing the Installation Plates, select the bent direction of the Installation Plate to the inside or the outside according to the installation circumstances.

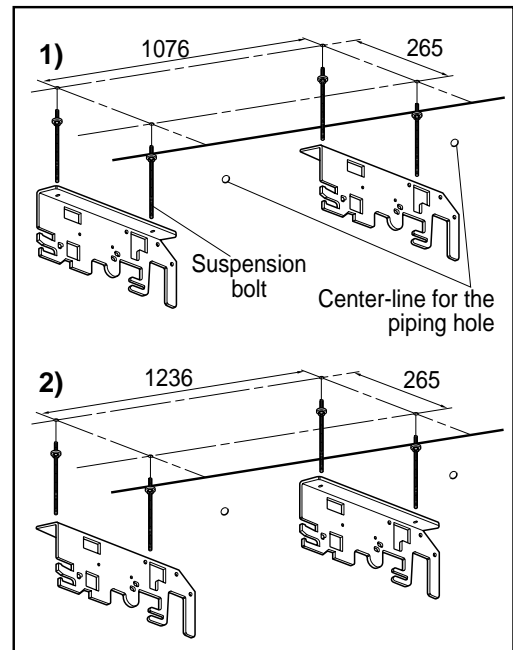
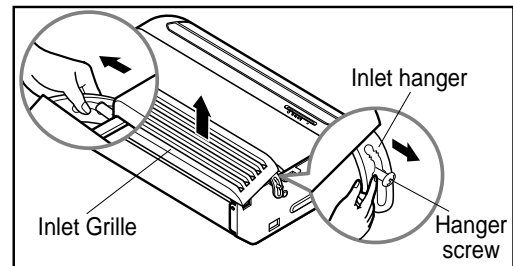
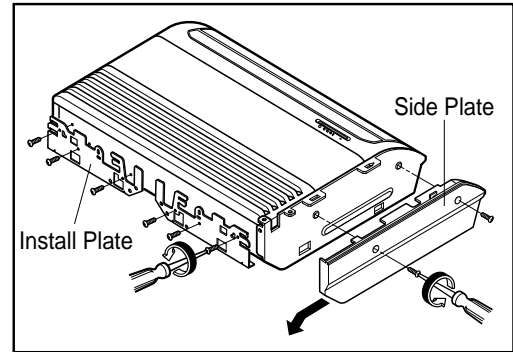



- Insert the nuts and washer into the suspension bolts for locking the suspension bolts on the ceiling.
- Mount the suspension bolts to the anchor-nuts firmly.
- Secure the Installation plates on Suspension bolts (adjust level roughly.) using nuts, washers and spring washers.

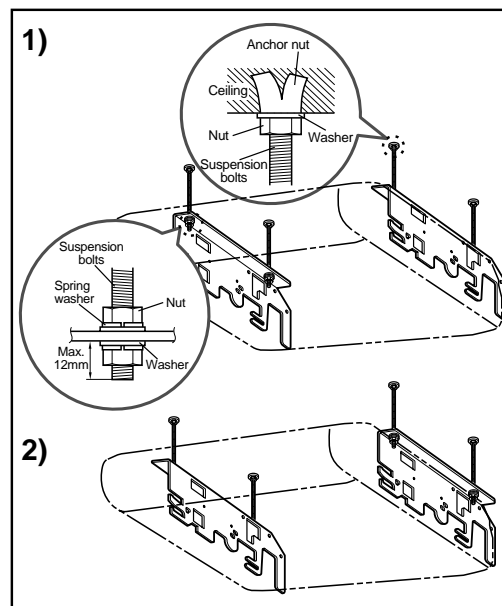

- Engage 2 hooks on both left and right side of the unit to the lower slot of Installation Plates.
- Adjust a level with a level gauge on the direction of left-right, back-forth by adjusting suspension bolts.
- Move the hooks on the unit to the upper slot of Installation Plates. Then the unit will be declined to the bottomside so as to drain well.

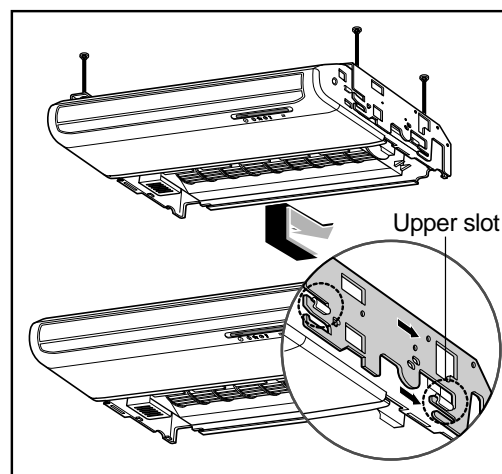
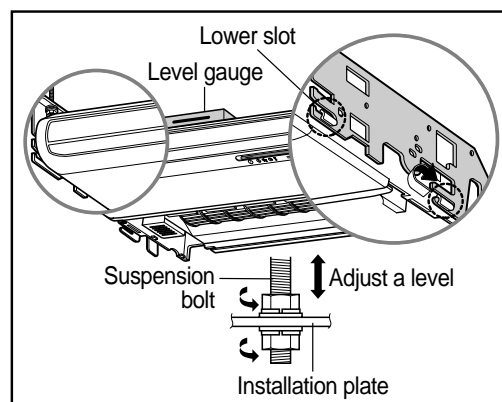

## 2) Installation on the Wall

- Select and mark the position for fixing bolts and piping hole.  
Decide the position for fixing bolts slightly tilted to the drain direction after considering the direction of drain hose.
- Drill the hole for anchor nut on the wall.

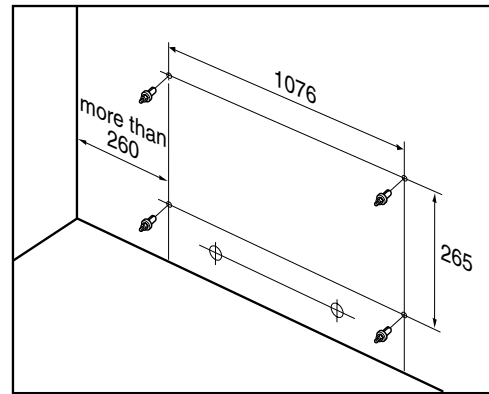

## 3) Installation on the floor

Installation of Mount Bracket.

- Select and mark the position for Mount Brackets and the piping hole.
- Drill the hole for the anchor nut on the wall.
- Drill the piping hole using a  $\varnothing 70$  hole-core drill.
- Secure the Mount Brackets on the wall with four M4 screws.

Install the indoor unit onto the Mount Brackets.

- Engage the slot at the back of the unit with Mount Bracket.

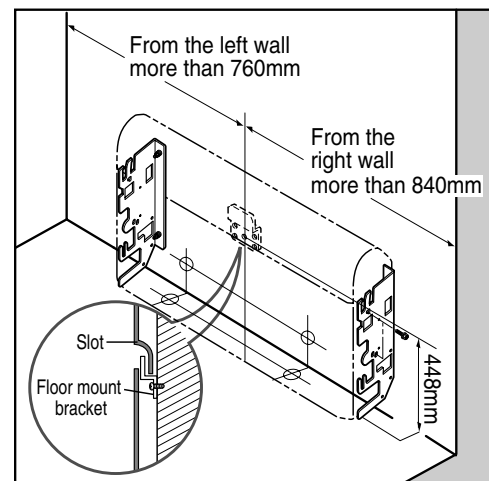

## 4. Wiring Connection

1. All wiring must comply with LOCAL REGULATIONS.
2. Select a power source that is capable of supplying the current as required by the air conditioner.
3. Feed the power source to the unit via a distribution switch board designed for this purpose.
4. The terminal screws inside the control box may be loose due to vibration during transport.  
Check the screws for loose connection.  
(Running the air conditioner with loose connection can overload and damage electrical components.)
5. Always ground the air conditioner with a grounding wire and connector to meet the LOCAL REGULATION.

### ■ 3Phase Heat Pump Model.

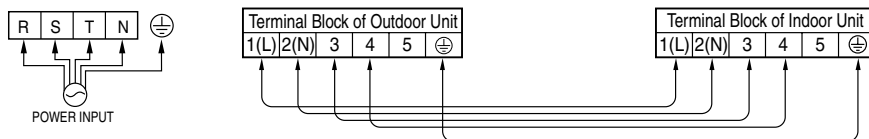

### ■ 3Phase Cooling Model Only.

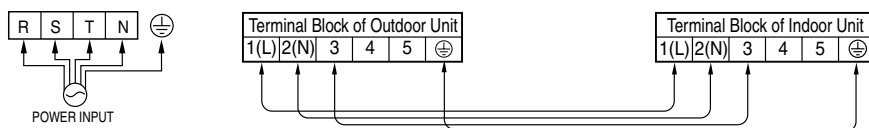

### ■ 1Phase Cooling Model Only.

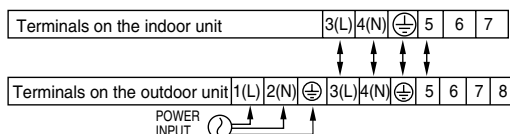

### ■ 1Phase Heat Pump Model.

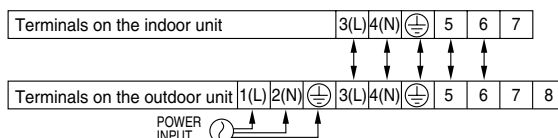

### ⚠ CAUTION

The power cord connected to the outdoor unit should be complied with the following specifications (Rubber insulation, type H05RN-F approved by HAR or SAA).

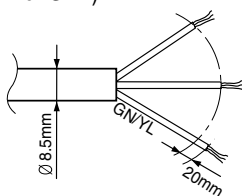

Capacity	1 Phase	3 Phase
18, 24, 30k BTU/h	2.5mm <sup>2</sup>	-
36k BTU/h	5.5mm <sup>2</sup>	2.5mm <sup>2</sup>
48, 54k BTU/h	-	3.5mm <sup>2</sup>

The connecting cable connected to the indoor and outdoor unit should be complied with the following specifications (Rubber insulation, type H05RN-F approved by HAR or SAA).

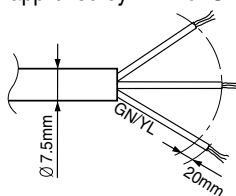

**NORMAL CROSS-SECTIONAL AREA**  
0.75mm<sup>2</sup> (18K/24K/30K)  
1.25mm<sup>2</sup> (36k/48k/45k)

If the supply cord is damaged, it must be replaced by a special cord or assembly available from the manufacturer or its service agent.

### ⚠ WARNING

Make sure that the screws of the terminal are free from looseness.

## 5. Installation of Decoration Panel

The decoration panel has its installation direction.

Before installing the decoration panel, always remove the paper template.

1. Temporarily fix two decoration panel fixing screws (hexagon M5 screw) on the unit body. (Tighten by amount 10mm in length.)  
The fixing screws (hexagon M5 screw) are included the indoor unit box.
2. Remove the air inlet grille from the decoration panel. (Remove the hook for the air inlet grille cord.)
3. Hook the decoration panel key hole (  ) on the screws fixed in step above, and slide the panel so that the screws reach the key hole edge.
4. Retighten completely two temporarily fixed screws and other two screws. (Total 4 screws)
5. Connect the louver motor connector and display connector.
6. After tightening these screws, install the air inlet grille (including the air filter).

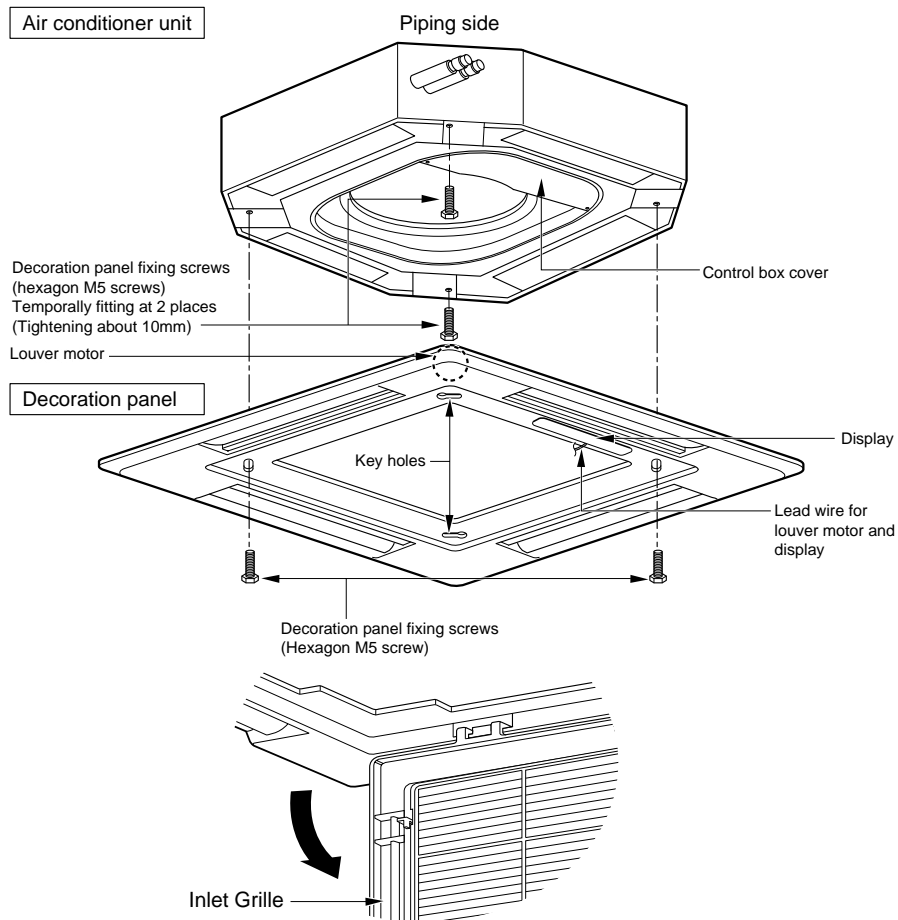

### CAUTION

Install certainly the decoration panel.  
Cool air leakage causes sweating.  
⇒ Water drops fall.

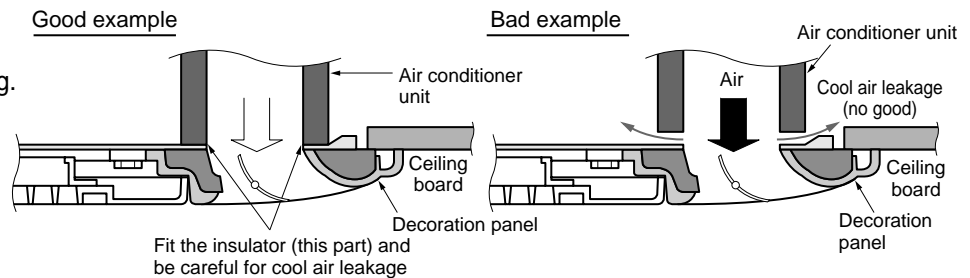

## 6. Heat Insulation and pipings

### HEAT INSULATION

1. Use the heat insulation material for the refrigerant piping which has an excellent heat-resistance (over 120°C).

2. Precautions in high humidity circumstance:

This air conditioner has been tested according to the "KS Standard Conditions with Mist" and confirmed that there is not any default. However, if it is operated for a long time in high humid atmosphere (dew point temperature: more than 23°C), water drops are liable to fall. In this case, add heat insulation material according to the following procedure:

- Heat insulation material to be prepared... Adiabatic glass wool with thickness 10 to 20mm.
- Stick glass wool on all air conditioners that are located in ceiling atmosphere.
- In addition to the normal heat insulation (thickness: more than 8mm) for refrigerant piping (gas piping: thick piping) and drain piping, add further 10mm to 30mm thickness material.

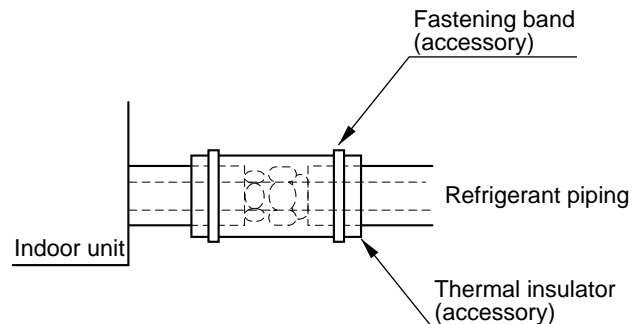

### FORM THE PIPINGS

1. **Wrap the connecting portion of indoor unit with the Insulation material and secure it with two Plastic Bands. (for the right pipings)**

- If you want to connect an additional drain hose, the end of the drain-outlet should be kept at a distance from the ground. (Do not dip it into water, and fix it on the wall to avoid swinging in the wind.)

**In case of the Outdoor unit being installed below position of the Indoor unit.**

2. **Tape the Pipings, drain hose and Connecting Cable from bottom to top.**

3. **Form the pipings gathered by taping along the exterior wall and fix it to the wall by saddle or equivalent.**

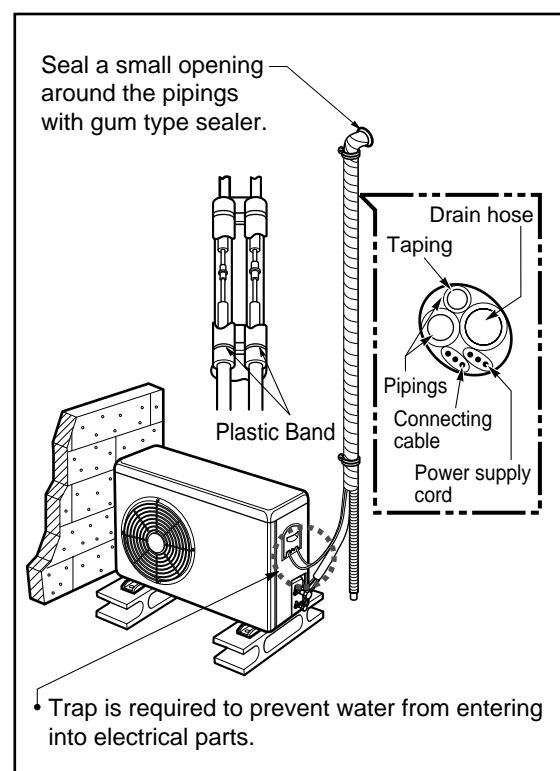

## 7. Drain Pipe Work

### □ Drain pipe gradient and support

- 1) - The drain pipe must be fitted at a gradient of at least 1/100.
  - The drain pipe should be as short as possible and free from airlocks.

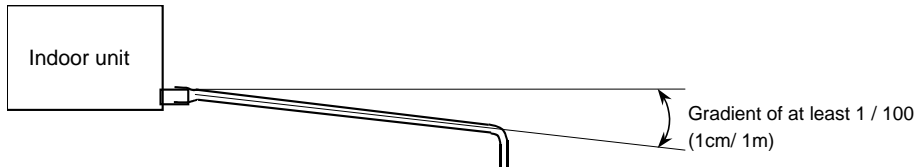

- 2) Suspension bolts should be used to support long stretches of drain pipe in order to ensure that a gradient of 1/100 is maintained. (PVC pipe should not be bent)

### Spacing of supports for horizontal piping

Class	Nominal diameter	Spacing
Rigid PVC pipe	25~40mm	1.0m or less

- 3) The length of pipe laid horizontally should be kept a minimum.

### ■ Drain Piping of Ceiling Cassette

- Drain piping must have down-slope (1/50 to 1/100); be sure not to provide up-and-down slope to prevent reversal flow.
- During drain piping connection, be careful not to exert extra force on the drain port on the indoor unit.
- The outside diameter of the drain connection on the indoor unit is 32mm.

Piping material: Polyvinyl chloride pipe VP-25 and pipe fittings

- Be sure to install heat insulation on the drain piping.

Heat insulation material: Polyethylene foam with thickness more than 8 mm.

- Install the drain raising pipes at a right angle to the indoor unit and no more than 300mm from the unit.

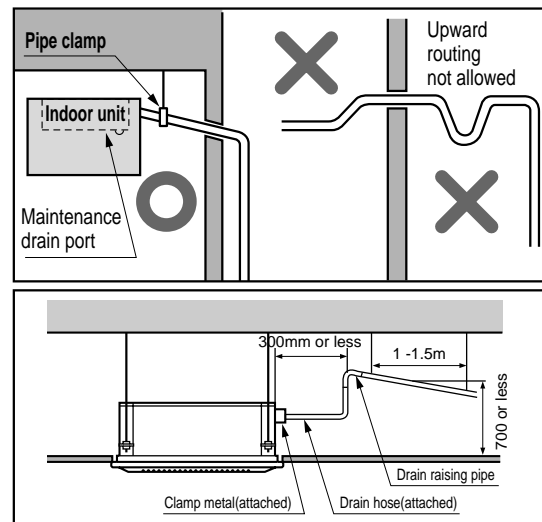

### Drain test

The air conditioner uses a drain pump to drain water. Use the following procedure to test the drain pump operation:

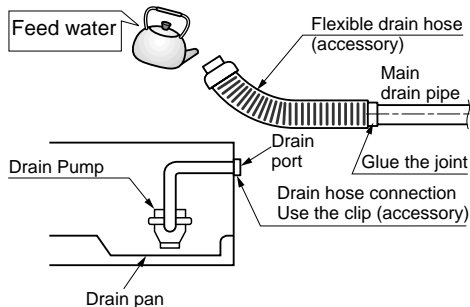

### CAUTION

The supplied flexible drain hose should not be curved, neither screwed. The curved or screwed hose may cause a leakage of water.

- Connect the main drain pipe to the exterior and leave it provisionally until the test comes to an end.
- Feed water to the flexible drain hose and check the piping for leakage.
- Be sure to check the drain pump for normal operating and noise when electrical wiring is complete.
- When the test is complete, connect the flexible drain hose to the drain port on the indoor unit.

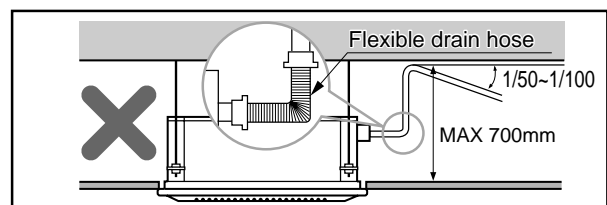

■ Drain Piping of Ceiling Concealed Duct

**CAUTION**

1. **Decline Installation** of indoor unit is very **important for the drain** of the duct type air conditioner.
2. Minimum thickness of the insulation for the connecting pipe should be 5mm.

**Front of view**

- The unit must be or declined to wards drain hose while installation.

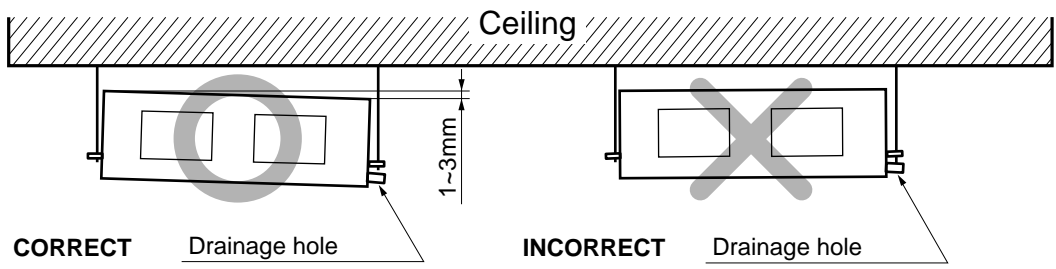

**CAUTION FOR GRADIENT OF UNIT AND DRAIN PIPING**

Lay the drain hose with a downward inclination so water will drain out.

- Always lay the drain with downward inclination (1/50 to 1/100). Prevent any upward flow or reverse flow in any part.
- 5mm or thicker formed thermal insulator shall always be provided for the drain pipe.

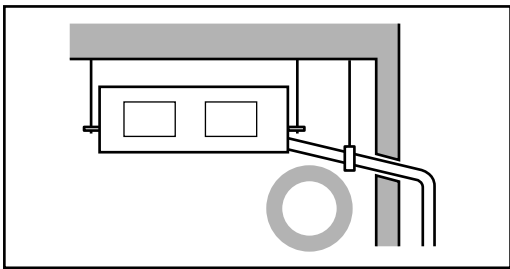
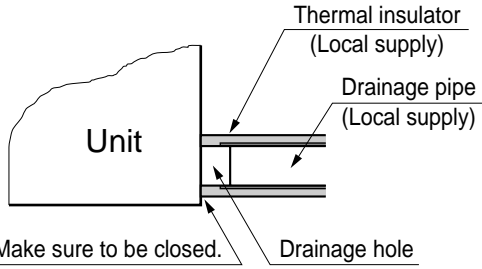

- CORRECT**
- Install the P-Trap (or U-Trap) to prevent a water leakage caused by the blocking of intake air filter.

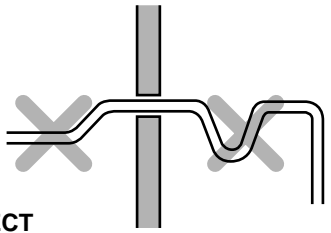

**INCORRECT Applied U-Trap Dimension**

- A ≥ 70mm
- B ≥ 2C
- C ≥ 2 x SP
- SP = External Pressure (mmAq)
- Ex) External Pressure = 10mmAq
- A ≥ 70mm
- B ≥ 40mm
- C ≥ 20mm

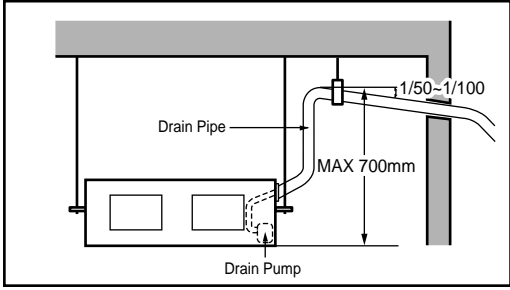
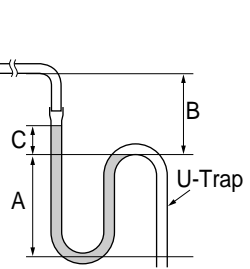

## ■ Grouped drain piping

- 1) It is standard work practice to make connections to the main pipe from above. The pipe coming down from the combination should be as large as possible.

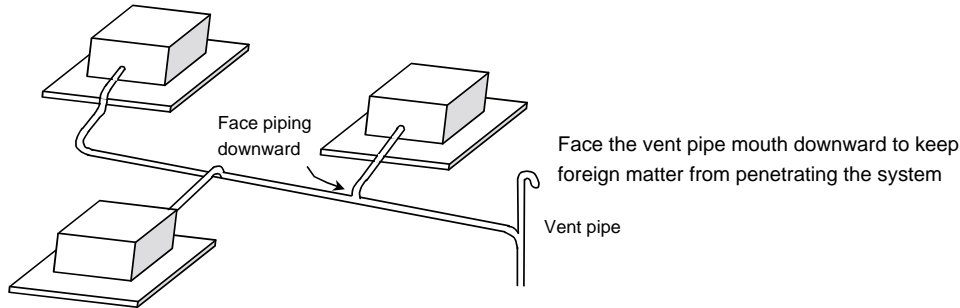

- 2) The pipe work should be kept as short as possible and the number of indoor units per group kept to a minimum.

## 8. Optional Operation

### 1) Two Thermistor System(Ceiling Cassette/ceiling Concealed duct model)

- (1) Open the rear cover of the wired remote-controller to set the mode.
  - (2) Select one of three selectable modes as follows.
    - Position 1:  
The room temperature is controlled by the thermistor of the main body.
    - Position 2:  
The room temperature is controlled by the thermistor of the wired remote-controller, control the temperature according to the position of wired remote-controller.
    - Position 3:  
The room temperature is controlled by lower temperature between the temperature of main body and of remote-controller sensor.
- (3) Move the slide switch to set position.

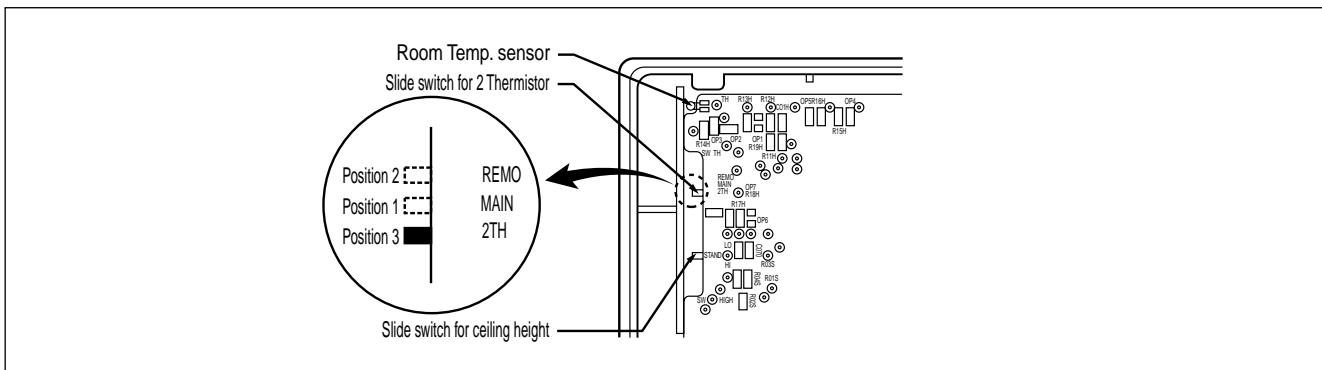

- (4) Close the rear cover and check if it works normally.

### ⚠ CAUTION

- Select the position after counselling with a customer.
- In case of cooling mode, room temperature is controlled by the main body sensor.
- To control the room temperature by a wired remote controller, install controller(room temp. sensor) to sense the temperature more accurately.
- Manufactured in the position 3.



## 2) Adjusting air volume to the height of ceiling(Ceiling Cassette model)

You can choose the RPM(or air volume) of indoor motor according to the height of ceiling to supply the comfortable atmosphere to consumers.

### Procedure

1. Choose the selectable position in the table after measuring the height of ceiling.

Ceiling height	Mode of slide switch	Change of air volume	Remark
more than 3.3m	High Ceiling	Increasing	Manufactured in standard mode
2.7~3.3m	Standard	-	
less than 2.7m	Low Ceiling	Decreasing	

2. In the case of changing the height as "high" or "low", open the rear cover of the wired remote-controller.

3. Move the slide switch to the set position.

4. Close the rear cover and check if it works normally.

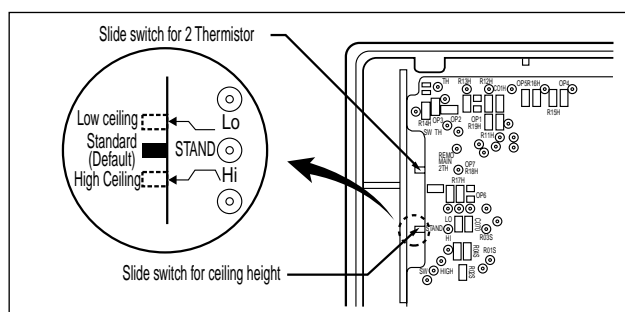

## 3) Group Control(Ceiling Cassette/Ceiling Concealed duct model)

It operates maximum 16 Units by only one Wired Remote Controller, and each Unit starts sequentially to prevent overcurrent.

### Wiring design

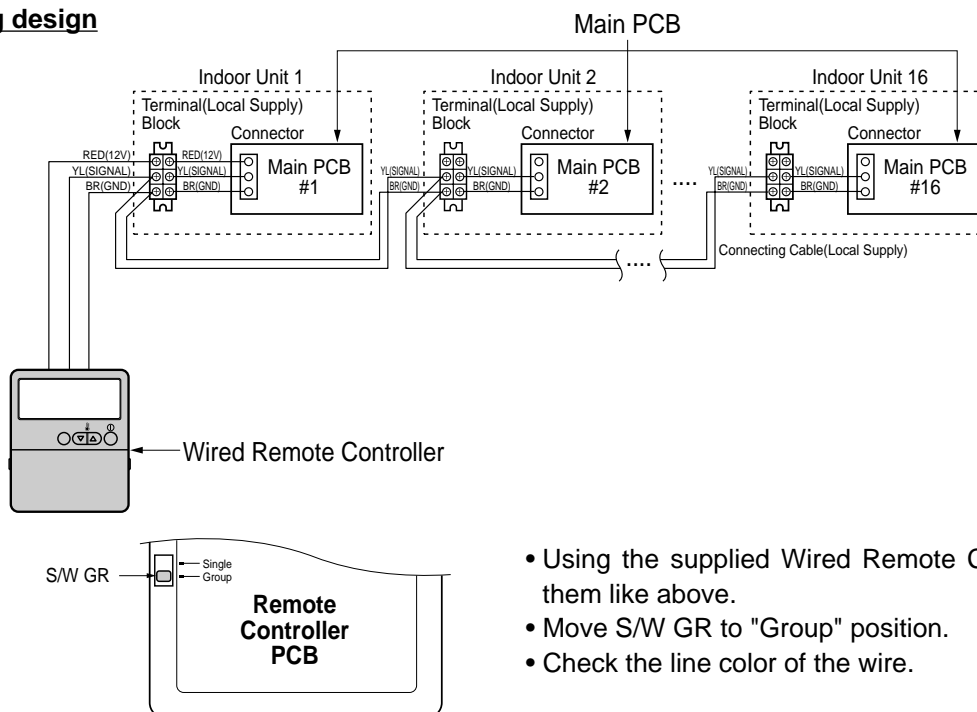

- Using the supplied Wired Remote Controller, wire them like above.
- Move S/W GR to "Group" position.
- Check the line color of the wire.

### CAUTION

- Be careful not to exchange the color of wires.
- The maximum length of connecting wire should be below 200m(25Ω) on connecting each units.
- Use a wire more than 0.5mm<sup>2</sup>

## 9. Plasma Air Cleaner(Ceiling concealed duct model)

### 1) Safety First

- Cut off the power supply before installation and maintenance.
- Plasma air-cleaner must be installed at safe area where it is far away from the user.
- Plasma air-cleaner must be installed at appointed location.
  - All wiring and connections are for installation only.

### 2) Attention

- Exchange the existing remote controller with an enclosed new remote controller while installing.
- Be sure to turn off the power before removing the air cleaner unit for washing.

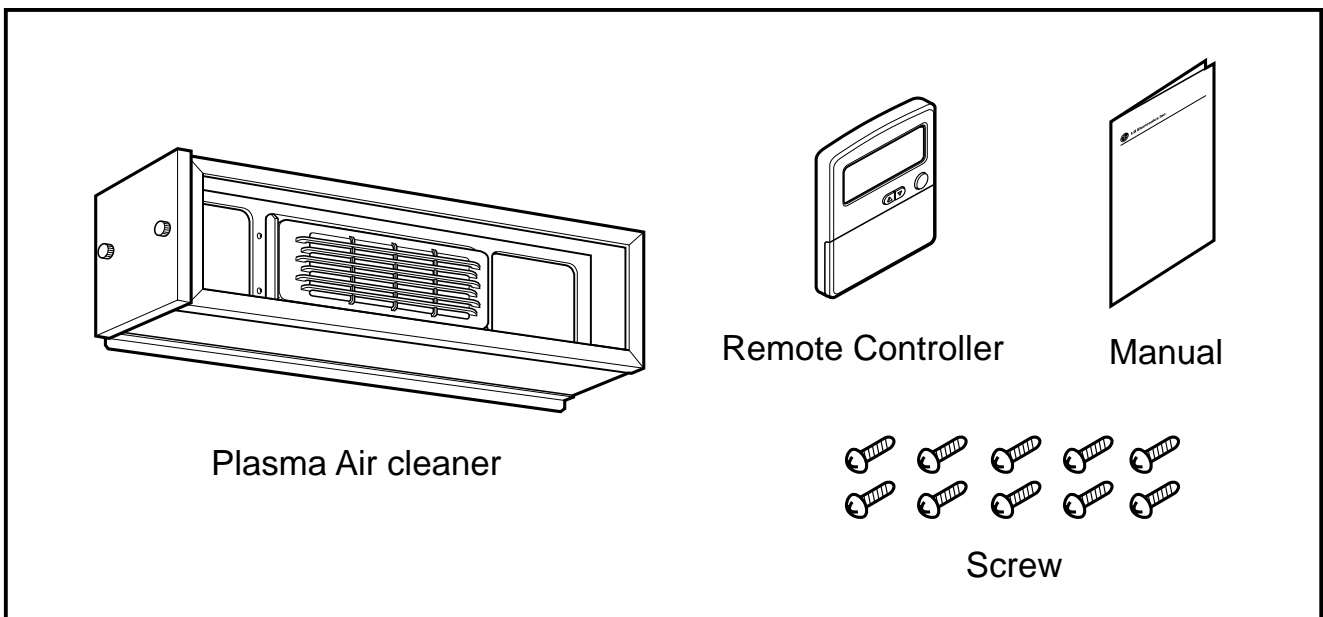

### 3) Quantity

<u>Quantity</u>	<u>Package contents</u>
1	Plasma Air-cleaner
10	Screw
1	wired Remote-controller
1	Installation manual

## 4) How to install

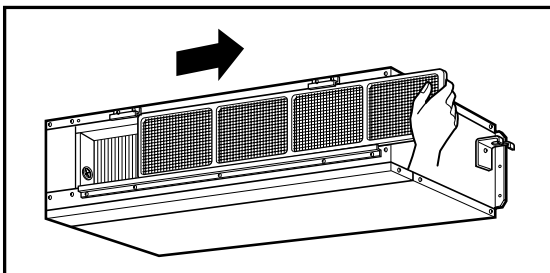

1. Remove the filter.

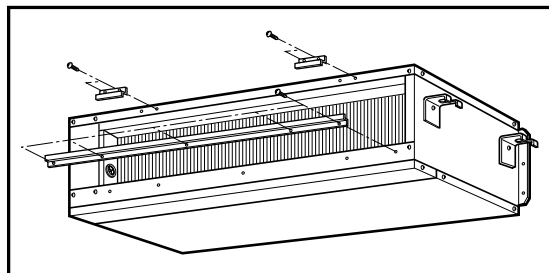

2. Remove the three brackets from the indoor unit.

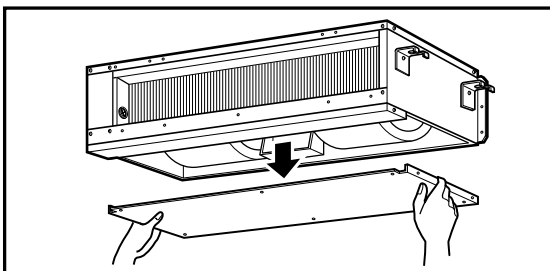

3. Open the rear panel.

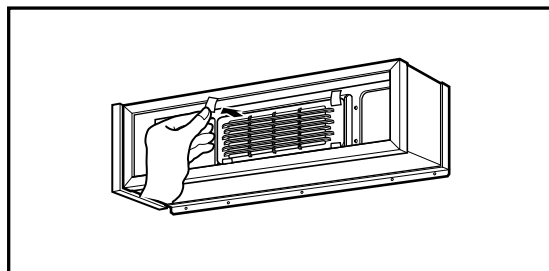

4. Remove all the tapes.

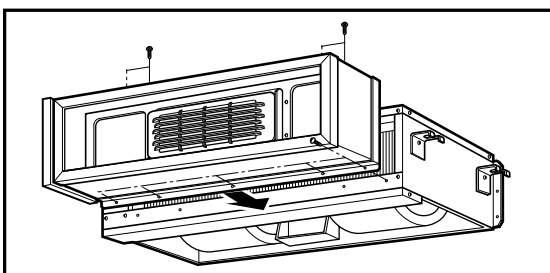

5. Assemble the air cleaner.

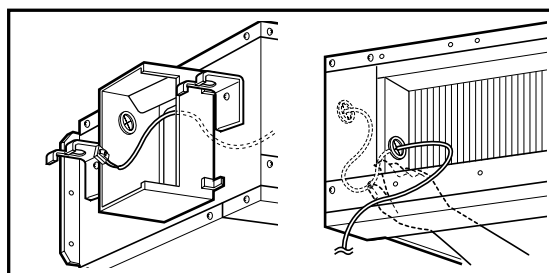

6. Connect the lead wire to control box through the bushings.

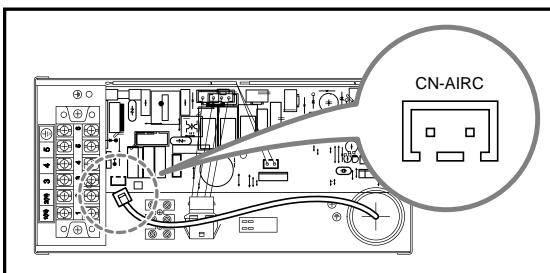

7. The location of connecting terminal.

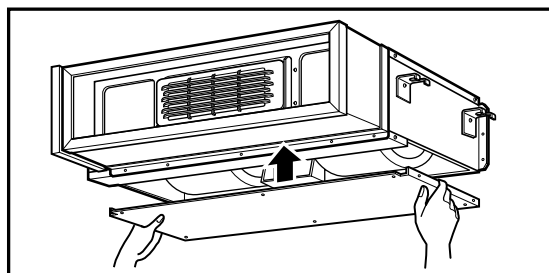

8. Assemble the rear panel.

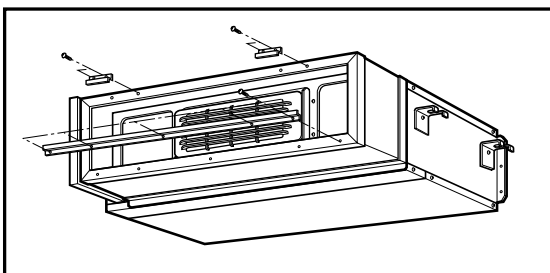

9. Assemble the three brackets to the air cleaner.

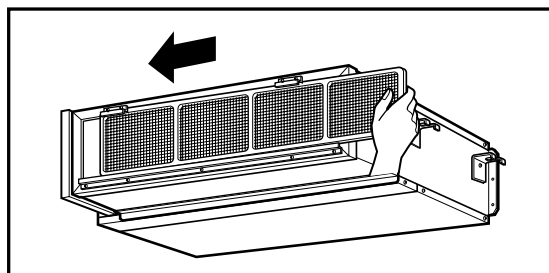

10. Insert the filter.

### 5) How to maintain

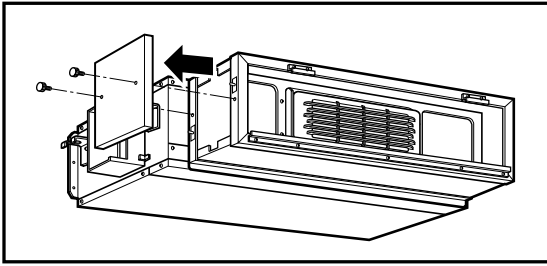

1. Remove the side panel.

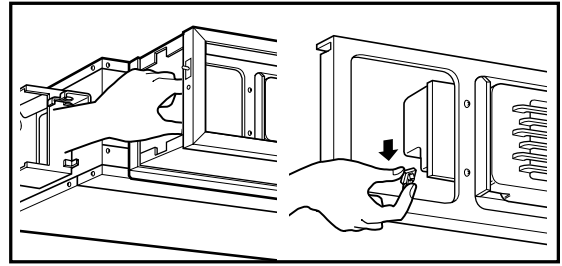

2. Disconnect the lead wire.

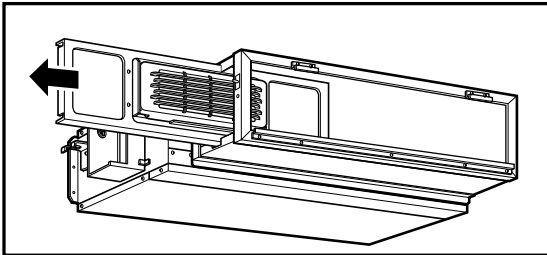

3. Pull the sliding bracket.

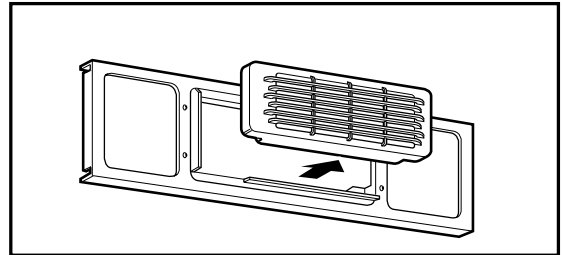

4. Remove the air cleaner kit.

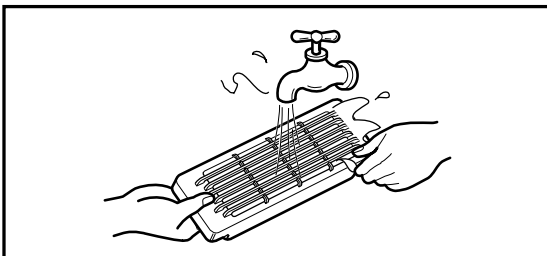

5. Wash the air cleaner kit.

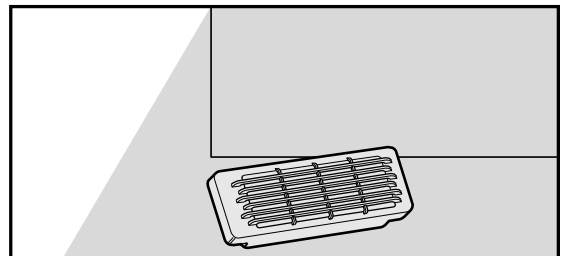

6. Dry the air cleaner kit in a shaded lot until all the water become dry up completely.

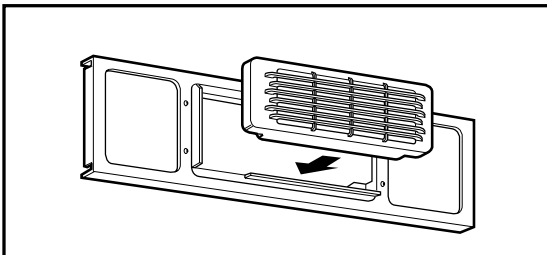

7. Assemble the air cleaner.

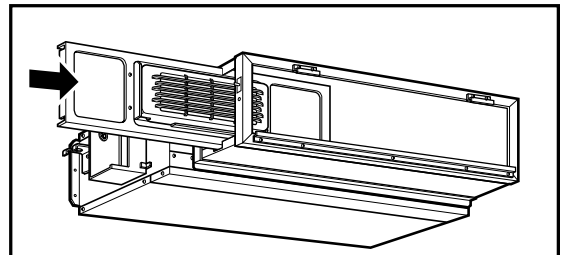

8. Insert the sliding bracket.

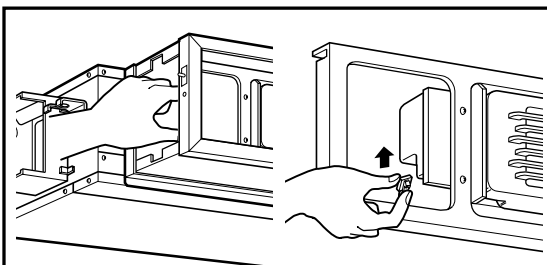

9. Connect the lead wire.

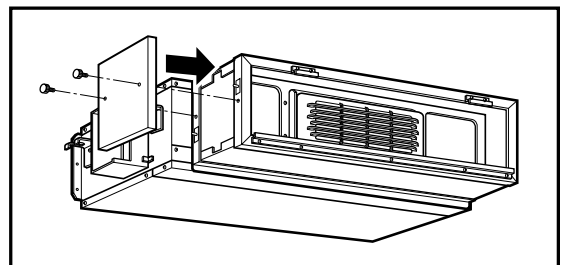

10. Assemble the side panel.

### 6) Service Parts List

No.	Location No.	P/No.	Description	Remark
1	159830	5983A10003C	Air cleaner kit	
2	266090	6609A10002A	H.V Assembly	
3	267110	6871A10008F	Remote Controller	ABPAHH
		6871A10008G		ABPAHC
		6871A10008F		ABPAGH
		6871A10008G		ABPAGC
		6871A10008D		ABPAEH
		6871A10008C		ABPAEC
		6871A10008E		ABPAEZ

### 7) Dimension

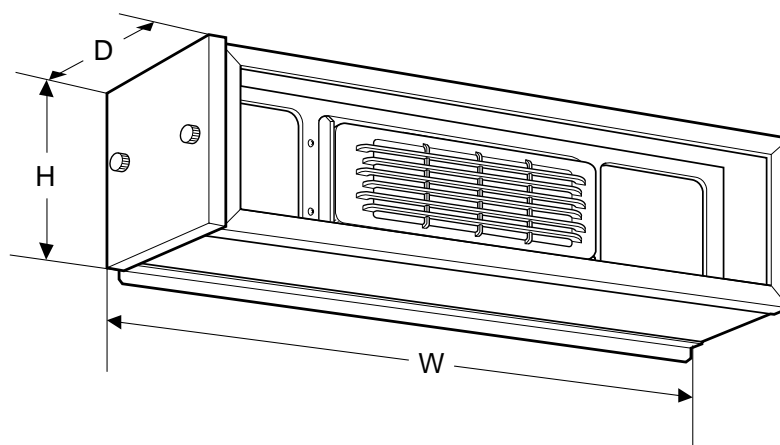

Model	Dimension (mm)		
	H	D	W
ABPAHH	230	180	785
ABPAHC			
ABPAGH	260	180	1092
ABPAGC			
ABPAEH	350	180	1235
ABPAEC			
ABPAEZ			





Ceiling & Floor

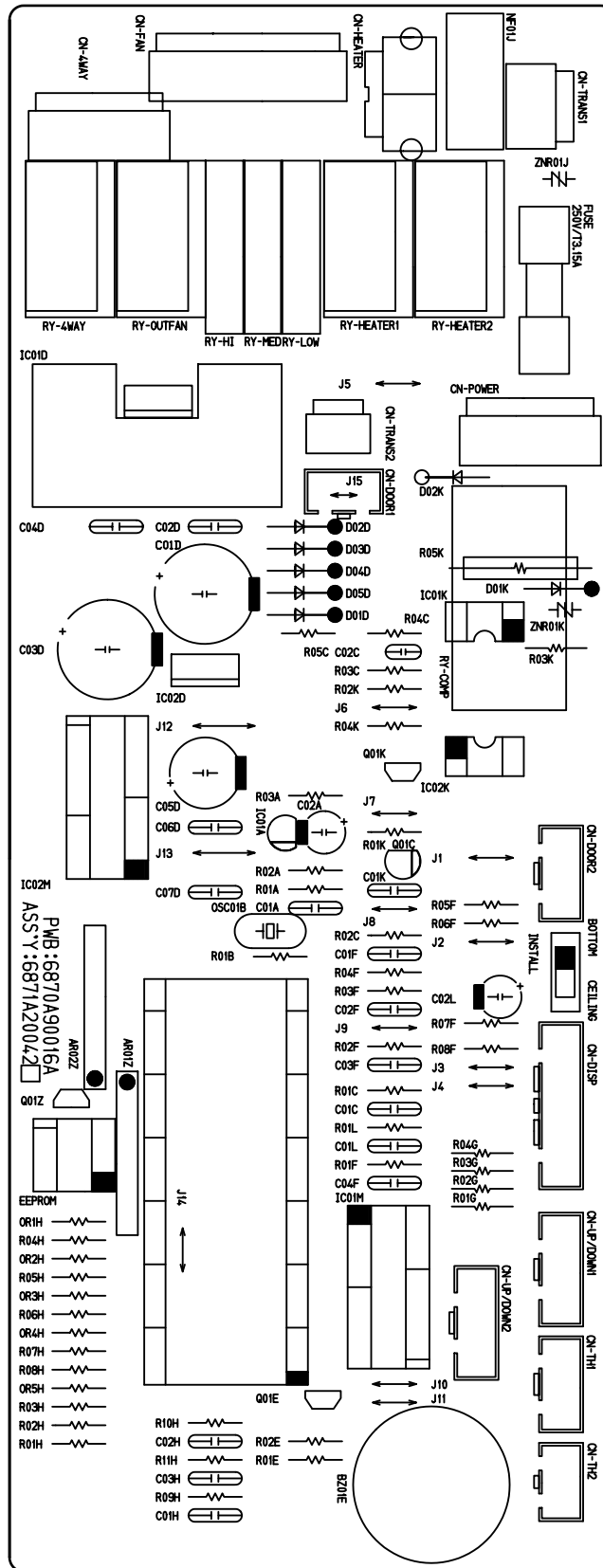



# Schematic Diagram

## Ceiling Cassette Type

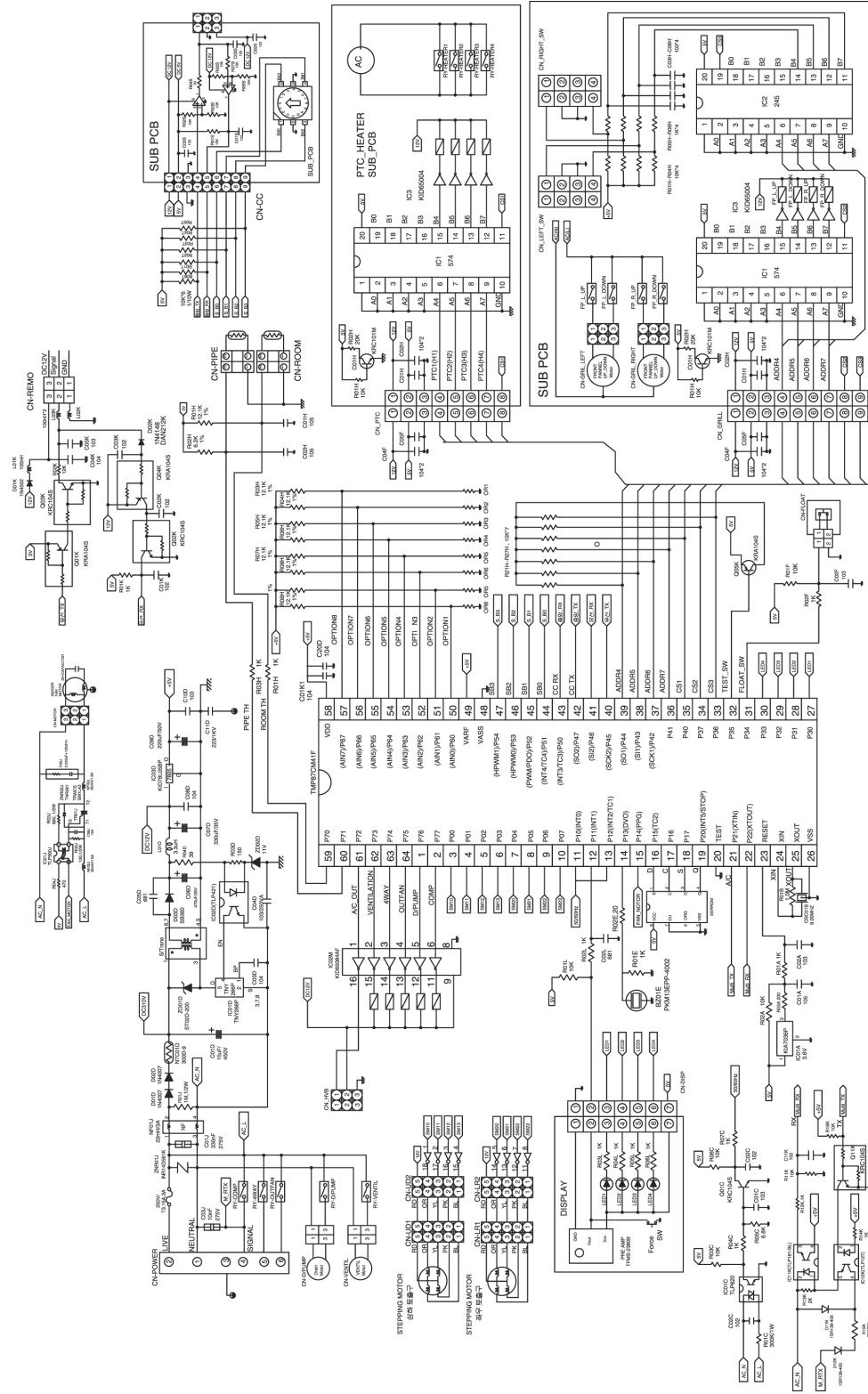

Ceiling Duct Type(BG Series)

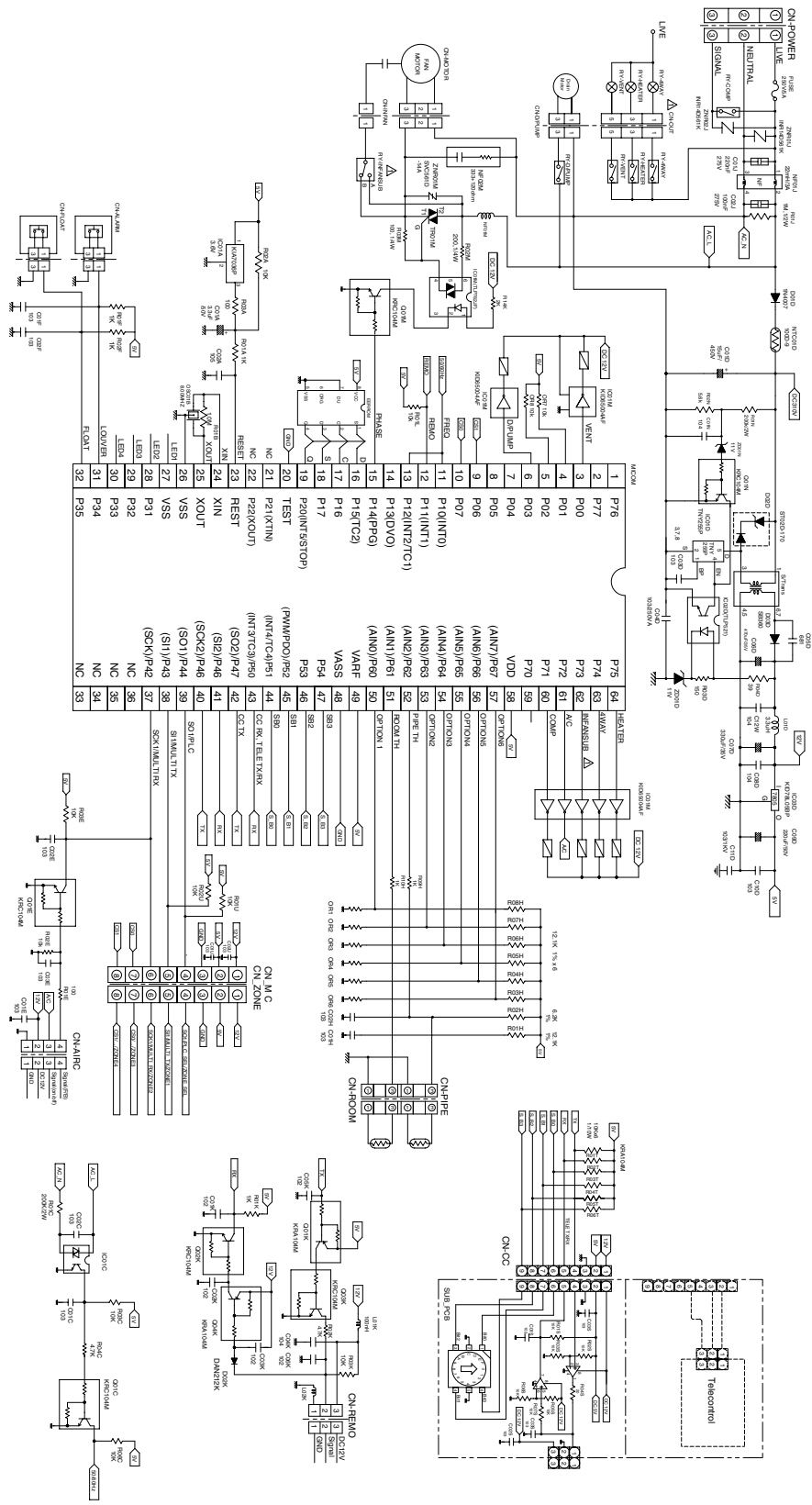

Ceiling Duct Type(BH, BE Series)

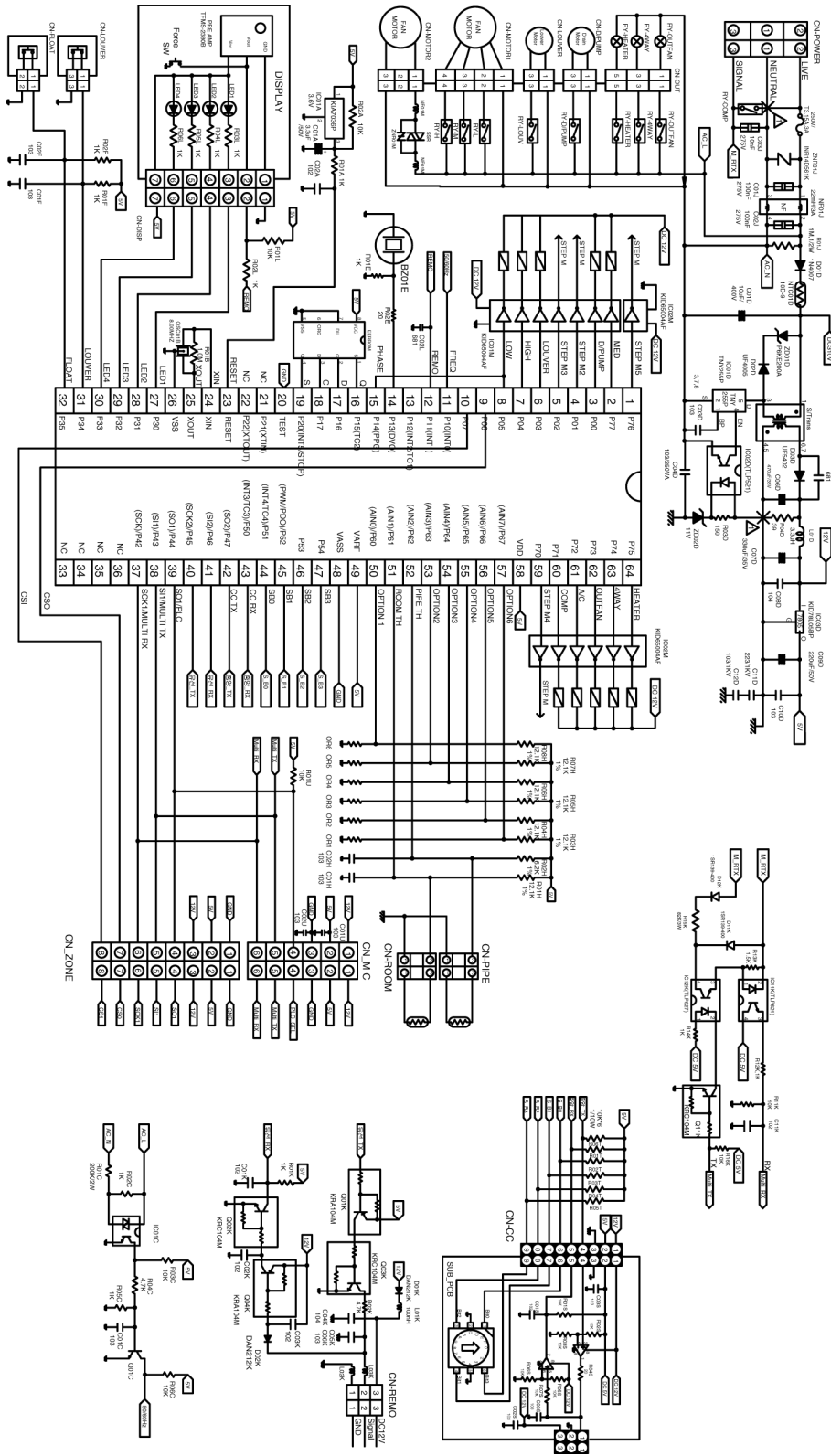

Ceiling & Floor

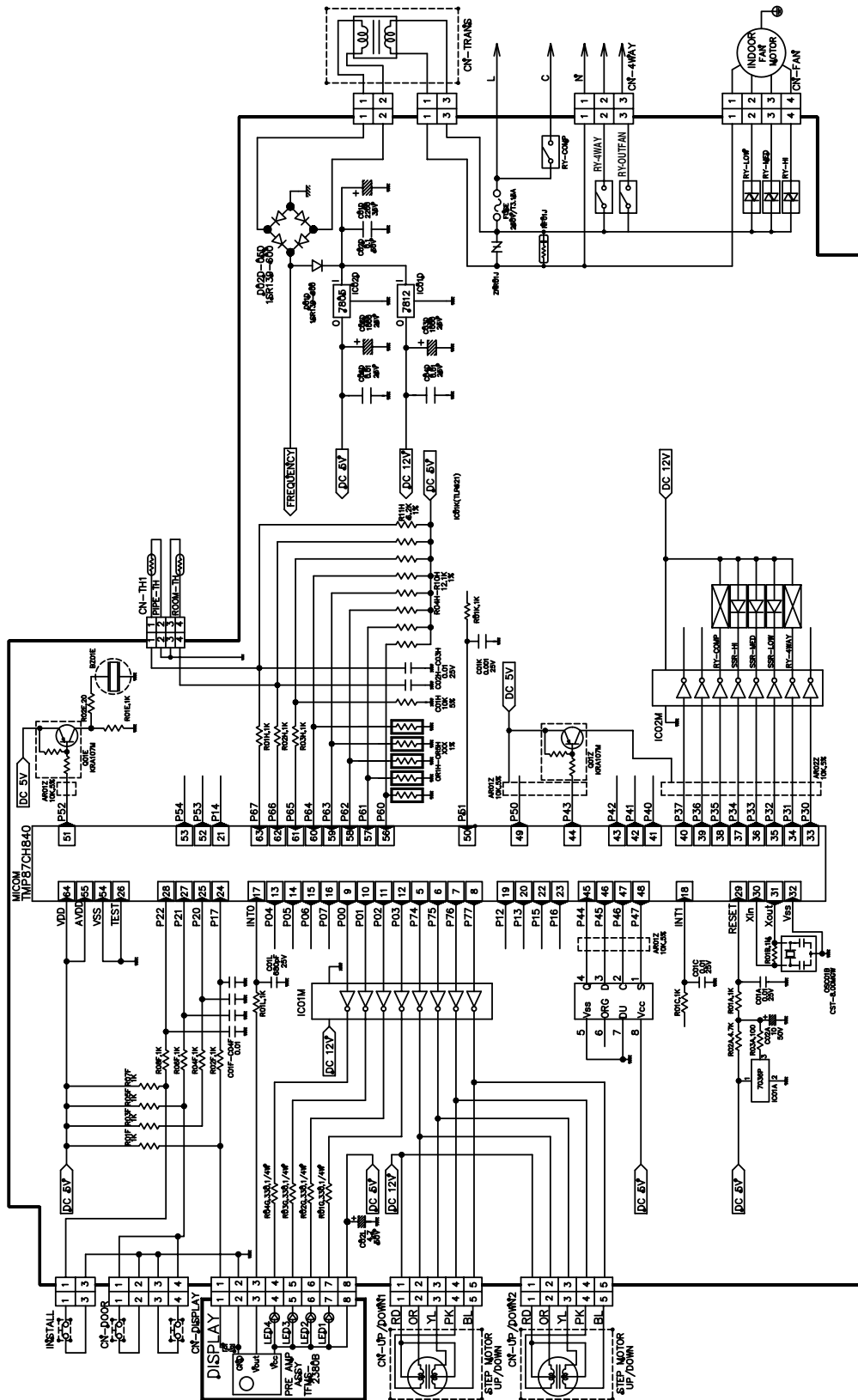

# Exploded View and Replacement Parts List

## 1. Indoor Unit

### Ceiling Cassette Type

#### ATNC-EL, ATNH-EL

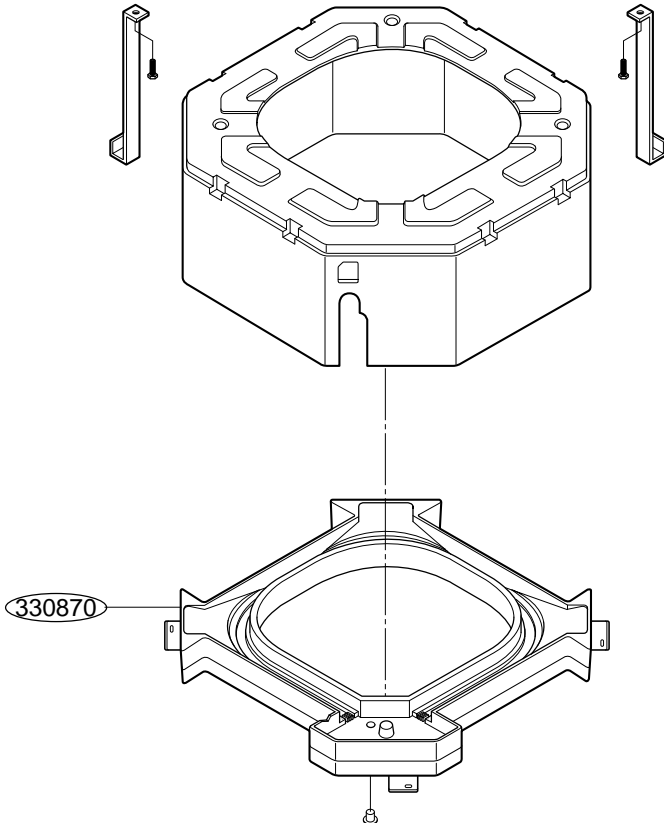
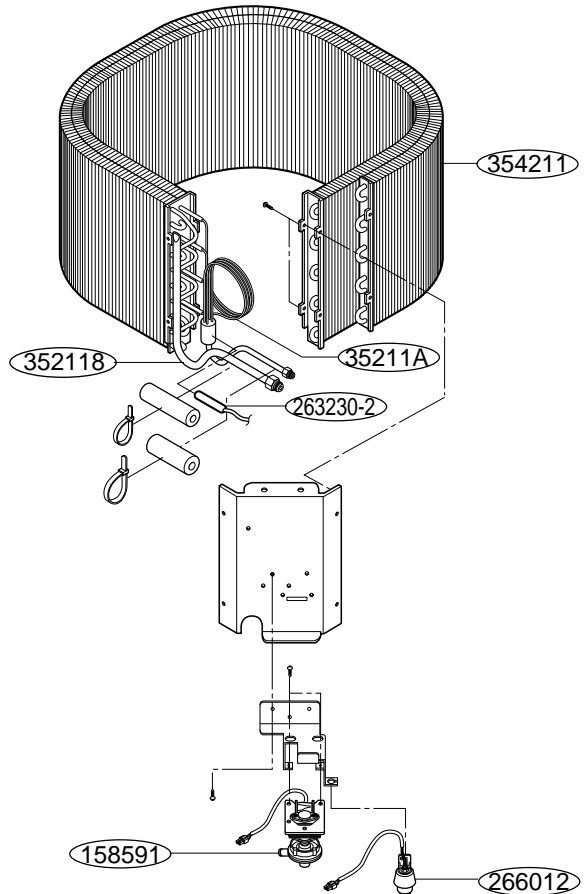
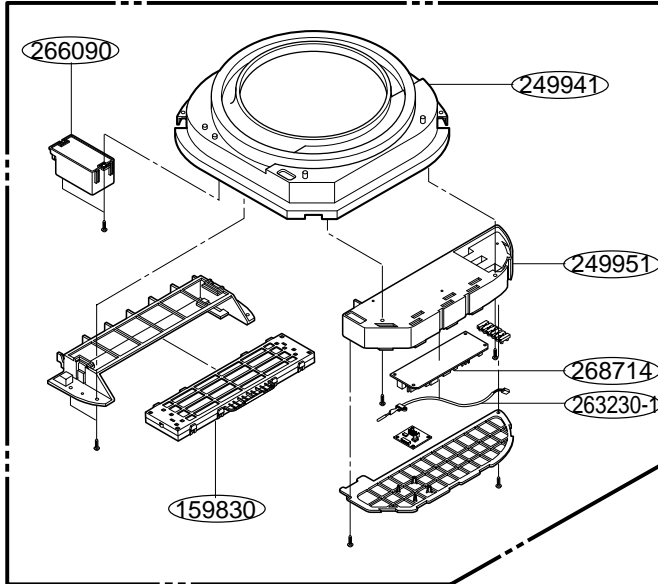

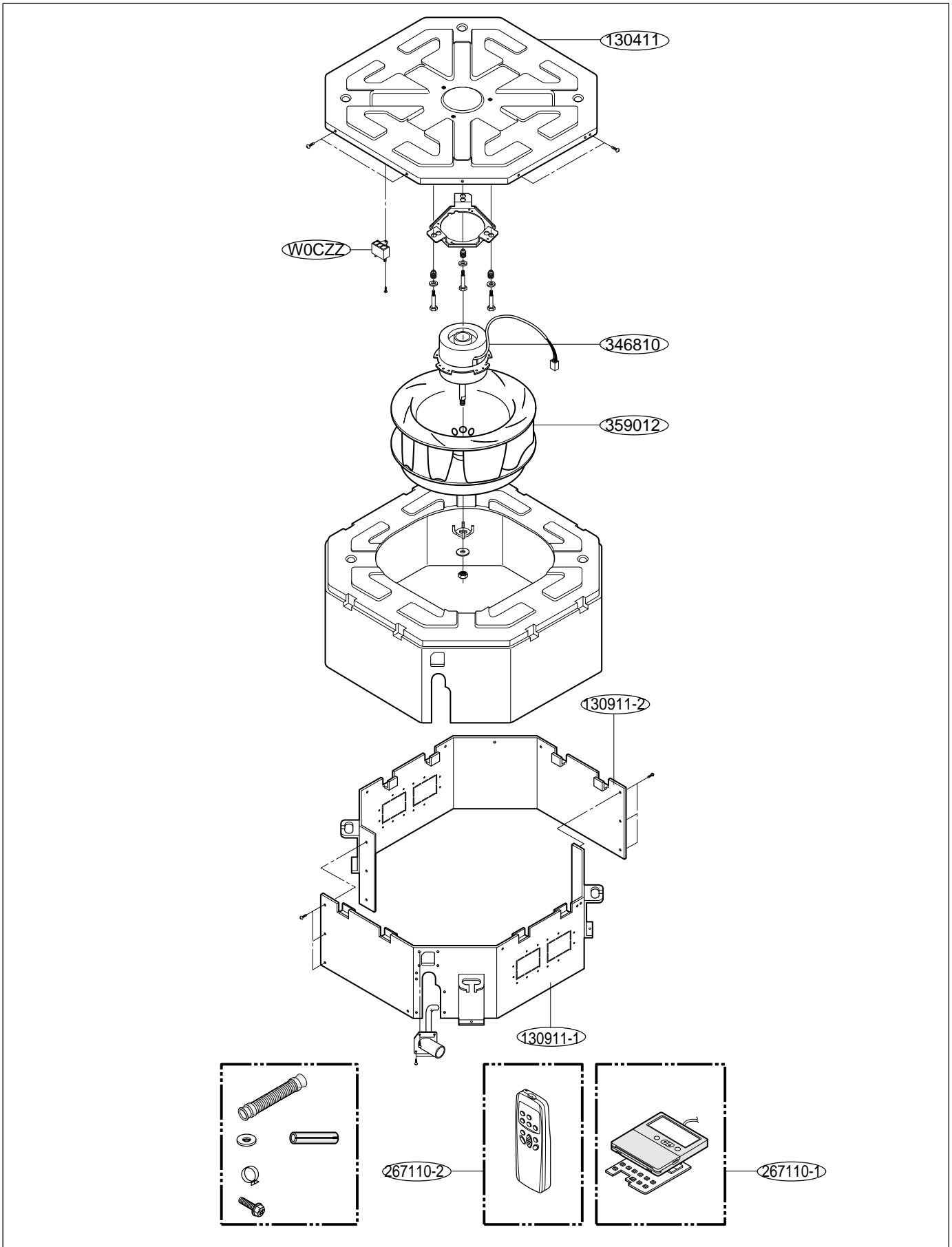

## Parts List

LOCATION No.	DESCRIPTION	Part No.				REMARKS
		ATNC186ELAA	ATC186ELCA	ATNH186ELAA	ATNH186ELCA	
130411	BASE ASSY,WELD(INDOOR)	3041A10013A	3041A10013A	3041A10013A	3041A10013A	R
130911-1	CABINET ASSEMBLY,INDOOR	3091A10023C	3091A10023C	3091A10023C	3091A10023C	R
130911-2	CABINET ASSEMBLY,INDOOR	3091A10023D	3091A10023D	3091A10023D	3091A10023D	R
158591	PUMP ASSEMBLY,WATER	5859A20001M	5859A20001M	5859A20001M	5859A20001M	R
159830	AIR CLEANER ASSEMBLY	-	5983A10002A	-	5983A10002A	R
249941	CONTROL BOX ASSEMBLY,INDOOR	4994A10014A	4995A20168B	4994A10014A	4995A20168B	R
249951	CONTROL BOX ASSEMBLY,INDOOR	4995A14001B	4995A14001B	4995A14001A	4995A14001A	R
263230-1	THERMISTOR ASSEMBLY	6323AQ3226F	6323AQ3226F	6323AQ3226F	6323AQ3226F	R
263230-2	THERMISTOR ASSEMBLY	6323AQ3226F	6323AQ3226F	6323AQ3226F	6323AQ3226F	R
266012	SWITCH ASSY,FLOAT	6601A20001G	6601A20001G	6601A20001G	6601A20001G	R
266090	H.V ASSY	-	6609A20005C	-	6609A20005C	R
267110	REMOTE CONTROLLER ASSEMBLY	6711A20039G	6711A20039J	6711A20039H	6711A20039K	R
267110	REMOTE CONTROLLER ASSEMBLY	-	6711A20076K	-	6711A20076J	R
330870	DRAIN PAN ASSEMBLY	3087A10002A	3087A10002A	3087A10002A	3087A10002A	R
346810	MOTOR ASSY,SINGLE	4681AC2026D	4681AC2026D	4681AC2026D	4681AC2026D	R
35211A	TUBE ASSEMBLY,SUCTION INDOOR	5211A20243L	5211A20243L	5211A20243L	5211A20243L	R
354211	EVAPORATOR ASSEMBLY,BENDING	5421A10006E	5421A10006E	5421A10006E	5421A10006E	R
359011	FAN,TURBO	5900A10004A	5900A10004A	5900A10004A	5900A10004A	R
552118	TUBE ASSEMBLY,MENIFOLD(INDOOR)	5211A20241F	5211A20241F	5211A20241F	5211A20241F	R
W0CZZ	CAPACITOR,DRAWING	3H00660N	3H00660N	3H00660N	3H00660N	R

Ceiling Cassette Type

ATNC-FL, ATNH-FL

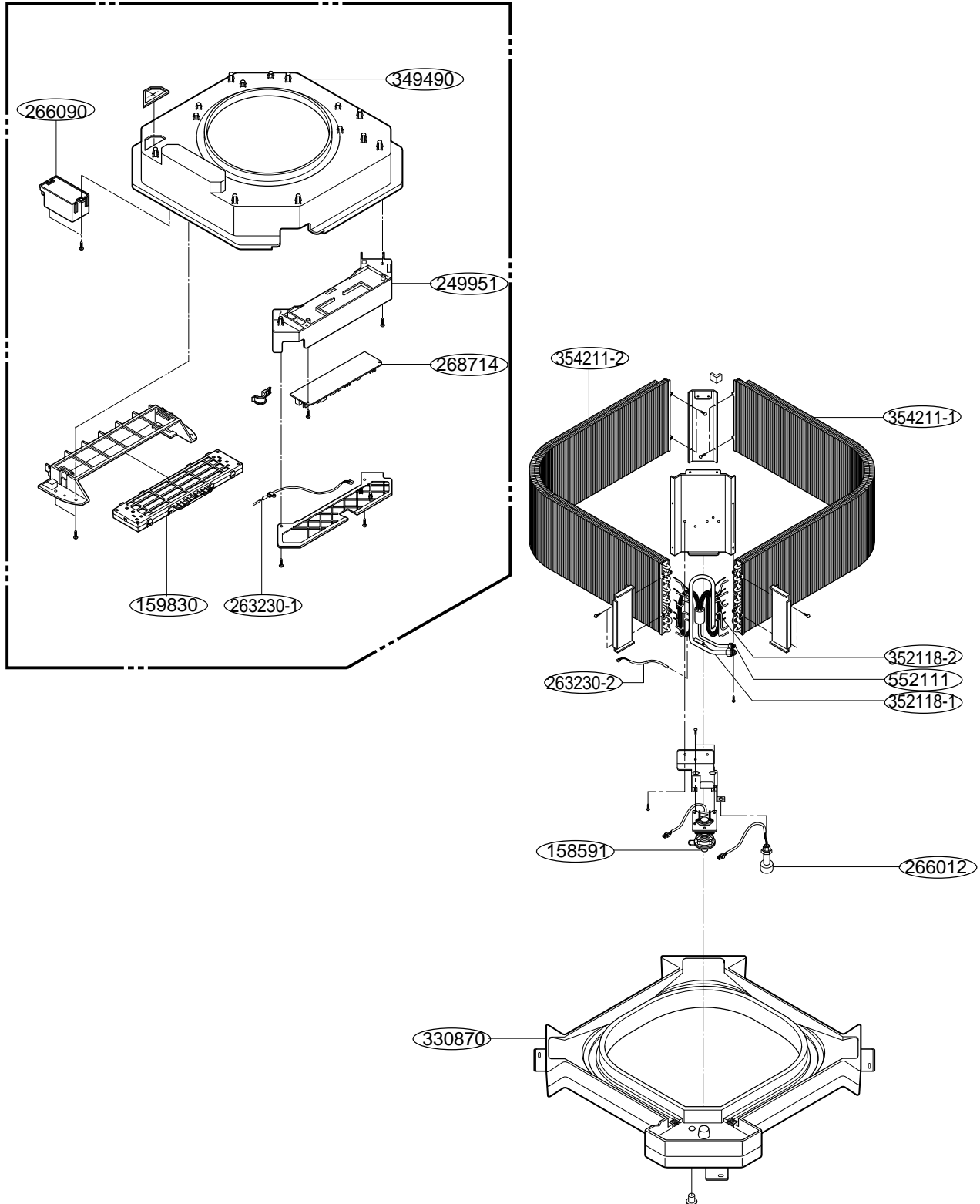



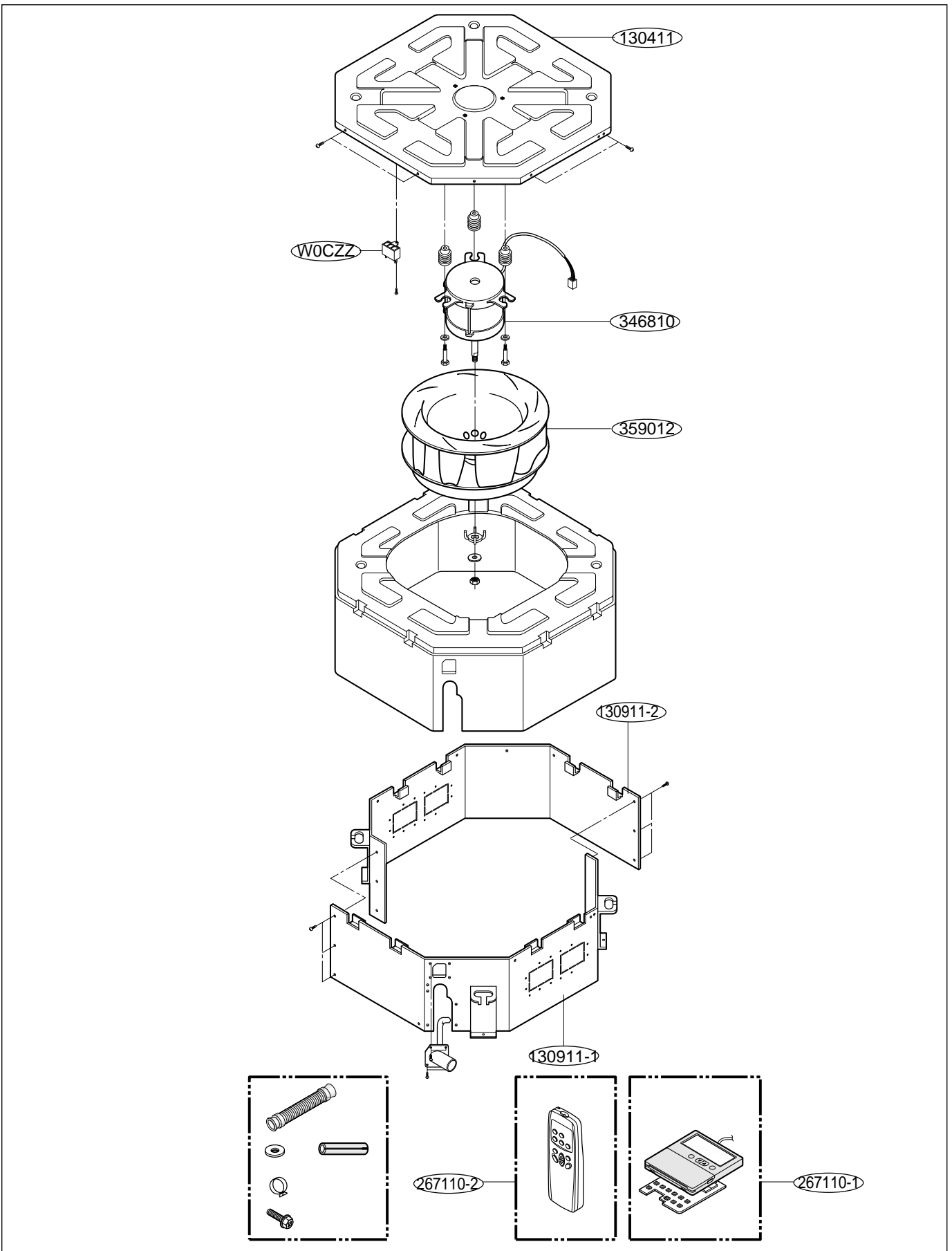

## Parts List

LOCATION No.	DESCRIPTION	Part No.				REMARKS
		ATNC246FLAA	ATNC246FLCA	ATNH246FLAA	ATNH246FLCA	
130411	BASE ASSEMBLY,WELD[INDOOR]	3041A10030B	3041A10030B	3041A10030B	3041A10030B	R
130911	CABINET ASSEMBLY,INDOOR	3091A10051A	3091A10051A	3091A10051A	3091A10051A	R
130911	CABINET ASSEMBLY,INDOOR	3091A10051B	3091A10051B	3091A10051B	3091A10051B	R
158591	PUMP ASSEMBLY,WATER	5859A20001K	5859A20001K	5859A20001K	5859A20001K	R
159830	AIR CLEANER ASSEMBLY	-	5983A10002A	-	5983A10002A	R
249951	CONTROL BOX ASSEMBLY,INDOOR	4995A10093F	4995A10093F	4995A10093C	4995A10093C	R
263230-1	THERMISTOR ASSEMBLY	6323AQ3226E	6323AQ3226E	6323AQ3226E	6323AQ3226E	R
263230-2	THERMISTOR ASSEMBLY	6323AQ3226E	6323AQ3226E	6323AQ3226E	6323AQ3226E	R
266012	SWITCH ASSEMBLY,FLOAT	6601A20001H	6601A20001H	6601A20001H	6601A20001H	R
266090	H.V ASSEMBLY	-	6609A20005E	-	6609A20005E	R
267110	REMOTE CONTROLLER ASSEMBLY	6711A20039G	6711A20039J	6711A20039H	6711A20039K	R
267110	REMOTE CONTROLLER ASSEMBLY	-	6711A20076K	-	6711A20076J	R
268714	PWB(PCB) ASSEMBLY,MAIN	6871A10105G	6871A10105G	6871A10105F	6871A10105F	R
330870	DRAIN PAN ASSEMBLY	3087A10010B	3087A10010B	3087A10010B	3087A10010B	R
346810	MOTOR ASSEMBLY,INDOOR	4681A20051Z	4681A20051Z	4681A20051Z	4681A20051Z	R
349490	ORIFICE ASSEMBLY	4949A10007A	4949A10007B	4949A10007A	4949A10007B	R
352118	TUBE ASSEMBLY,MENIFOLD(INDOOR)	5211A20251K	5211A20251K	5211A20251K	5211A20251K	R
352118	TUBE ASSEMBLY,MENIFOLD(INDOOR)	5211A20251L	5211A20251L	5211A20251L	5211A20251L	R
354211	EVAPORATOR ASSEMBLY,BENDING	5421A10016G	5421A10016G	5421A10016G	5421A10016G	R
354211	EVAPORATOR ASSEMBLY,BENDING	5421A10016H	5421A10016H	5421A10016H	5421A10016H	R
359012	FAN ASSEMBLY,TURBO	5901A10036A	5901A10036A	5901A10036A	5901A10036A	R
552111	TUBE ASSEMBLY,CAPILLARY	5211A21137A	5211A21137A	5211A21137A	5211A21137A	R
W0CZZ	CAPACITOR,DRAWING	3H00660M	3H00660M	3H00660M	3H00660M	R

## Parts List

LOCATION No.	DESCRIPTION	Part No.				REMARKS
		ATNC306FLAA	ATNC306FLCA	ATNH306FLAA	ATNH306FLCA	
130411	BASE ASSEMBLY,WELD[INDOOR]	3041A10030B	3041A10030B	3041A10030B	3041A10030B	R
130911	CABINET ASSEMBLY,INDOOR	3091A10051A	3091A10051A	3091A10051A	3091A10051A	R
130911	CABINET ASSEMBLY,INDOOR	3091A10051B	3091A10051B	3091A10051B	3091A10051B	R
158591	PUMP ASSEMBLY,WATER	5859A20001K	5859A20001K	5859A20001K	5859A20001K	R
266012	SWITCH ASSEMBLY,FLOAT	6601A20001H	6601A20001H	6601A20001H	6601A20001H	R
159830	AIR CLEANER ASSEMBLY	-	5983A10002A	-	5983A10002A	R
266090	H.V ASSEMBLY	-	6609A20005E	-	6609A20005E	R
249951	CONTROL BOX ASSEMBLY,INDOOR	4995A10093J	4995A10093J	4995A10093G	4995A10093G	R
249951	CONTROL BOX,INDOOR	4994A10041A	4994A10041A	4994A10041A	4994A10041A	R
263230-1	THERMISTOR ASSEMBLY	6323AQ3226E	6323AQ3226E	6323AQ3226E	6323AQ3226E	R
263230-2	THERMISTOR ASSEMBLY	6323AQ3226E	6323AQ3226E	6323AQ3226E	6323AQ3226E	R
267110	REMOTE CONTROLLER ASSEMBLY	-	6711A20039J	-	6711A20039K	R
267110	REMOTE CONTROLLER ASSEMBLY	6711A20076B	6711A20076K	6711A20076A	6711A20076J	R
330870	DRAIN PAN ASSEMBLY	3087A10010B	3087A10010B	3087A10010B	3087A10010B	R
346810	MOTOR ASSEMBLY,INDOOR	4681A20051W	4681A20051W	4681A20051W	4681A20051W	R
349490	ORIFICE ASSEMBLY	4949A10007A	4949A10007B	4949A10007A	4949A10007B	R
354211	EVAPORATOR ASSEMBLY,BENDING	5421A10016G	5421A10016G	5421A10016G	5421A10016G	R
354211	EVAPORATOR ASSEMBLY,BENDING	5421A10016H	5421A10016H	5421A10016H	5421A10016H	R
552111	TUBE ASSEMBLY,CAPILLARY	5211A21137A	5211A21137A	5211A21137A	5211A21137A	R
352118	TUBE ASSEMBLY,MENIFOLD(INDOOR)	5211A20251K	5211A20251K	5211A20251K	5211A20251K	R
352118	TUBE ASSEMBLY,MENIFOLD(INDOOR)	5211A20251L	5211A20251L	5211A20251L	5211A20251L	R
359012	FAN ASSEMBLY,TURBO	5901A10036A	5901A10036A	5901A10036A	5901A10036A	R
W0CZZ	CAPACITOR,DRAWING	3H00660M	3H00660M	3H00660M	3H00660M	R

Ceiling Cassette Type

ATNC-DL, ATNH-DL

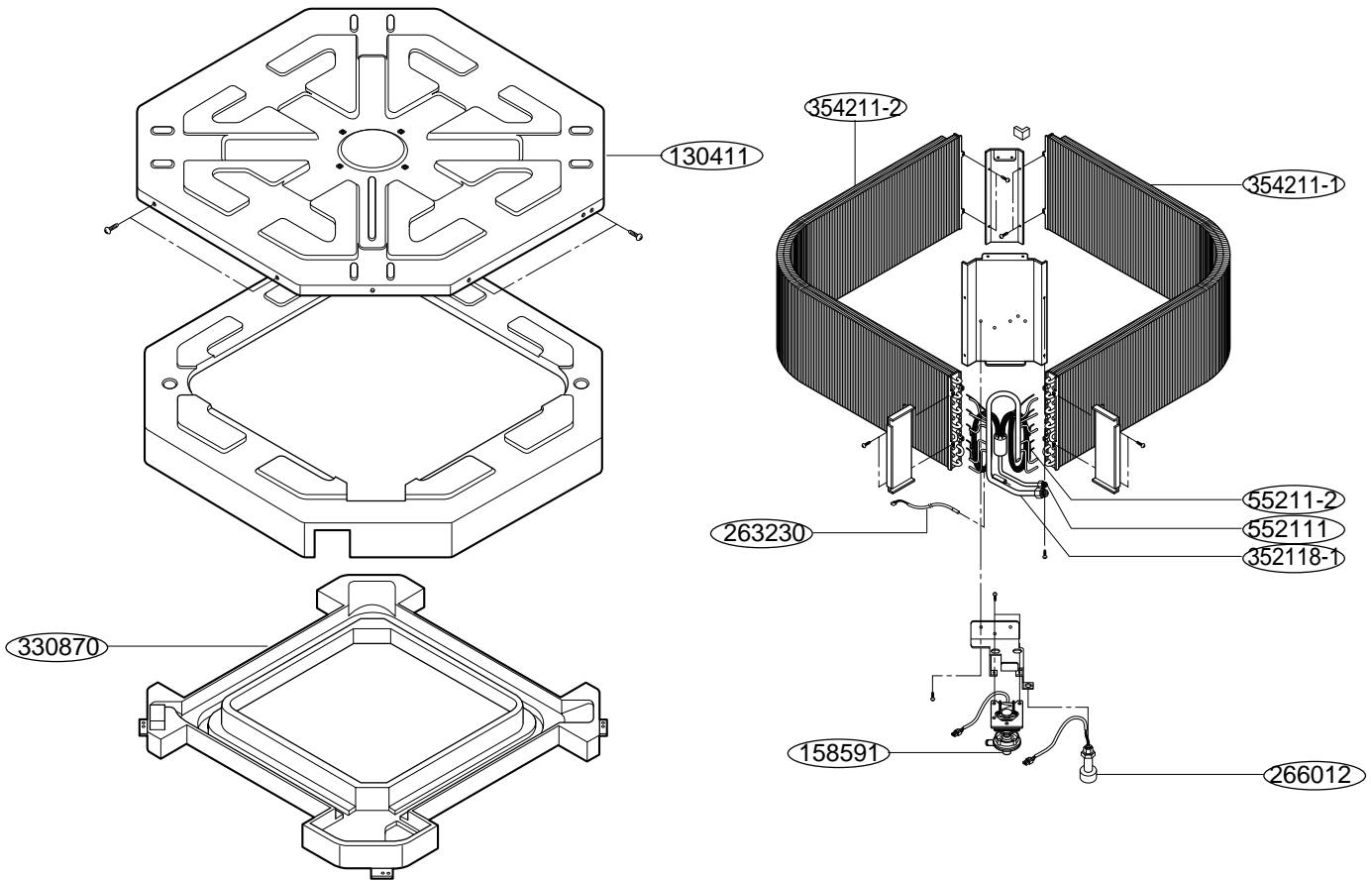
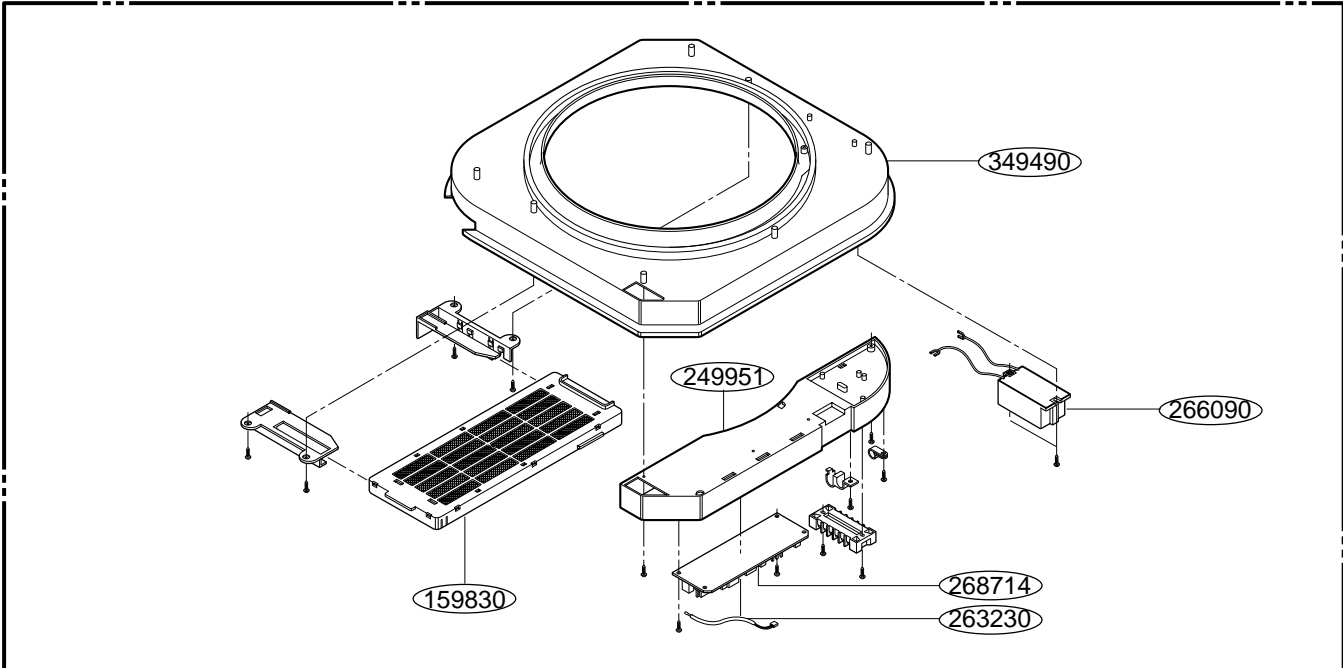

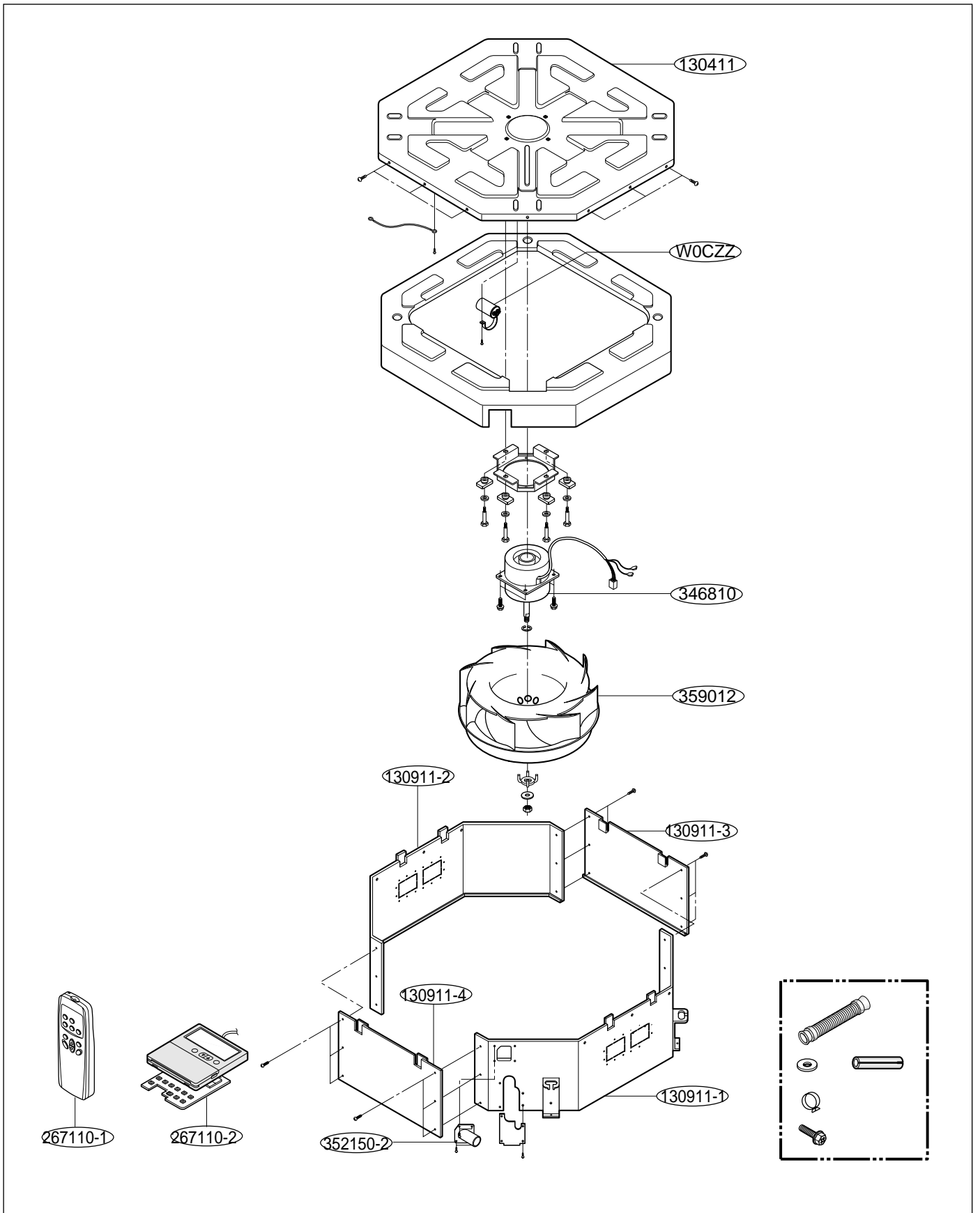

## Parts List

LOCATION No.	DESCRIPTION	Part No.			REMARKS
		ATNC368DLCA	ATNH368DLCA	ATNC488DLCA	
130411	BASE ASSEMBLY,WELD[INDOOR]	3041A10016A	3041A10016A	3041A10016A	R
130911-1	CABINET ASSEMBLY,INDOOR	3091A10030A	3091A10030A	3091A10030A	R
130911-2	CABINET ASSEMBLY,INDOOR	3091A10030B	3091A10030B	3091A10030B	R
130911-3	CABINET ASSEMBLY,INDOOR	3091A10031A	3091A10031A	3091A10031A	R
130911-4	CABINET ASSEMBLY,INDOOR	3091A10031B	3091A10031B	3091A10031B	R
158591	PUMP ASSEMBLY,WATER	5859A20001D	5859A20001D	5859A20001D	R
266012	SWITCH ASSEMBLY,FLOAT	6601A20001F	6601A20001F	6601A20001F	R
159830	AIR CLEANER ASSEMBLY	5983A10003D	5983A10003D	5983A10003D	R
249951	CONTROL BOX ASSEMBLY,INDOOR	4995A22004B	4995A22004A	6609A20005D	R
349490	CONTROL BOX ASSY	4995A20168A	4995A20168A	4995A22004D	R
263230-1	THERMISTOR ASSEMBLY	6323AQ3226F	6323AQ3226F	4995A20168A	R
263230-2	THERMISTOR ASSEMBLY	6323AQ3226F	6323AQ3226F	4995A20168A	R
266090	H.V ASSEMBLY	6609A20005D	6609A20005D	6323AQ3226F	R
267110-1	REMOTE CONTROLLER ASSEMBLY	6711A20039J	6711A20039K	6711A20039J	R
267110-2	REMOTE CONTROLLER ASSEMBLY	6711A20076K	6711A20076J	6711A20076K	R
330870	DRAIN PAN ASSEMBLY	3087A10006A	3087A10006A	3087A10006A	R
346810	MOTOR ASSEMBLY,INDOOR	4681A20006J	4681A20006J	4681A20006H	R
354211-1	EVAPORATOR ASSEMBLY,BENDING	5421A10016B	5421A10016B	5421A10016B	R
354211-2	EVAPORATOR ASSEMBLY,BENDING	5421A10016A	5421A10016A	5421A10016A	R
552111	TUBE ASSEMBLY,CAPILLARY	5211A20316E	5211A20316E	5211A20316A	R
352118-1	TUBE ASSEMBLY,MENIFOLD(INDOOR)	5211A20251C	5211A20251C	5211A20251A	R
352118-2	TUBE ASSEMBLY,MENIFOLD(INDOOR)	5211A20251B	5211A20251B	5211A20251B	R
359012	FAN ASSEMBLY,TURBO	5900A10003B	5900A10003B	5900A10003B	R
W0CZZ	CAPACITOR,DRAWING	3H00660M	3H00660M	2A00986D	R

## Parts List

LOCATION No.	DESCRIPTION	Part No.			REMARKS
		ATNH488DLCA	ATNC608DLCA	ATNH608DLCA	
130411	BASE ASSEMBLY,WELD[INDOOR]	3041A10016A	3041A10016A	3041A10016A	R
130911-1	CABINET ASSEMBLY,INDOOR	3091A10030A	3091A10030A	3091A10030A	R
130911-2	CABINET ASSEMBLY,INDOOR	3091A10030B	3091A10030B	3091A10030B	R
130911-3	CABINET ASSEMBLY,INDOOR	3091A10031A	3091A10031A	3091A10031A	R
130911-4	CABINET ASSEMBLY,INDOOR	3091A10031B	3091A10031B	3091A10031B	R
158591	PUMP ASSEMBLY,WATER	5859A20001D	5859A20001D	5859A20001D	R
266012	SWITCH ASSEMBLY,FLOAT	6601A20001F	6601A20001F	6601A20001F	R
159830	AIR CLEANER ASSEMBLY	5983A10003D	5983A10003D	5983A10003D	R
249951	CONTROL BOX ASSEMBLY,INDOOR	6609A20005D	6609A20005D	6609A20005D	R
349490	CONTROL BOX ASSY	4995A22004C	4995A22004F	4995A22004E	R
263230-1	THERMISTOR ASSEMBLY	4995A20168A	4995A20168A	4995A20168A	R
263230-2	THERMISTOR ASSEMBLY	4995A20168A	4995A20168A	4995A20168A	R
266090	H.V ASSEMBLY	6323AQ3226F	6323AQ3226F	6323AQ3226F	R
267110-1	REMOTE CONTROLLER ASSEMBLY	6711A20039K	6711A20039J	6711A20039K	R
267110-2	REMOTE CONTROLLER ASSEMBLY	6711A20076J	6711A20076K	6711A20076J	R
330870	DRAIN PAN ASSEMBLY	3087A10006A	3087A10006A	3087A10006A	R
346810	MOTOR ASSEMBLY,INDOOR	4681A20006H	4681A20006M	4681A20006M	R
354211-1	EVAPORATOR ASSEMBLY,BENDING	5421A10016B	5421A10016B	5421A10016B	R
354211-2	EVAPORATOR ASSEMBLY,BENDING	5421A10016A	5421A10016A	5421A10016A	R
552111	TUBE ASSEMBLY,CAPILLARY	5211A20316A	5211A20316B	5211A20316B	R
352118-1	TUBE ASSEMBLY,MENIFOLD(INDOOR)	5211A20251A	5211A20251A	5211A20251A	R
352118-2	TUBE ASSEMBLY,MENIFOLD(INDOOR)	5211A20251B	5211A20251B	5211A20251B	R
359012	FAN ASSEMBLY,TURBO	5900A10003B	5900A10003B	5900A10003B	R
W0CZZ	CAPACITOR,DRAWING	2A00986D	2A00986D	2A00986D	R

Ceiling Concealed Duct Type

ATNC-HL, ABNC-GL,  
ATNH-HL, ABNH-GL

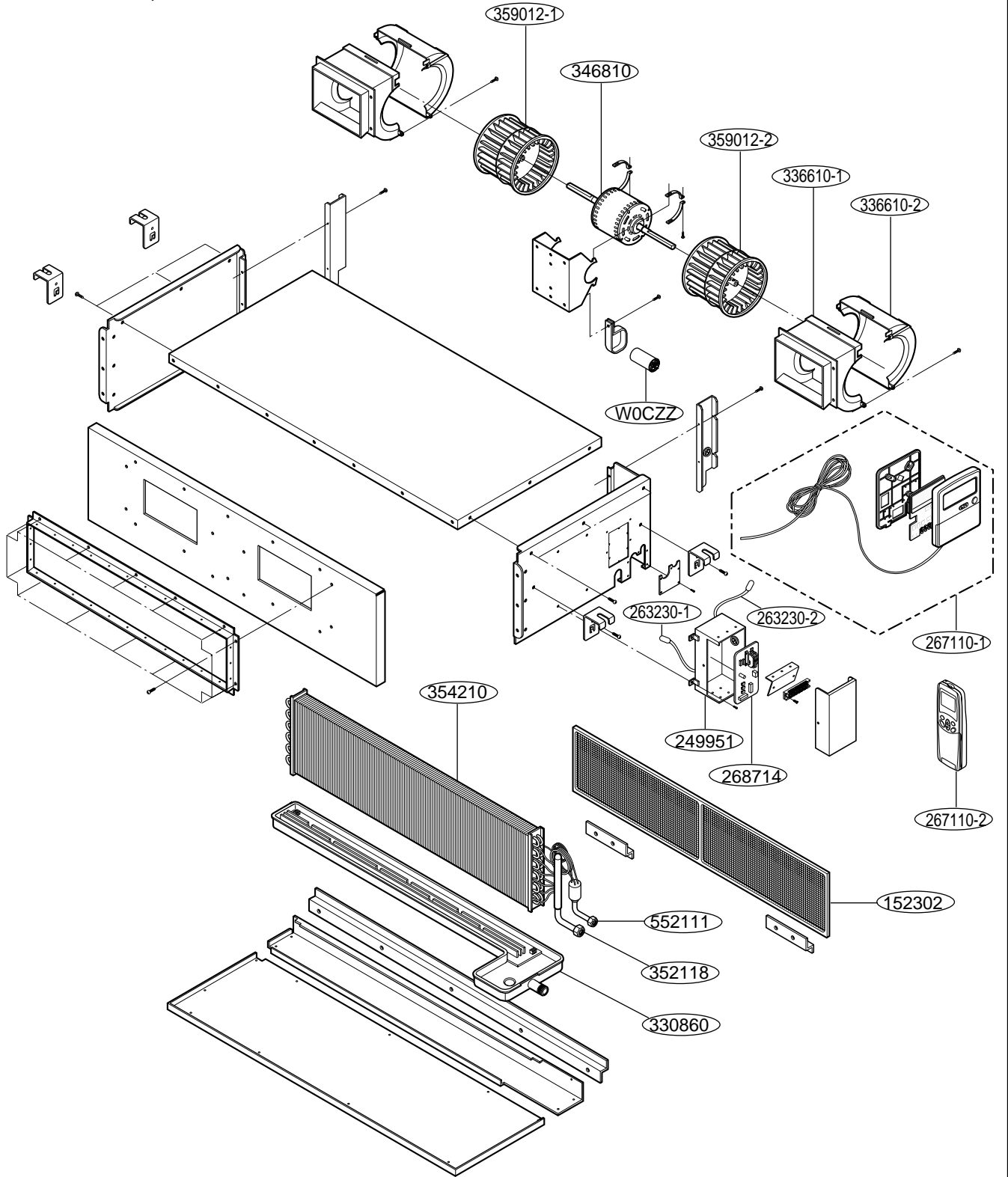



## Parts List

LOCATION No.	DESCRIPTION	Part No.				REMARKS
		ABNC186BLAA	ABNH186BLAA	ABNC246HLAA	ABNH246HLAA	
336610-1	HOUSING (MECH)	3660A20017A	3660A20017A	3660A20017A	3660A20017A	R
336610-2	HOUSING (MECH)	3660A20018A	3660A20018A	3660A20018A	3660A20018A	R
346810	MOTOR ASSEMBLY,INDOOR	4681A10013C	4681A10013C	4681A10013C	4681A10013C	R
359012-1	FAN ASSEMBLY,BLOWER	5901A10028B	5901A10028B	5901A10028B	5901A10028B	R
359012-2	FAN ASSEMBLY,BLOWER	5901A10026A	5901A10026A	5901A10026A	5901A10026A	R
W0CZZ	CAPACITOR,DRAWING	2A00986D	2A00986D	2A00986D	2A00986D	R
354210	EVAPORATOR ASSEMBLY	5421A20100A	5421A20100A	5421A20100B	5421A20100B	R
352118	TUBE ASSEMBLY,MENIFOLD	5211A20465B	5211A20465B	5211A20465B	5211A20465B	R
552111	TUBE ASSEMBLY,CAPI	5211A20466J	5211A20466J	5211A20466H	5211A20466H	R
33860	DRAIN PAN ASSEMBLY	3087A10008B	3087A10008B	3087A10008B	3087A10008B	R
249951	CONTROL BOX ASSEMBLY	4995A10081A	4995A20164N	4995A10081B	4995A20164Q	R
268714	PWB(PCB) ASSEMBLY	6871A10071P	6871A10071G	6871A10071Q	6871A10071H	R
263230-1	THERMISTOR ASSY	6323AQ3226G	6323AQ3226G	6323AQ3226G	6323AQ3226G	R
263230-2	THERMISTOR ASSEMBL	6323AQ3214E	6323AQ3214E	6323AQ3214E	6323AQ3214E	R
267110-1	REMOTE CONTROLLER	6711A20043E	6711A20043D	6711A20043E	6711A20043D	R
267110-2	REMOTE CONTROLLER	6711A20041D	6711A20041E	6711A20041D	6711A20041E	R
152302	FILTER(MECH),A/C	5230A30001M	5230A30001M	5230A30001M	5230A30001M	R

## Parts List

LOCATION No.	DESCRIPTION	Part No.				REMARKS
		ABNC306GLAA	ABNH306GLAA	ABNC368GLAA	ABNH368GLAA	
336610-1	HOUSING (MECH),WRAPPER	3660A20019A	3660A20019A	3660A20019A	3660A20019A	R
336610-2	HOUSING (MECH),WRAPPER	3660A20020A	3660A20020A	3660A20020A	3660A20020A	R
346810	MOTOR ASSEMBLY,INDOOR	4681A10013J	4681A10013J	4681A10013A	4681A10013A	R
359012-1	FAN ASSEMBLY,BLOWER	5901A10026A	5901A10026A	5901A10026A	5901A10026A	R
359012-2	FAN ASSEMBLY,BLOWER	5901A10028J	5901A10028J	5901A10028A	5901A10028A	R
W0CZZ	CAPACITOR,DRAWING	2A00986D	2A00986D	2A00986D	2A00986D	R
354210	EVAPORATOR ASSEMBLY,FIRST	5421A100247A	5421A10027A	5421A10027A	5421A10027A	R
552111	TUBE ASSEMBLY,CAPILLARY	5211A20450G	5211A20450G	5211A20450H	5211A20450H	R
352118	TUBE ASSEMBLY,MENIFOLD(INDOOR)	5211A20416A	5211A20416A	5211A20416A	5211A20416A	R
330860	DRAIN PAN ASSEMBLY	3087A10008A	3087A10008A	3087A10008A	3087A10008A	R
249951	CONTROL BOX ASSEMBLY,INDOOR	4995A22003B	4995A22003A	4995A20164B	4995A20011W	R
268714	PWB(PCB) ASSEMBLY,MAIN	6871A20181J	6871A20181H	6871A20181B	6871A20181A	R
263230-1	THERMISTOR ASSY	6323AQ3226G	6323AQ3226G	6323AQ3226G	6323AQ3226G	R
263230-2	THERMISTOR ASSEMBLY	6323AQ3214E	6323AQ3214E	6323AQ3214E	6323AQ3214E	R
267110-1	REMOTE CONTROLLER ASSEMBLY	6711A20043E	6711A20043D	6711A20043E	6711A20043D	R
267110-2	REMOTE CONTROLLER ASSEMBLY	6711A20041D	6711A20041E	6711A20041D	6711A20041E	R
152302	FILTER(MECH),A/C	5230A30001L	5230A30001L	5230A30001L	5230A30001L	R

Ceiling Concealed Duct Type

ABNC-EL, ABNH-EL

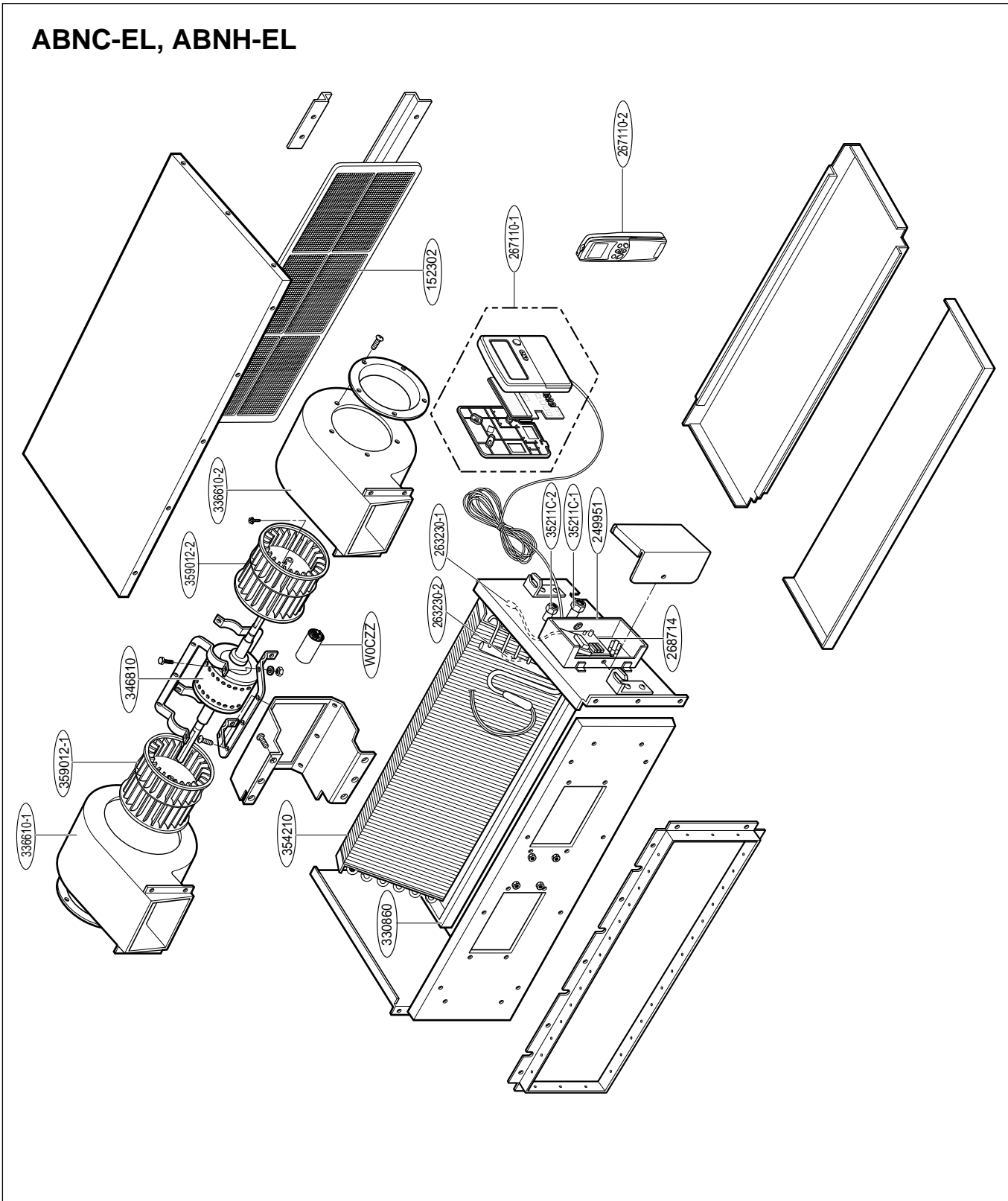

## Parts List

LOCATION No.	DESCRIPTION	Part No.				REMARKS
		ABNC488ELAA	ABNH488ELAA	ABNC608ELAA	ABNH608ELAA	
336610-1	HOUSING (MECH),WRAPPER	3661A10009E	3661A10009E	3661A10009E	3661A10009E	R
336610-2	HOUSING (MECH),WRAPPER	3661A10009F	3661A10009F	3661A10009F	3661A10009F	R
346810	MOTOR ASSEMBLY,INDOOR	4681A20005K	4681A20005K	4681A20005Q	4681A20005Q	R
359012-1	FAN ASSEMBLY,BLOWER	5901A10015E	5901A10015E	5901A10015E	5901A10015E	R
359012-2	FAN ASSEMBLY,BLOWER	5901A10015F	5901A10015F	5901A10015F	5901A10015F	R
W0CZZ	CAPACITOR,DRAWING	0CZZA20001C	0CZZA20001C	0CZZA20001B	0CZZA20001B	R
354210	EVAPORATOR ASSEMBLY,FIRST	5421A20008A	5421A20008A	5421A20008E	5421A20008E	R
35211C-1	TUBE ASSY,DISCHARGE (INDOOR)	5211A30077A	5211A30077A	5211A30077A	5211A30077A	R
35211C-2	TUBE ASSY,DISCHARGE (INDOOR)	5211A30094B	5211A30094B	5211A30077B	5211A30077B	R
330860	DRAIN PAN ASSEMBLY	3086A30001H	3086A30001H	3086A30001H	3086A30001H	R
249951	CONTROL BOX ASSEMBLY,INDOOR	4995A20164K	4995A20164J	4995A20164K	4995A20164J	R
268714	PWB(PCB) ASSEMBLY,MAIN	6871A10040M	6871A10040M	6871A10040N	6871A10040N	R
263230-1	THERMISTOR ASSY	6323AQ3226G	6323AQ3226G	6323AQ3226G	6323AQ3226G	R
263230-2	THERMISTOR ASSEMBLY	6323AQ3214Q	6323AQ3214Q	6323AQ3214Q	6323AQ3214Q	R
267110-1	REMOTE CONTROLLER ASSEMBLY	6711A20043E	6711A20043D	6711A20043E	6711A20043D	R
267110-2	REMOTE CONTROLLER ASSEMBLY	6711A20041D	6711A20041E	6711A20041D	6711A20041E	R
152302	FILTER(MECH),A/C	5230A30001A	5230A30001A	5230A30001A	5230A30001A	R



## Parts List

LOCATION No.	DESCRIPTION	Part No.			REMARKS
		AVNC186BLAA	AVNH186BLAA	AVNC246BLAA	
135314	GRILLE ASSEMBLY,INLET SUB	5237AP2817B	5237AP2817B	5237AP2817B	R
137213	PANEL ASSEMBLY,FRONT(INDOOR)	3720AP2767P	3720AP2767P	3720AP2767P	R
146811	MOTOR ASSEMBLY,STEP	4681AR2727G	4681AR2727G	4681AR2727G	R
152302	FILTER(MECH),A/C	5230AP7093A	5230AP7093A	5230AP7093A	R
159911-1	VANE ASSY,HORIZONTAL	5991AP2867B	5991AP2867B	5991AP2867B	R
159911-2	VANE ASSY	5991AP7334C	5991AP7334C	5991AP7334C	R
166000-1	SWITCH,PUSH	6600AP2059B	6600AP2059B	6600AP2059B	R
166000-2	SWITCH,PUSH	6600AP2059B	6600AP2059B	6600AP2059B	R
235450	DISPLAY ASSY (MECH)	3545AP7224A	3545AP7224A	3545AP7224A	R
237900	WINDOW,DISPLAY	3790AP7080A	3790AP7080A	3790AP7080A	R
261704	TRANSFORMER,POWER	6171AQ3198E	6171AQ3198E	6171AQ3198E	R
263230	THERMISTOR ASSEMBLY	6323AQ2333Y	6323AQ2333Y	6323AQ2333Y	R
267110	REMOTE CONTROLLER ASSEMBLY	6711A20010J	6711A20010K	6711A20010J	R
268712	PWB(PCB) ASSY,DISPLAY	6871AQ3263A	6871AQ3263A	6871AQ3263A	R
268714	PWB(PCB) ASSY,MAIN	6871A20042L	6871A20042H	6871A20042L	R
330870	DRAIN PAN ASSEMBLY	3087AP7233A	3087AP7233A	3087AP7233A	R
342800	BEARING	3H02821B	3H02821B	3H02821B	R
346810	MOTOR ASSEMBLY,INDOOR	4681AP2306G	4681AP2306G	4681AP2306E	R
352115	TUBE ASSEMBLY,EVAPORATOR IN	5211A20253C	5211A20253C	5211A20253B	R
35211A	TUBE ASSEMBLY,SUCTION INDOOR	5211AP2813D	5211AP2813D	5211AP2813A	R
354210	EVAPORATOR ASSEMBLY,FIRST	5421AP2812B	5421AP2812B	5421AP2812A	R
359010	FAN ASSY,CROSS FLOW	5901AR2351E	5901AR2351E	5901AR2351E	R
352150	HOSE ASSY, DRAIN	5251AP2460B	5251AP2460B	5251AP2460B	R
W0CZZ	CAPACITOR,DRAWING	3H00671A	3H00671A	3H00671A	R
130911	CABINET ASSY(INDOOR)	3091AP2533A	3091AP2532A	3091A2533A	R

## Parts List

LOCATION No.	DESCRIPTION	Part No.			REMARKS
		AVNH246BLAA	AVNC3066BLAA	AVNH306BLAA	
135314	GRILLE ASSEMBLY,INLET SUB	5237AP2817B	5237AP2817B	5237AP2817B	R
137213	PANEL ASSEMBLY,FRONT(INDOOR)	3720AP2767P	3720AP2767P	3720AP2767P	R
146811	MOTOR ASSEMBLY,STEP	4681AR2727G	4681AR2727G	4681AR2727G	R
152302	FILTER(MECH),A/C	5230AP7093A	5230AP7093A	5230AP7093A	R
159911-1	VANE ASSY,HORIZONTAL	5991AP2867B	5991AP2867B	5991AP2867B	R
159911-2	VANE ASSY	5991AP7334C	5991AP7334C	5991AP7334C	R
166000-1	SWITCH,PUSH	6600AP2059B	6600AP2059B	6600AP2059B	R
166000-2	SWITCH,PUSH	6600AP2059B	6600AP2059B	6600AP2059B	R
235450	DISPLAY ASSY (MECH)	3545AP7224A	3545AP7224A	3545AP7224A	R
237900	WINDOW,DISPLAY	3790AP7080A	3790AP7080A	3790AP7080A	R
261704	TRANSFORMER,POWER	6171AQ3198E	6171AQ3198E	6171AQ3198E	R
263230	THERMISTOR ASSEMBLY	6323AQ2333Y	6323AQ2333Y	6323AQ2333Y	R
267110	REMOTE CONTROLLER ASSEMBLY	6711A20010K	6711A20010J	6711A20010K	R
268712	PWB(PCB) ASSY,DISPLAY	6871AQ3263A	6871AQ3263A	6871AQ3263A	R
268714	PWB(PCB) ASSY,MAIN	6871A20042H	6871A20042L	6871A20042H	R
330870	DRAIN PAN ASSEMBLY	3087AP7233A	3087AP7233A	3087AP7233A	R
342800	BEARING	3H02821B	3H02821B	3H02821B	R
346810	MOTOR ASSEMBLY,INDOOR	4681AP2306E	4681AP2306L	4681AP2306L	R
352115	TUBE ASSEMBLY,EVAPORATOR IN	5211A20253B	5211A20253B	5211A20253B	R
35211A	TUBE ASSEMBLY,SUCTION INDOOR	5211AP2813A	5211AP2813A	5211AP2813A	R
354210	EVAPORATOR ASSEMBLY,FIRST	5421AP2812A	5421AP2812A	5421AP2812A	R
359010	FAN ASSY,CROSS FLOW	5901AR2351E	5901AR2351E	5901AR2351E	R
352150	HOSE ASSY, DRAIN	5251AP2460B	5251AP2460B	5251AP2460B	R
W0CZZ	CAPACITOR,DRAWING	3H00671A	3H00671A	3H00671A	R
130911	CABINET ASSY(INDOOR ASSY0	3019AP2533A	3019AP2533A	3019AP2533A	R

Model No.: AUUC186A/AB

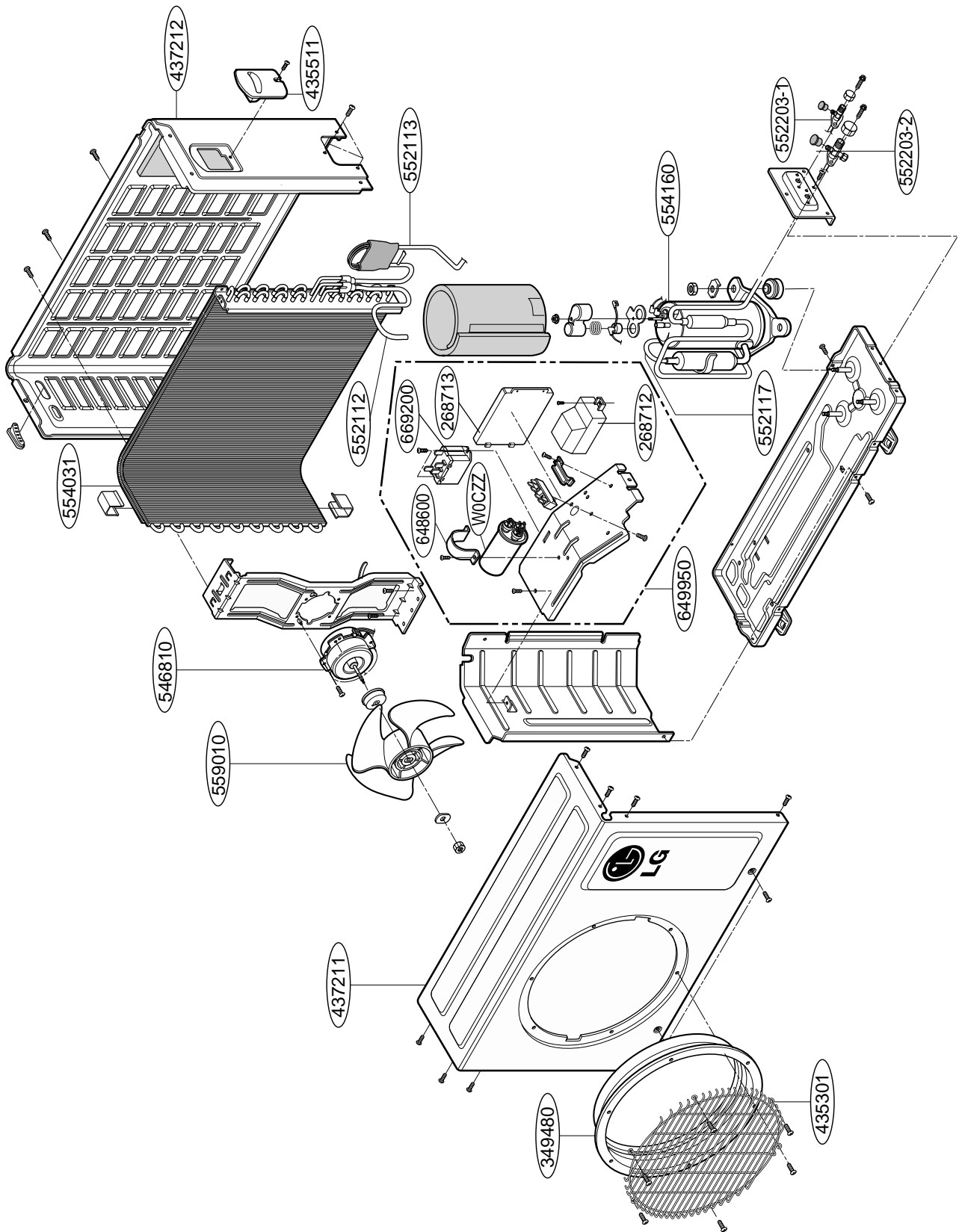



Model No.: AUUH186A/AB, AUUC246A/AB

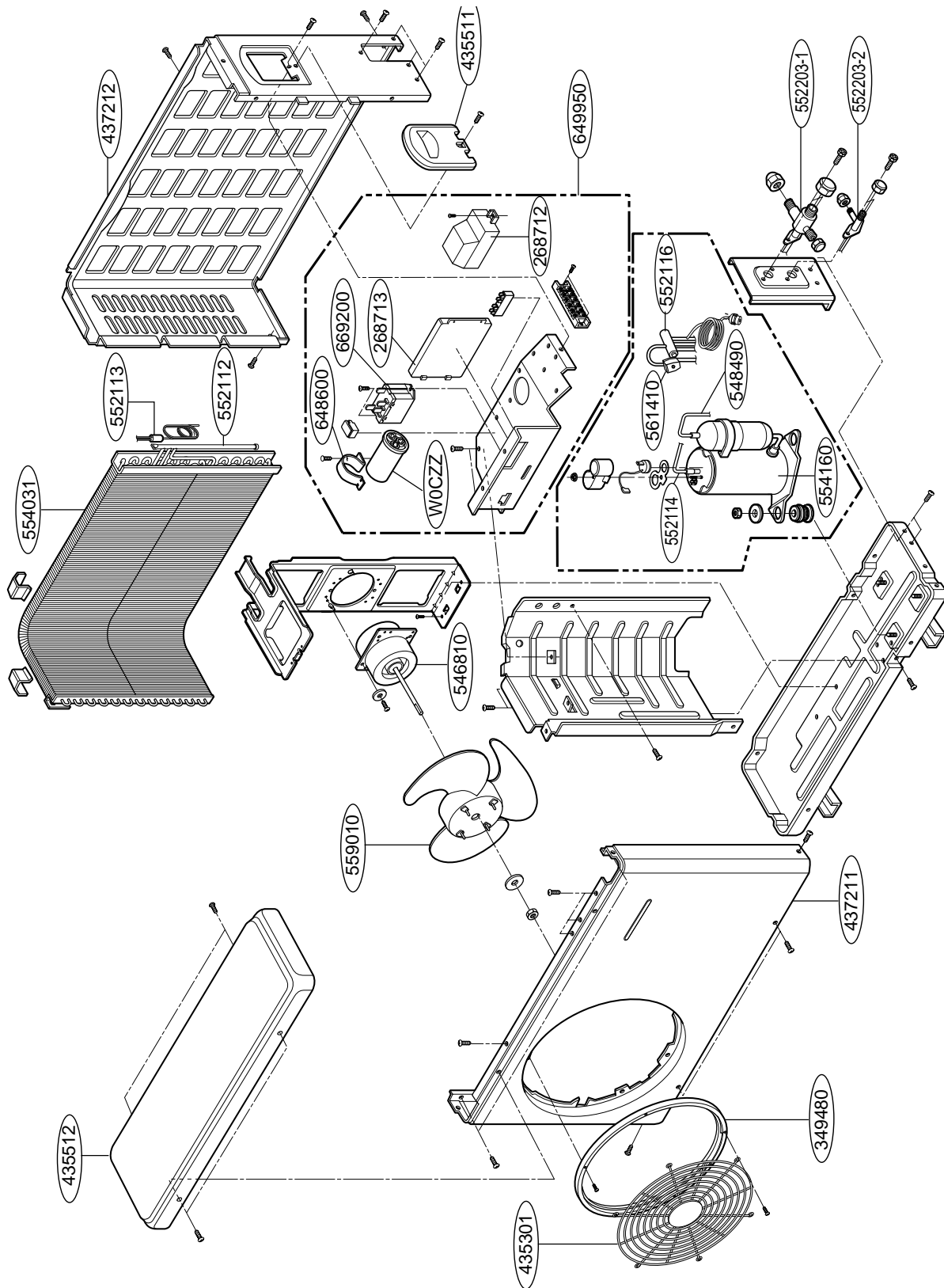

## 2. OUTDOOR UNITS

Model No.: AUUH246A/AB, AUUC306A/AB, AUUH306A/AB

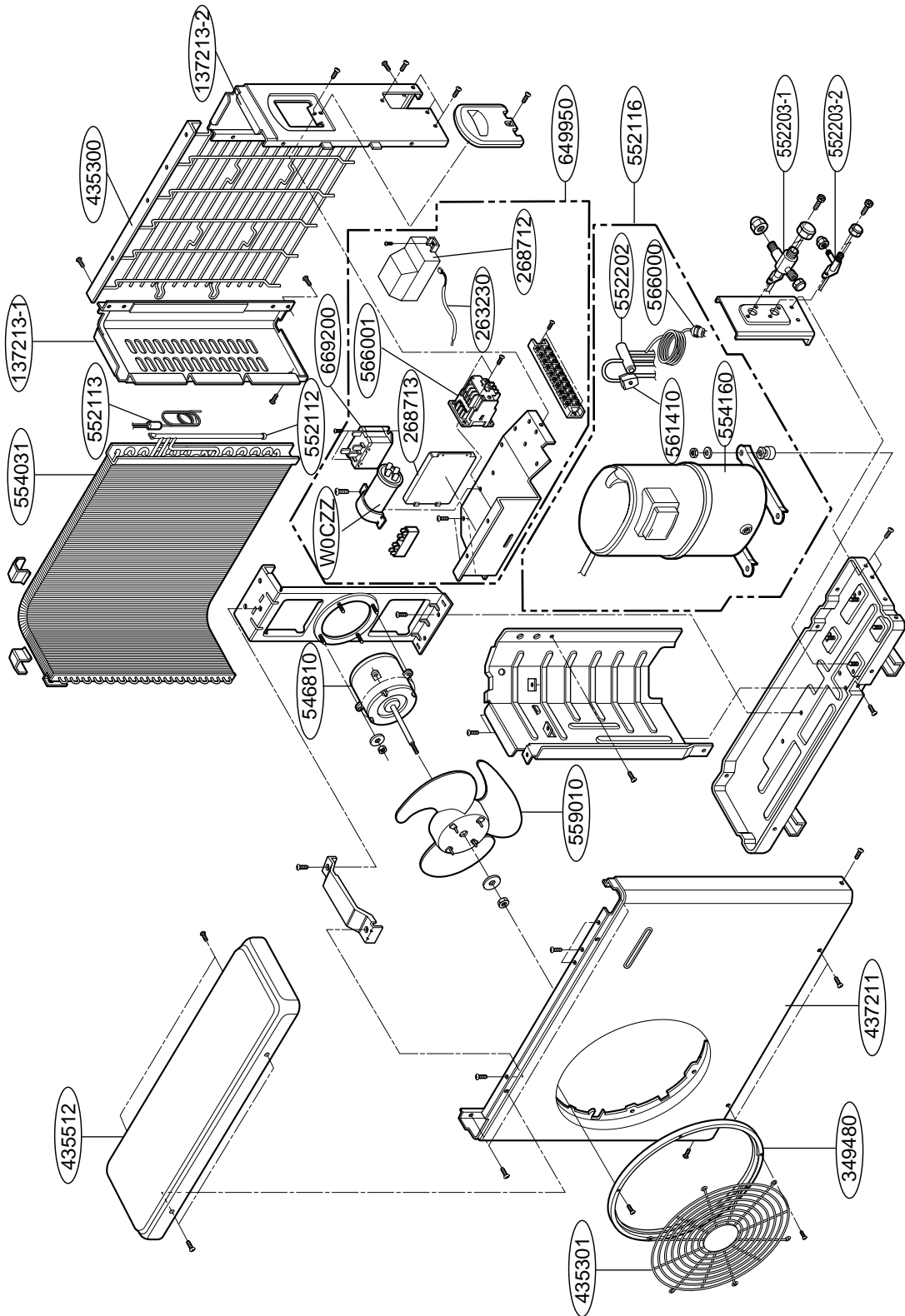

## Parts List

LOCATION No.	DESCRIPTION	Part No.				REMARKS
		AUUC186A	AUUC186AB	AUUH186A	AUUH186AB	
349480	ORIFICE	4948A20005A	4948A20005A	4948A20005A	4948A20005A	R
433501	GRILLE,DISCHARGE	3530A20007B	3530A20007B	3530A20007B	3530A20007B	R
437211	PANEL ASSY,FRONT	3721A20113A	3721A20113A	3721A20005Q	3721A20005Q	R
437212	PANEL ASSY,REAR	3721A20114A	3721A20114A	3720AP0003L	3720AP0003L	R
546810	MOTOR ASSEMBLY,OUTDOOR	4681A20028P	4681A20028P	4681A20028P	4681A20028P	R
552112	TUBE ASSEMBLY,CONDENSER IN	5211A20765M	5211A20765M	5211A30298V	5211A30298V	R
552113	TUBE ASSEMBLY,CONDENSER OUT	5211A32003A	5211A32003A	5211A24003A	5211A24003A	R
552116	TUBE ASSEMBLY,REVERSING	-	-	5211A24005A	5211A24005A	R
561410	COIL ASSEMBLY,REVERSING VALVE	-	-	6141AR3733R	6141AR3733R	R
552117	TUBE ASSEMBLY,SUCTION	5211A33008A	5211A33008A	-	-	R
552203-1	VALVE,SERVICE	5220A20013A	5220A20013A	5220A20013A	5220A20013A	R
552203-2	VALVE,SERVICE	5220A20007A	5220A20007A	5220A20007A	5220A20007A	R
554031	CONDENSER ASSEMBLY,BENT	5403A20104C	5403A20104C	5403A20022R	5403A20022R	R
554160	COMPRESSOR ASSEMBLY	5416A90023A	5416A90023A	5416A90023A	5416A90023A	R
559010	FAN ASSEMBLY,PROPELLER	5901A10032A	5901A10032A	5901A10032A	5901A10032A	R
435511	COVER CONTROL	3551A30079A	3551A30079A	3551A30061G	3551A30061G	R
649950	CONTROL BOX ASSEMBLY,OUTDOOR	4995A20319G	4995A20319K	4995A10040U	4995A10040Y	R
268713	PWB(PCB) ASSY,SUB	-	6871A20130K	-	6871A20130K	R
669200	RELAY	6920AP3400A	6920AP3400A	6920AP3400A	6920AP3400A	R
648600	CLAMP CORD	4H02958A	4H02958A	4H02958A	4H02958A	R
W0CZZ	CAPACITOR,DRAWING	2A00986E	2A00986E	2A00986D	2A00986D	R
W0CZZ	CAPACITOR,DRAWING	-	-	2A00986X	2A00986X	R
268712	PWB(PCB) ASSY, DEICER	-	-	6871A20034A	6871A20034A	R

## Parts List

LOCATION No.	DESCRIPTION	Part No.				REMARKS
		AUUC246A	AUUC246AB	AUUH246A	AUUH246AB	
137213-1	PANEL ASSEMBLY,SIDE	-	-	1A00202F	1A00202F	R
137213-2	PANEL ASSEMBLY,SIDE	-	-	3A02284Y	3A02284Y	R
437211	PANEL ASSY,FRONT	1A00196M	1A00196M	1A00197C	1A00197C	R
437212	PANEL ASSY,REAR	3720AP0003L	3720AP0003L	-	-	R
435512	COVER TOP	2A00915H	2A00915H	2A00915G	2A00915G	R
349480	ORIFICE	4948A20005A	4948A20005A	4948AP2527A	4948AP2527A	R
435301	GRILLE,DISCHARGE	-	-	3530A20007J	3530A20007J	R
435300	GRILLE,REAR	-	-	1A00208D	1A00208D	R
546810	MOTOR ASSEMBLY,OUTDOOR	4681A20028P	4681A20028P	4681A20028P	4681A20028P	R
552112	TUBE ASSEMBLY,CONDENSER IN	-	-	5211A30298K	5211A30298K	R
552113	TUBE ASSEMBLY,CONDENSER OUT	5211A21128A	5211A21128A	5211A21133A	5211A21133A	R
552116	TUBE ASSEMBLY,REVERSING	-	-	5211A11001A	5211A11001A	R
548490	ACCUMULATOR ASSEMBLY(MECH)	4849A20036B	4849A20036B	-	-	R
552114	TUBE ASSEMBLY,DISCHARGE (OUTDOOR)	5211A21130A	5211A21130A	-	-	R
552202	VALVE,REVERSING	-	-	5220AR3228E	5220AR3228E	R
552203	VALVE,SERVICE	5220A20007A	5220A20007A	5220A20007A	5220A20007A	R
552203	VALVE,SERVICE	5220A20013A	5220A20013A	5220A20013A	5220A20013A	R
554031	CONDENSER ASSEMBLY,BENT	5403A20058D	5403A20058D	5403A10030A	5403A10030A	R
554160	COMPRESSOR ASSEMBLY	2520UXDP2BA	2520UXDP2BA	5417A10006C	5417A10007C	R
559010	FAN ASSEMBLY,PROPELLER	5901A10032A	5901A10032A	5901A10032A	5901A10032A	R
561410	COIL ASSEMBLY,REVERSING VALVE	-	-	6141AR3733R	6141AR3733R	R
649950	CONTROL BOX ASSEMBLY,OUTDOOR	4995A20319E	4995A20319H	4995A10040Q	4995A10040X	R
268713	PWB(PCB) ASSY,SUB	-	6871A20130K	-	6871A20130K	R
263230	THERMISTOR ASSEMBLY	-	-	3Q35015H	3Q35015H	R
268711	PWB(PCB) ASSY,DEICER	-	-	6871A20034A	6871A20034A	R
669200	RELAY	6920AP3400A	6920AP3400A	6920AP3400A	6920AP3400A	R
W0CZZ	CAPACITOR,DRAWING	2A00986Y	2A00986Y	2A00986D	2A00986D	R
W0CZZ	CAPACITOR,DRAWING	-	-	2A00986X	2A00986X	R

## Parts List

LOCATION No.	DESCRIPTION	Part No.				REMARKS
		AUUC306A	AUUC306AB	AUUH306A	AUUH306AB	
137213-1	PANEL ASSEMBLY,SIDE	1A00202F	1A00202F	1A00202F	1A00202F	R
137213-2	PANEL ASSEMBLY,SIDE	3A02284Y	3A02284Y	3A02284Y	3A02284Y	R
349480	ORIFICE	4948AP2527A	4948AP2527A	4948AP2527A	4948AP2527A	R
435301	GRILLE,DISCHARGE	3530A20007J	3530A20007J	3530A20007J	3530A20007J	R
435511	COVER CONTROL	3551A30071Q	3551A30061G	3551A30071K	3551A30061G	R
546810	MOTOR ASSEMBLY,OUTDOOR	4681A20028P	4681A20028P	4681A20028P	4681A20028P	R
552112	TUBE ASSEMBLY,CONDENSER IN	5211A30298K	5211A30298K	5211A30298K	5211A30298K	R
552113	TUBE ASSEMBLY,CONDENSER OUT	5211A21133C	5211A21133C	5211A21133B	5211A21133B	R
552116	TUBE ASSEMBLY,REVERSING	-	-	5211A11001B	5211A11001B	R
548490	ACCUMULATOR ASSEMBLY(MECH)	4849A22001C	4849A22001C	4849A22001B	4849A22001B	R
552570	MUFFLER ASSY	5257A22002C	5257A22002C	5257A22002B	5257A22002B	R
552202	VALVE,REVERSING	-	-	5220AR3228L	5220AR3228L	R
552203-1	VALVE,SERVICE	5220A20013A	5220A20013A	5220A20013A	5220A20013A	R
552203-2	VALVE,SERVICE	5220A20007A	5220A20007A	5220A20007A	5220A20007A	R
554031	CONDENSER ASSEMBLY,BENT	5403A10030A	5403A10030A	5403A10030A	5403A10030A	R
554160	COMPRESSOR ASSEMBLY	5416A90027A	5416A90027A	5416A90027A	5416A90027A	R
559010	FAN ASSEMBLY,PROPELLER	5901A10032A	5901A10032A	5901A10032A	5901A10032A	R
561410	COIL ASSEMBLY,REVERSING VALVE	-	-	6141AR3733R	6141AR3733R	R
649950	CONTROL BOX ASSEMBLY,OUTDOOR	4995A20319F	4995A20319J	4995A10040Q	4995A10040X	R
263230	THERMISTOR ASSEMBLY	-	-	3Q35015H	3Q35015H	R
268711	PWB(PCB) ASSY,DEICER	-	-	6871A20034A	6871A20034B	R
669200	RELAY	6920AP3400A	6920AP3400A	6920AP3400A	6920AP3400A	R
648600	CLAMP CAPACITOR	4H00442C	4H00442C	4H00442F	4H00442F	R
				4H00930C	4H00930C	
W6640	TERMINAL BLOCK	3A00093A	3A00093A	3A00093A	3A00093A	R
W0CZZ	CAPACITOR,DRAWING	2A00986Y	2A00986Y	2A00986D	2A00986D	R
W0CZZ	CAPACITOR,DRAWING	-	-	2A00986X	2A00986X	R
268713	PWB(PCB) ASSY, SUB	-	6871A20130K	-	6871A20130K	R

Model No.: AUUC368A/AB, AUUH368A/AB

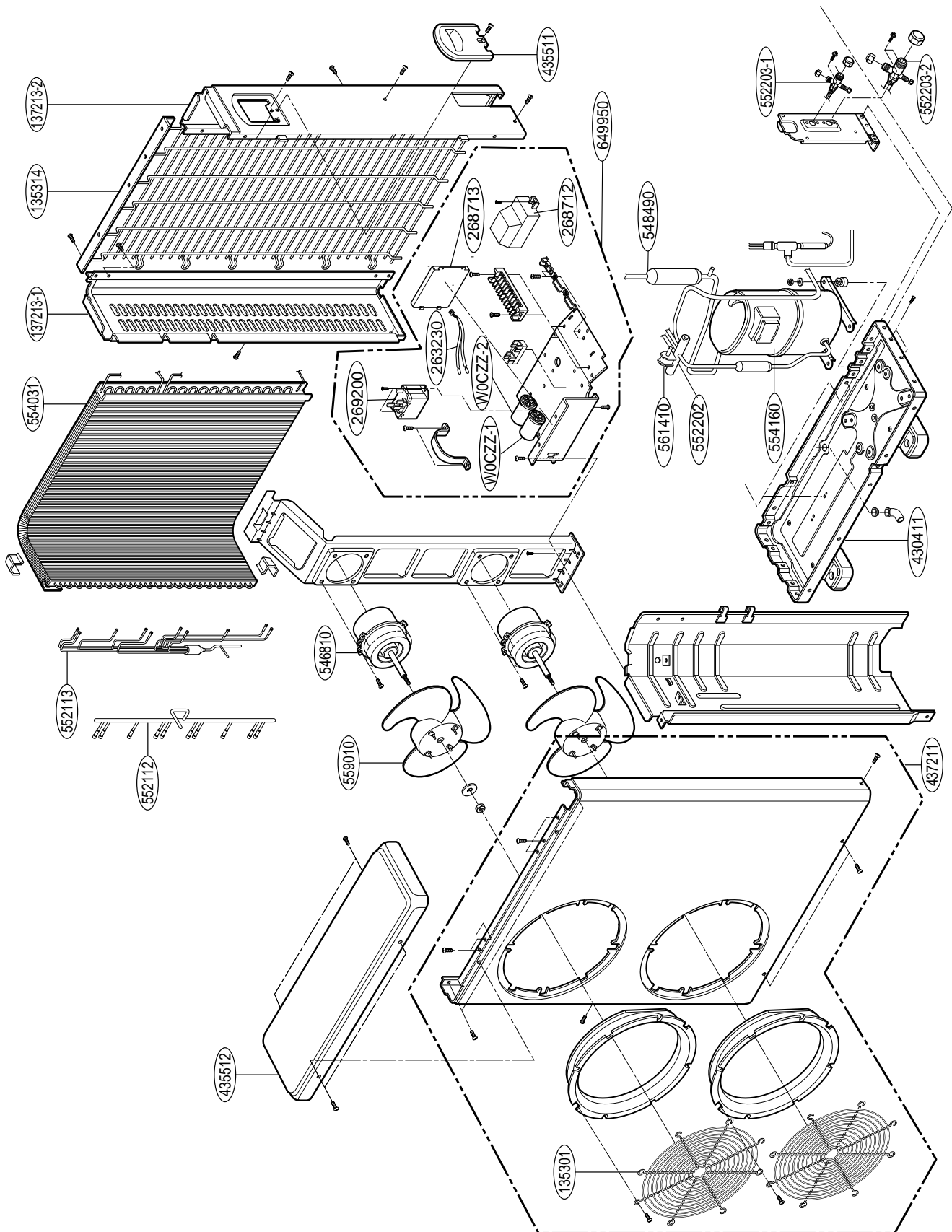

Model No.: AUUC488A/AB, AUUH488A/AB, AUUC608A/AB, AUUH608A/AB

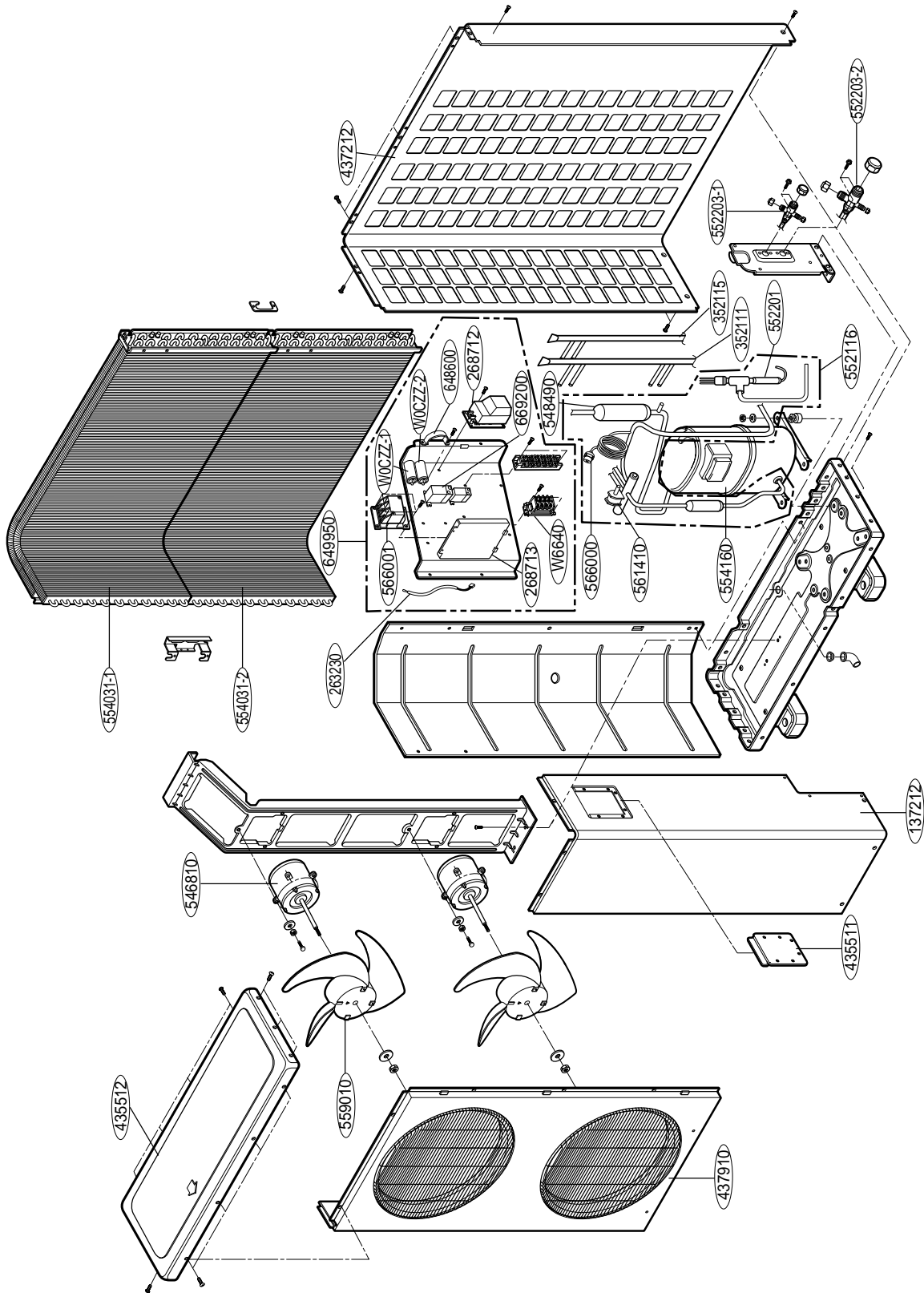

## Parts List

LOCATION No.	DESCRIPTION	Part No.				REMARKS
		AUUC368A	AUUC368AB	AUUH368A	AUUH368AB	
137213-1	PANEL ASSEMBLY,SIDE	3721A10110A	3721A10110A	3721A10110A	3721A10110A	R
137213-2	PANEL ASSEMBLY,SIDE	3721A10111B	3721A10111B	3721A10111B	3721A10111B	R
435512	COVER ASSEMBLY TOP	3H03266H	3H03266H	3H03266H	3H03266H	R
437211	PANEL ASSY,FRONT	3721A10109A	3721A10109A	3721A10109A	3721A10109A	R
135301	GRILLE,DISCHARGE	3530A20006B	3530A20006B	3530A20006B	3530A20006B	R
135314	GRILLE,REAR	3530A10176B	3530A10176B	3530A10176B	3530A10176B	R
546810	MOTOR ASSEMBLY,OUTDOOR	4681AR1392W	4681AR1392W	4681AR1392W	4681AR1392W	R
552112	TUBE ASSEMBLY,CONDENSER IN	5211A11010B	5211A11010B	5211A11010B	5211A11010B	R
552113	TUBE ASSEMBLY,CONDENSER OUT	5211A14004A	5211A14004A	5211A14004A	5211A14004A	R
552116	TUBE ASSEMBLY,REVERSING	5211A24008A	5211A24008A	5211A24008A	5211A24008A	R
552202	VALVE,REVERSING	3A02080E	3A02080E	3A02080E	3A02080E	R
552203-1	VALVE,SERVICE	5220A20013B	5220A20013B	5220A20013B	5220A20013B	R
552203-2	VALVE,SERVICE	5220A20007A	5220A20007A	5220A20007A	5220A20007A	R
554031	CONDENSER ASSEMBLY,BENT	5403A20168B	5403A20168B	5403A20168B	5403A20168B	R
554160	COMPRESSOR ASSEMBLY	2520UUCY2BA	2520UUCY2BA	2520UUCY2BA	2520UUCY2BA	R
559010	FAN ASSEMBLY,PROPELLER	5901A10033A	5901A10033A	5901A10033A	5901A10033A	R
561410	COIL ASSEMBLY,REVERSING VALVE	-	-	6141AR3733R	6141AR3733R	R
435511	COVER ASSEMBLY CONTROL	3551A30088K	3551A30088K	3551A30088K	3551A30088K	R
649950	CONTROL BOX ASSEMBLY,OUTDOOR	4995A20319P	4995A20319N	4995A20319M	4995A20319L	R
263230	THERMISTOR ASSEMBLY	-	-	3Q35015K	3Q35015K	R
268712	PWB(PCB) ASSY,DEICER	-	-	6871A20034A	6871A20034A	R
669200	RELAY	-	-	3A00261C	3A00261C	R
W0CZZ	CAPACITOR,DRAWING	3A02157A	3A02157A	3A02157A	3A02157A	R
268713	PWB(PCB)ASSY, SUB	-	6871A20130K	-	6871A20130K	R



## Parts List

LOCATION No.	DESCRIPTION	Part No.				REMARKS
		AUUC488A	AUUC488AB	AUUH488A	AUUH488AB	
137212	PANEL ASSEMBLY,SIDE	3720AP1215B	3720AP1215B	3720AP1215B	3720AP1215B	R
437212	PANEL ASSEMBLY,REAR	3720AP1202C	3720AP1202C	3720AP1202C	3720AP1202C	R
135301	GRILLE,DISCHARGE	3530AP1225D	3530AP1225D	3530AP1225D	3530AP1225D	R
435512	COVER ASSEMBLY TOP	3550AP1213B	3550AP1213B	3550AP1213B	3550AP1213B	R
435511	COVER ASSEMBLY CONTROL	3A01293X	3A01293X	3A01293X	3A01293X	R
437910	PANEL ASSY,FRONT	3720AP1212B	3720AP1212B	3720AP1212B	3720AP1212B	R
546810	MOTOR ASSEMBLY,OUTDOOR	4681A20008R	4681A20008R	4681A20008R	4681A20008R	R
352111	TUBE ASSEMBLY,CONNECTOR	5211A11022A	5211A11022A	5211A11022A	5211A11022A	R
552115	TUBE ASSEMBLY MENI FOLD	5211A10166G	5211A10166G	5211A10166G	5211A10166G	R
552201	VALVE CHECK	3A01020D	3A01020D	3A01020D	3A01020D	R
552116	TUBE ASSEMBLY,REVERSING	5211A10391G	5211A10391G	5211A10391G	5211A10391G	R
548490	ACCUMULATOR ASSEMBLY	4849A20009H	4849A20009H	4849A20009H	4849A20009H	R
W5210B	TUBE CONNECTOR	5210AP7001R	5210AP7001R	5210AP7001R	5210AP7001R	R
552202	VALVE,REVERSING	3A02080B	3A02080B	3A02080B	3A02080B	R
552203-1	VALVE,SERVICE	5220A20001F	5220A20001F	5220A20001F	5220A20001F	R
552203-2	VALVE,SERVICE	2A00499L	2A00499L	2A00499L	2A00499L	R
554160	COMPRESSOR ASSEMBLY	2520UBAY2BA	2520UBAY2BA	2520UBAY2BA	2520UBAY2BA	R
554031-1	CONDENSER ASSEMBLY,BENT	5403A20193A	5403A20193A	5403A20193A	5403A20193A	R
554031-2	CONDENSER ASSEMBLY,BENT	5403A20193B	5403A20193B	5403A20193B	5403A20193B	R
559010	FAN ASSEMBLY,PROPELLER	1A00195B	1A00195B	1A00195B	1A00195B	R
561410	COIL ASSEMBLY,REVERSING VALVE	-	-	6141AR3733R	6141AR3733R	R
649950	CONTROL BOX ASSEMBLY,OUTDOOR	6615AP2772Z	4995A10010S	4995A30011G	4995A10010J	R
263230	THERMISTOR ASSEMBLY	-	-	3Q35015H	3Q35015H	R
268712	PWB(PCB) ASSY,DEICER	-	-	6871A20034A	6871A20034A	R
566001	SWITCH MAGNET	2A01031K	2A01031K	2A01031K	2A01031K	R
W0CZZ	CAPACITOR,DRAWING	2A00986D	2A00986D	2A00986D	2A00986D	R
268713	PWB(PCB) ASSY,SUB	-	6871A20130K	-	6871A20130K	R

## Parts List

LOCATION No.	DESCRIPTION	Part No.				REMARKS
		AUUC608A	AUUC608AB	AUUH608A	AUUH608AB	
137213	PANEL ASSEMBLY,SIDE	3720AP1215B	3720AP1215B	3720AP1215B	3720AP1215B	R
437212	PANEL ASSEMBLY,REAR	3720AP1202C	3720AP1202C	3720AP1202C	3720AP1202C	R
135301	GRILLE,DISCHARGE	3530AP1225D	3530AP1225D	3530AP1225D	3530AP1225D	R
435512	COVER ASSEMBLY TOP	3550AP1213B	3550AP1213B	3550AP1213B	3550AP1213B	R
437910	PANEL ASSY,FRONT	3720AP1212B	3720AP1212B	3720AP1212B	3720AP1212B	R
546810	MOTOR ASSEMBLY,OUTDOOR	4681A20008R	4681A20008R	4681A20008R	4681A20008R	R
352111	TUBE ASSEMBLY,CONNECTOR	5211A11022B	5211A11022B	5211A11022B	5211A11022B	R
552115	TUBE ASSEMBLY MENI	5211A10166M	5211A10166M	5211A10166M	5211A10166M	R
552201	VALVE CHECK	3A01020D	3A01020D	3A01020D	3A01020D	R
552116	TUBE ASSEMBLY,REVERSING	5211A10391H	5211A10391H	5211A10391H	5211A10391H	R
552202	VALVE,REVERSING	3A02080B	3A02080B	3A02080B	3A02080B	R
552203-1	VALVE,SERVICE	5220A20006H	5220A20006H	5220A20006H	5220A20006H	R
552203-2	VALVE,SERVICE	2A00499L	2A00499L	2A00499L	2A00499L	R
554031-1	CONDENSER ASSEMBLY,BENT	5403A20193A	5403A20193A	5403A20193A	5403A20193A	R
554031-2	CONDENSER ASSEMBLY,BENT	5403A20193B	5403A20193B	5403A20193B	5403A20193B	R
554160	COMPRESSOR ASSEMBLY	5416A90026A	5416A90026A	5416A90026A	5416A90026A	R
559010	FAN ASSEMBLY,PROPELLER	1A00195B	1A00195B	1A00195B	1A00195B	R
561410	COIL ASSEMBLY,REVERSING VALVE	-	-	6141AR3733R	6141AR3733R	R
435511	COVER ASSEMBLY CONTROL	3A01293X	3A01293X	3A01293X	3A01293X	R
649950	CONTROL BOX ASSEMBLY,OUTDOOR	6615AP2772Z	L1995A10010S	4995A30011H	4995A10010L	R
263230	THERMISTOR ASSEMBLY	-	-	3Q35015H	3Q35015H	R
268712	PWB(PCB) ASSY,DEICER	-	-	6871A20034A	6871A20034A	R
669200	RELAY	-	-	3A00261C	3A00261C	R
648600	CLAMP CAPACITOR	4H00442B	4H00442B	4H00442B	4H00442B	R
W6640	TERMINAL BLOCK	3A00493A	3A00493A	3A00493A	3A00493A	R
W0CZZ	CAPACITOR,DRAWING	2A00986D	2A00986D	2A00986D	2A00986D	R
268713	PWB(PCB)ASSY, SUB	-	6871A20130K	-	6871A20130K	R

Model No.: PT-HEA/C, PT-CEA/C

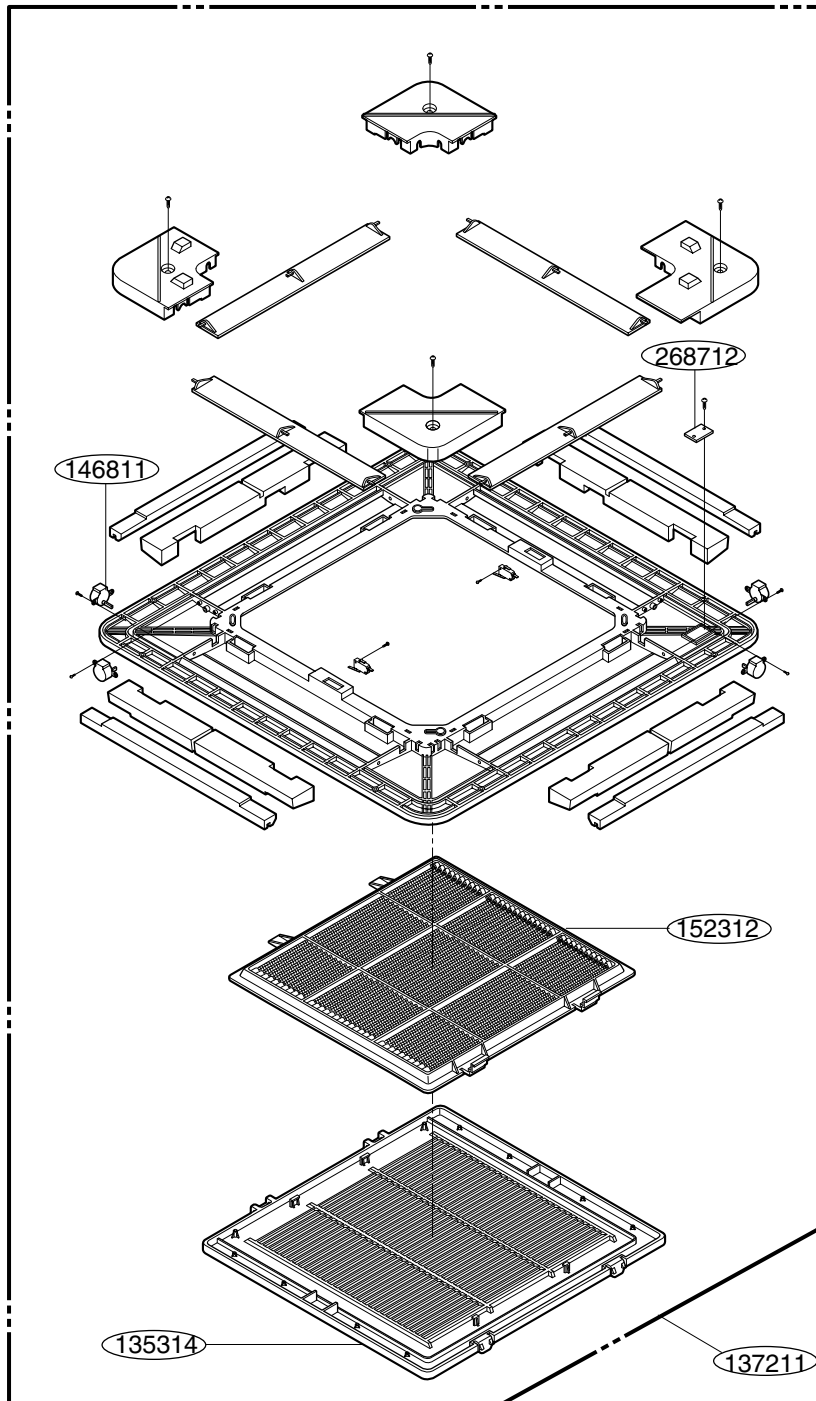

Model No.: PT-HFA/C, PT-CFA/C

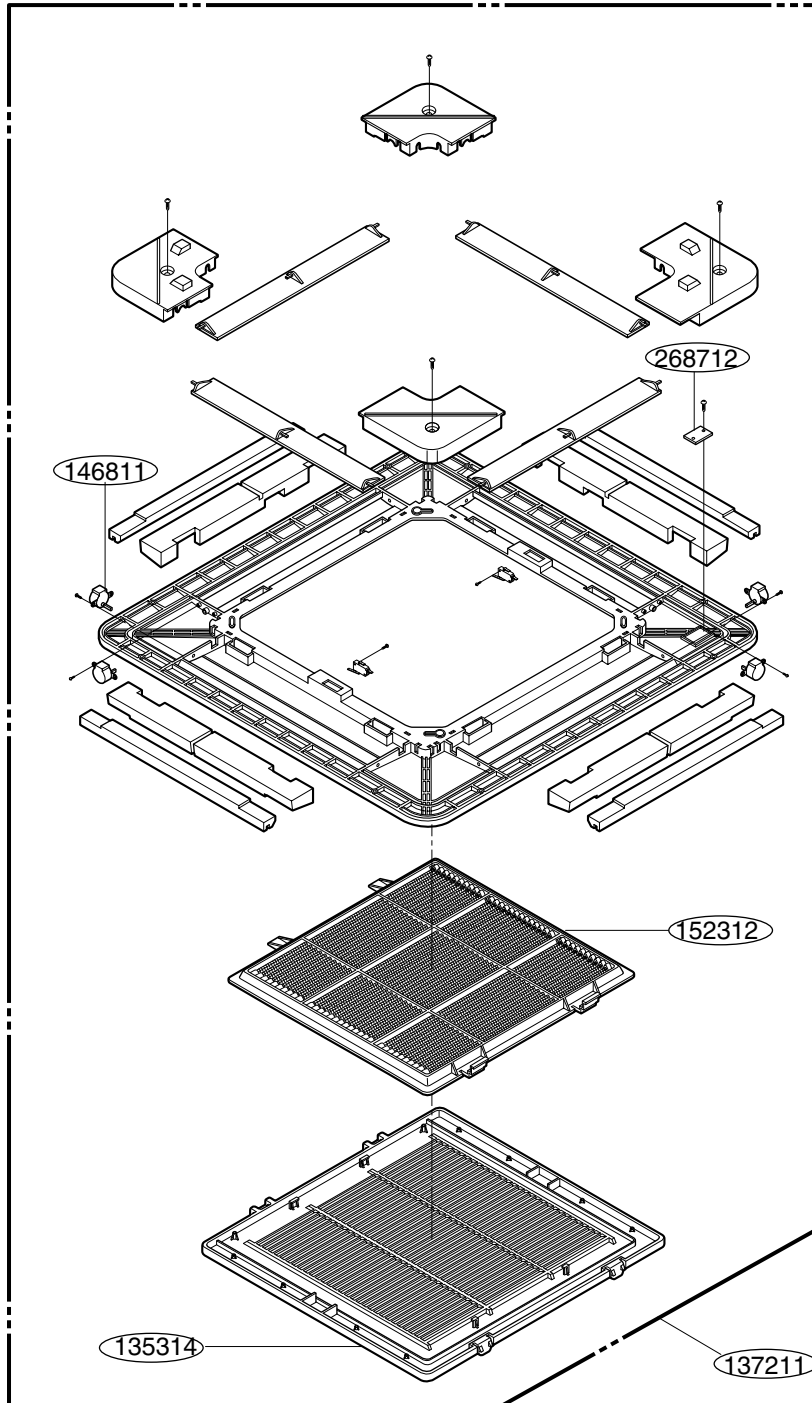

Model No.: PT-HDA/C, PT-CDA/C

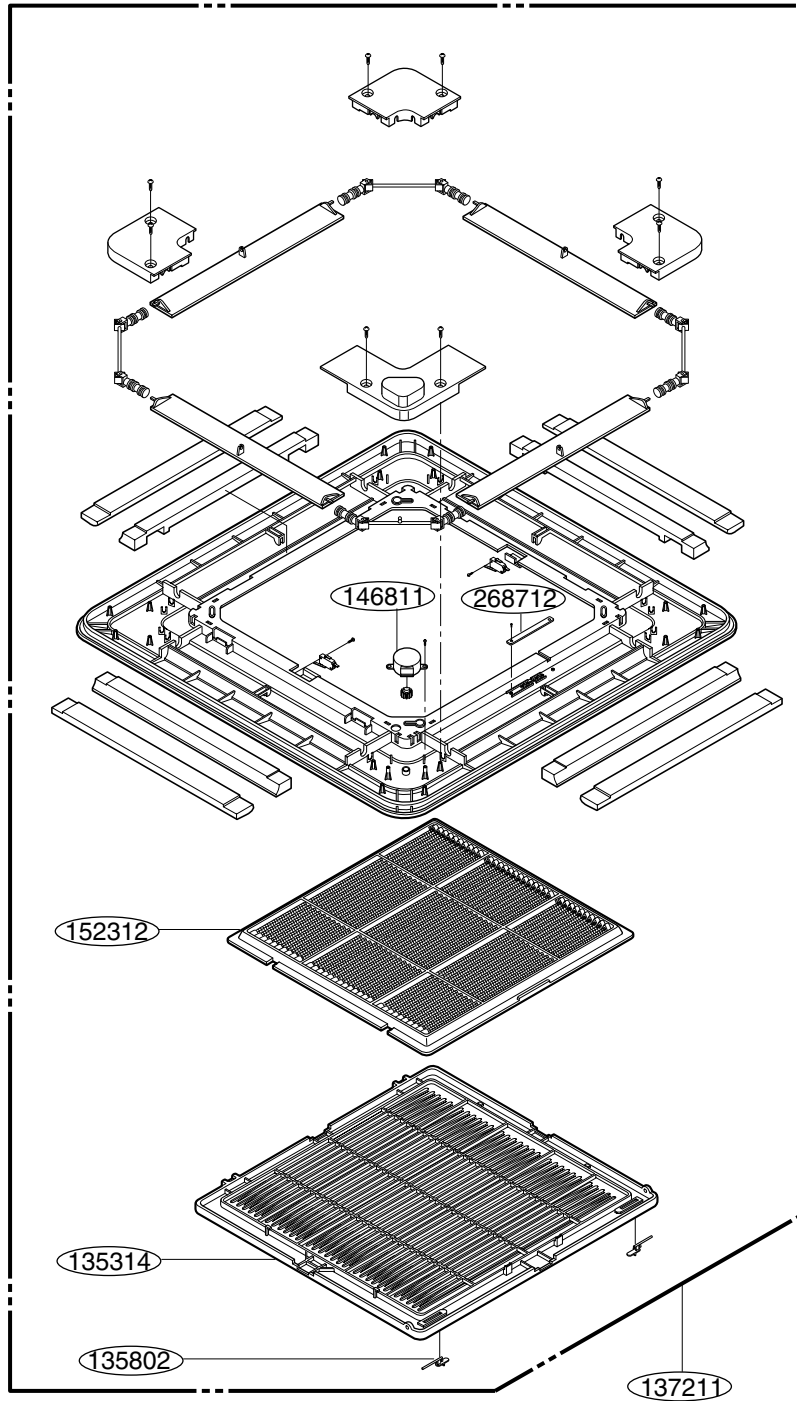

**Parts List**

LOCATION No.	DESCRIPTION	Part No.				REMARKS
		PT-CEA	PT-CEC	PT-HEA	PT-HEC	
137211	PANEL ASSEMBLY,FRONT(INDOOR)	3721A10105C	3721A10105D	3721A10105A	3721A10105B	R
135314	GRILLE ASSEMBLY,FRONT(INDOOR)	3531A10059A	3531A10059A	3531A10059A	3531A10059A	R
135312	FILTER ASSY,AIR CLEANER	5231A10005A	5231A10005A	5231A10005A	5231A10005A	R
146811	MOTOR ASSEMBLY,STEP	4681A20055A	4681A20055A	4681A20055A	4681A20055A	R
268712	PWB(PCB) ASSEMBLY,DISPLAY	6871A20096J	6871A20096J	6871A20096J	6871A20096J	R
135802	DOOR	3580A20005A	3580A20005A	3580A20005A	3580A20005A	R

LOCATION No.	DESCRIPTION	Part No.				REMARKS
		PT-CFA	PT-CFC	PT-HFA	PT-HFC	
137211	PANEL ASSEMBLY,FRONT(INDOOR)	3721A10072B	3721A10072G	3721A10072A	3721A10072E	R
135314	GRILLE ASSEMBLY,FRONT(INDOOR)	3531A10211A	3531A10211C	3531A10211A	3531A10211C	R
135312	FILTER ASSY,AIR CLEANER	5231A10012A	5231A10012A	5231A10012A	5231A10012A	R
146811	MOTOR ASSEMBLY,STEP	4681A20055A	4681A20055A	4681A20055A	4681A20055A	R
268712	PWB(PCB) ASSEMBLY,DISPLAY	6871A20096J	6871A20096J	6871A20096J	6871A20096J	R

LOCATION No.	DESCRIPTION	Part No.				REMARKS
		PT-CDA	PT-CDC	PT-HDA	PT-HDC	
137211	PANEL ASSEMBLY,FRONT(INDOOR)	3721A10106C	3721A10106D	3721A10106A	3721A10106B	R
135314	GRILLE ASSEMBLY,FRONT(INDOOR)	3531A10066A	3531A10066A	3531A10066A	3531A10066A	R
135312	FILTER ASSY,AIR CLEANER	5231A10004A	5231A10004A	5231A10004A	5231A10004A	R
146811	MOTOR ASSEMBLY,STEP	4681A20055A	4681A20055A	4681A20055A	4681A20055A	R
268712	PWB(PCB) ASSEMBLY,DISPLAY	6871A20096J	6871A20096J	6871A20096J	6871A20096J	R
135802	DOOR	3580A20005A	3580A20005A	3580A20005A	3580A20005A	R

